

6210-VO Electronic Foot Potentiometer

herga

Technology Ltd

- Provides a variable voltage output proportional to the position of the pedal
- Utilising a solid state optical sensor with no moving parts or tracks which can wear out
- Ideal for repetitive use with office equipment, domestic/medical appliances and general industrial applications
- Low cost
- Customer colours and logos available on request



Reference dimensions

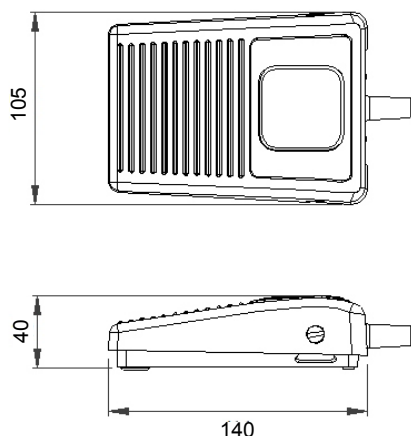

Stock model: 6210-VO

General specifications

Standards/approvals	Footswitch: low voltage directive 2014/35/EU, EN 60950
Degree of protection	EN 60529 IPX2
Connection method	3-core cable (2m long) with stripped cable cores or connector of your choice
Electrical rating	4.5V to 12V at 10mA
Output voltage range	6% minimum to 95% maximum of input voltage
Output current/type	100µA / Transistor Sink/Source

Operating temperature range	0°C to +40°C
Body material	Thermoplastic
Weight	0.35 kg
Average life expectancy	> 1 000 000 operations

6210-VO Recommended application circuit

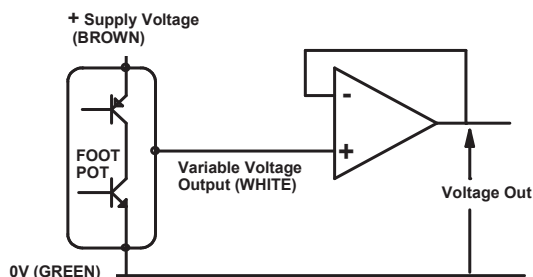

Accessories

Part Number	Description
6202-0001	Single Black RAL 9005 guard
6202-0002	Single Grey RAL 7035 guard
6202-0003	Twin Grey RAL 7035 guard

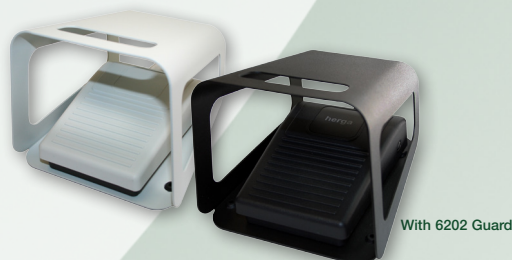

With 6202 Guard



Herga Technology Ltd - Northern Way - Bury St. Edmunds - Suffolk - IP32 6NN - UK
 sales@herga.com • www.herga.com • +44 (0)1284 701422

Subject to change without notice