

MDOB256064BX-YM	256 x 64	OLED Module
<b>Specification</b>		
Version: 1	Date: 15/10/2013	
<b>Revision</b>		
1	15/10/2013	First Issue

Display Features			Box Quantity	Weight / Display
Resolution	256 x 64			
Appearance	Yellow on Black			
Logic Voltage	3.3V			
Interface	Parallel, SPI			
Module Size	100.50 x 33.50 x 6.30mm			
Operating Temperature	-40°C ~ +85°C			
Construction	COB			

\* - For full design functionality, please use this specification in conjunction with the SSD1322 specification. (Provided Separately)

Display Accessories	
Part Number	Description

Optional Variants	
Appearance	Voltage



## 1. FUNCTIONS & FEATURES

### Features

Item	Specs
Display Mode/Colour	Passive Matrix OLED. YELLOW/WHITE/GREEN
Interface	8-Bit 68XX/80XX Parallel、SPI
Drive Duty	1/64
Driver IC	SSD1322
Shell	0.5T
Other	- 256X64 dots

## 2. MECHANICAL SPECIFICATIONS

ITEM	SPECIFICATIONS	UNIT
Module Size	100.5L×33.5W×6.3H	mm
View Area	78.78×21.18	mm
Effective Area	256×64	dots
Pixel Size	0.28×0.28	mm
Pixel Pitch	0.30×0.30	mm

## 3. EXTERNAL DIMENSIONS



# Count drawing's modified record with customer

VER.	DESCRIPTION	DATE
#1	THE FIRST ISSUE	2013-10-15

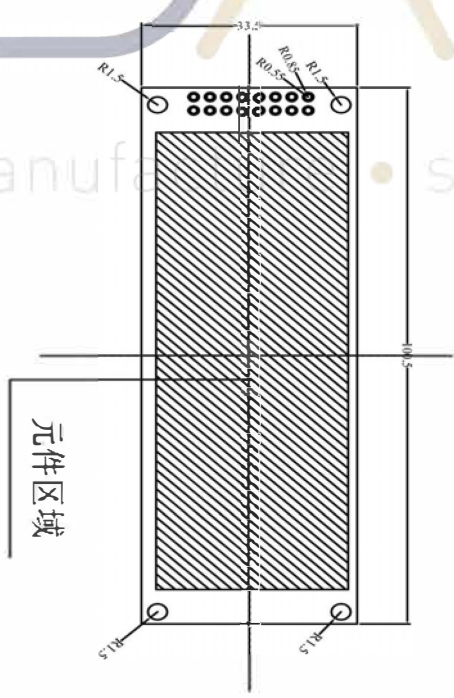
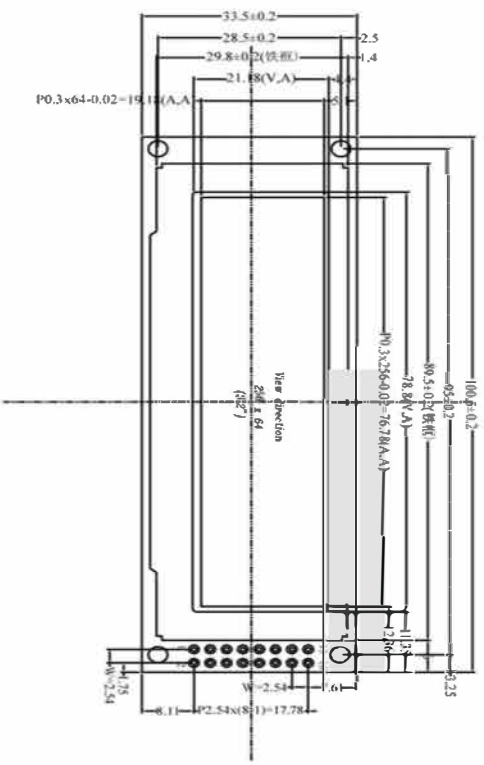

PIN ASSIGNMENT

1	Vcc
2	VBAT
3	NC
4	D90
5	DB1
6	D92
7	D93
8	D94
9	D95
10	D96
11	D97
12	/RD
13	/TR
14	DC
15	/RESST
16	/CS

Display Type	OLED
Logic IO Level	NEGATIVE TRANSMISSIVE
Operation Temperature	3.0V
Storage Temperature	-40°C TO +85°C
Interface	-45°C TO +90°C
Color	SPI and 6800/8080
Drive IC	Yellow/Blue, SSD1322
All radii without dimension	
Unspecified tolerance is	±0.2
ROHS request	Yes

UNIT	SIZE	SCALE	MODULE NO.	DESIGNED	CHECKED	VERIFIED	APPROVED	Glass No.	FILE NAME
mm	A4	1:1	MDO0B256064BX-YM	Joffery					Count Drawing

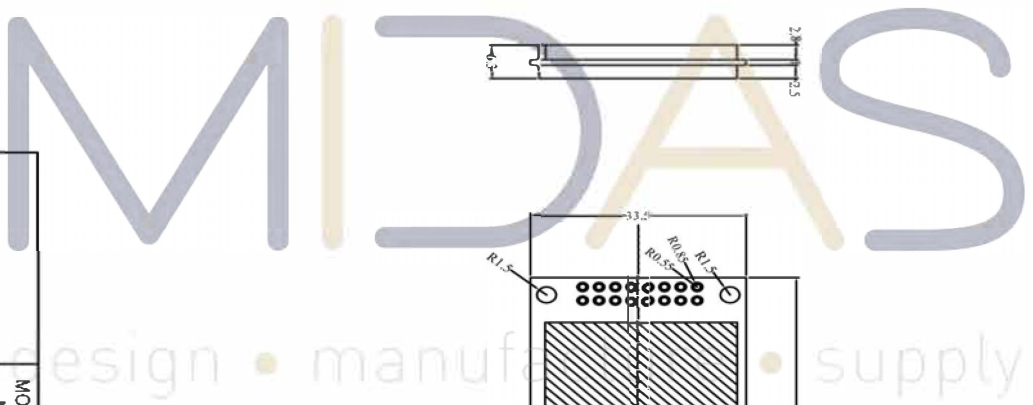

#### 4. BLOCK DIAGRAM

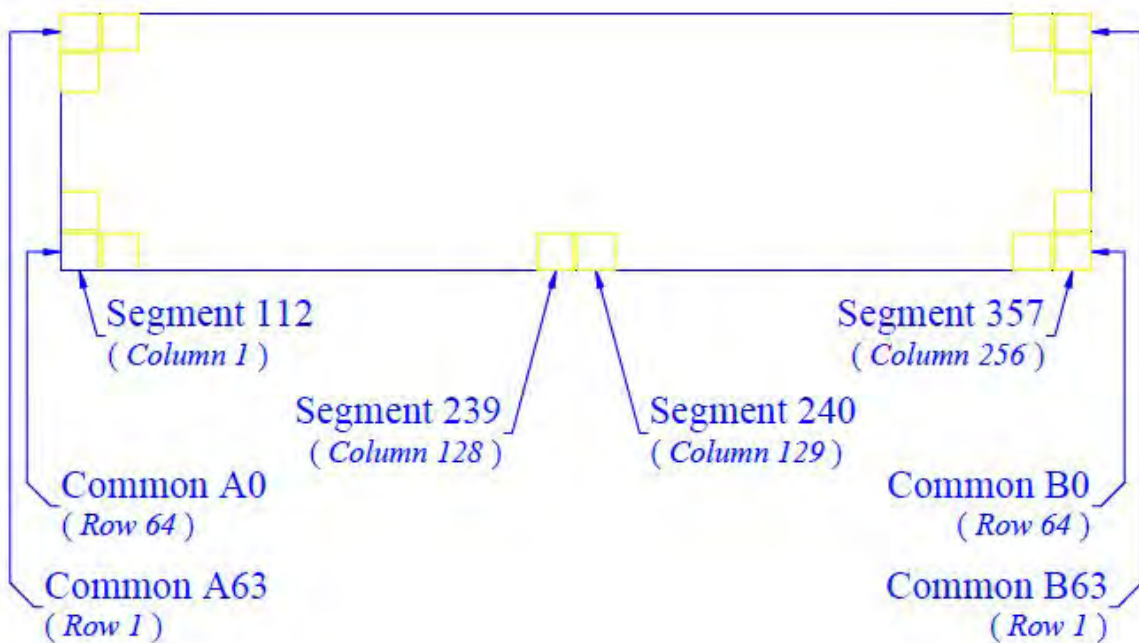
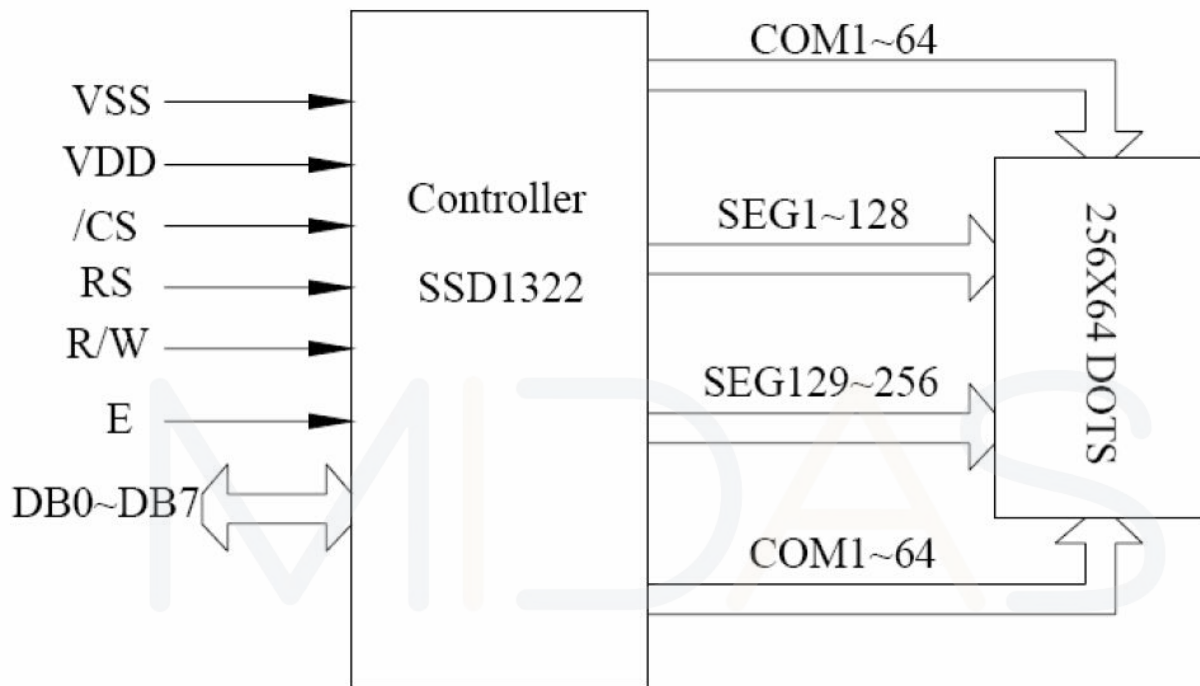

## 5. POWER SUPPLY

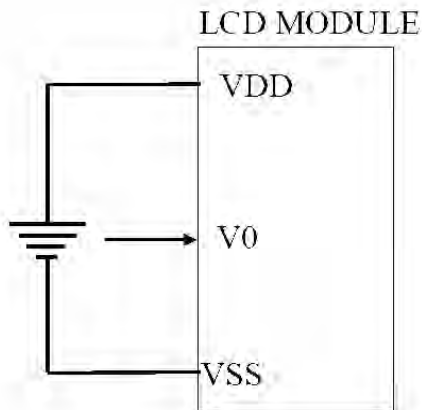

## 6. PIN DESCRIPTION

Parallel Interface(8080): (R18,R21 USE; R19,R20 NO USE)

ITEM	SYMBOL	LEVEL	FUNCTION
1	GND	0V	Power Ground
2	VDD	+3.3~+5.0V	Power Supply For Logic
3	NC	-	No connect
4~11	D0~D7	H/L	Data Bus
12	RD	H/L	8080: Active LOW Read signal
13	WR	H/L	8080:Active LOW Write signal
14	D/C(RS)	H/L	H: Data L: Command
15	/RST	H/L	Active LOW Reset signal
16	/CS	L	Chip Select

Parallel Interface(6800): (R18,R20 USE; R19,R21 NO USE)

ITEM	SYMBOL	LEVEL	FUNCTION
1	GND	0V	Power Ground
2	VDD	+3.3~+5.0V	Power Supply For Logic
3	NC	-	No connect
4~11	D0~D7	H/L	Data Bus
12	RD	H/L	6800:Operation enable signal. Falling edge triggered.
13	WR	H/L	6800:Read/Write select signal, R/W=1: Read R/W: =0: Write
14	D/C(RS)	H/L	H: Data L: Command
15	/RST	H/L	Active LOW Reset signal
16	/CS	L	Chip Select

#### 4-SPI: (R19,R21 USE; R18,R20 NO USE)

ITEM	SYMBOL	LEVEL	FUNCTION
1	GND	0V	Power Ground
2	VDD	+3.3~+5.0V	Power Supply For Logic
3	NC	-	No connect
4	SCLK(D0)	H/L	Serial Clock signal
5	SDIN(D1)	H/L	Serial Data input signal
6	NC(D2)	-	No connect
7~11	D3~D7	0V	Power Ground
12	RD	0V	Power Ground
13	WR	0V	Power Ground
14	D/C(RS)	H/L	H: Data L: Command
15	/RST	H/L	Active LOW Reset signal
16	/CS	L	Chip Select

#### 3-SPI : (R19,R20 USE; R18,R21 NO USE)

ITEM	SYMBOL	LEVEL	FUNCTION
1	GND	0V	Power Ground
2	VDD	+3.3~+5.0V	Power Supply For Logic
3	NC	-	No connect
4	SCLK(D0)	H/L	Serial Clock signal
5	SDIN(D1)	H/L	Serial Data input signal
6	NC(D2)	-	No connect
7~11	D3~D7	0V	Power Ground
12	RD	0V	Power Ground
13	WR	0V	Power Ground
14	D/C(RS)	0V	Power Ground
15	/RST	H/L	Active LOW Reset signal
16	/CS	L	Chip Select

MCU Interface assignment under different bus interface mode:

Pin Name Bus Interface	Data/Command Interface								Control Signal				
	D7	D6	D5	D4	D3	D2	D1	D0	E	R/W#	CS#	D/C#	RES#
8-bit 8080	D[7:0]								RD#	WR#	CS#	D/C#	RES#
8-bit 6800	D[7:0]								E	R/W#	CS#	D/C#	RES#
3-wire SPI	Tie LOW					NC	SDIN	SCLK	Tie LOW	CS#	Tie LOW	RES#	
4-wire SPI	Tie LOW					NC	SDIN	SCLK	Tie LOW	CS#	D/C#	RES#	

## 7. Absolute Maximum Ratings

Parameter	Symbol	Min	Max	Unit	Notes
Supply Voltage for Logic	V <sub>dd</sub>	3.3	5	V	1, 2
Supply Voltage for Display	V <sub>cc</sub>	0	15	V	1, 2
Operating Temperature	T <sub>op</sub>	-40	85	°C	-
Storage Temperature	T <sub>st</sub>	-45	90	°C	-

Note 1: All the above voltages are on the basis of “VSS = 0V”.

Note 2: When this module is used beyond the above absolute maximum ratings, permanent breakage of the module may occur. Also, for normal operations, it is desirable to use this module under the conditions according to Section 3. “Optics & Electrical Characteristics”. If this module is used beyond these conditions, malfunctioning of the module can occur and the reliability of the module may deteriorate.

## 8. ELECTRICAL CHARACTERISTICS

Items	Symbol	Condition	Min	TY P	Max	Unit
Operating Temperature Range	T <sub>op</sub>	Absolute Max	-40	—	+85	C
Storage Temperature Range	T <sub>st</sub>	Absolute Max	-45	—	+90	C
Supply Voltage	V <sub>dd</sub>		2.8	3.0	3.3	V
Supply Current (logic)	I <sub>dd</sub>	T <sub>a</sub> =25°C, V <sub>DD</sub> =3.3V	—	180	300	μA
Supply Current (display)	I <sub>CC</sub>	50% ON, V <sub>DD</sub> =3.3V	—	62	70	mA
		100% ON, V <sub>DD</sub> =3.3V	—	113	120	mA
Sleep Mode Current	I <sub>DD</sub> +I <sub>CCS</sub> LEEP		—	3	15	μA
“H” Level input	V <sub>ih</sub>		0.8*V <sub>DD</sub>	—	V <sub>DD</sub>	V
“L” Level input	V <sub>il</sub>		V <sub>SS</sub>	—	0.2*V <sub>DD</sub>	V
“H” Level output	V <sub>oh</sub>		0.9*V <sub>DD</sub>	—	V <sub>DD</sub>	V
“L” Level output	V <sub>ol</sub>		V <sub>SS</sub>	—	0.1*V <sub>DD</sub>	V

## 9. Optical Characteristics

Item	Symbol	Condition	Min.	Typ.	Max.	Unit
Viewing Angle – Top	AV		—	80	—	
Viewing Angle – Bottom	AV		—	80	—	
Viewing Angle – Left	AH		—	80	—	
Viewing Angle – Right	AH		—	80	—	

Contrast Ratio	Cr		2000:1	—	—	—
Response Time (rise)	Tr	—	—	10	—	us
Response Time (fall)	Tf	—	—	10	—	us
Brightness		50% checkerboard	100	120	—	cd/m2
Lifetime		Ta=25°C, 50% checkerboard	10,000	—	—	Hrs

Note: Lifetime at typical temperature is based on accelerated high - temperature operation. Lifetime is tested at average 50% pixels on and is rated as Hours until Half - Brightness. The Display OFF command can be used to extend the lifetime of the display.

Luminance of active pixels will degrade faster than inactive pixels. Residual (burn - in) images may occur. To avoid this, every pixel should be illuminated uniformly.

# MIDAS

design • manufacture • supply





## 10. COMMAND TABLE

Built - in SSD1322 controller.

D/C#	Hex	D7	D6	D5	D4	D3	D2	D2	D0	Command	Description
0	00	0	0	0	0	0	0	0	0	Enable Gray Scale table	This command is sent to enable the Gray Scale table setting (command B8h)
0 1 1	15 A[6:0] B[6:0]	0 * *	A <sub>6</sub> A <sub>6</sub> B <sub>6</sub>	A <sub>5</sub> A <sub>5</sub> B <sub>5</sub>	A <sub>4</sub> A <sub>4</sub> B <sub>4</sub>	A <sub>3</sub> A <sub>3</sub> B <sub>3</sub>	A <sub>2</sub> A <sub>2</sub> B <sub>2</sub>	A <sub>1</sub> A <sub>1</sub> B <sub>1</sub>	A <sub>0</sub> A <sub>0</sub> B <sub>0</sub>	Set Column Address	Set Column start and end address A[6:0]: Start Address. [reset=0] B[6:0]: End Address. [reset=119] Range from 0 to 119
0	5C	0	1	0	1	1	1	0	0	Write RAM Command	Enable MCU to write Data into RAM
0	5D	0	1	0	1	1	1	0	1	Read RAM Command	Enable MCU to read Data from RAM
0 1 1	75 A[6:0] B[6:0]	0 * *	A <sub>6</sub> A <sub>6</sub> B <sub>6</sub>	A <sub>5</sub> A <sub>5</sub> B <sub>5</sub>	A <sub>4</sub> A <sub>4</sub> B <sub>4</sub>	A <sub>3</sub> A <sub>3</sub> B <sub>3</sub>	A <sub>2</sub> A <sub>2</sub> B <sub>2</sub>	A <sub>1</sub> A <sub>1</sub> B <sub>1</sub>	A <sub>0</sub> A <sub>0</sub> B <sub>0</sub>	Set Row Address	Set Row start and end address A[6:0]: Start Address. [reset=0] B[6:0]: End Address. [reset=127] Range from 0 to 127
0 1 1	A0 A[7:0] B[4]	1 0 *	0 0 *	1 A <sub>5</sub> 0	0 A <sub>4</sub> B <sub>4</sub>	0 0 0	0 A <sub>2</sub> 0	0 A <sub>1</sub> 0	0 A <sub>0</sub> 1	Set Re-map and Dual COM Line mode	A[0]=0b, Horizontal address increment [reset] A[0]=1b, Vertical address increment  A[1]=0b, Disable Column Address Re-map [reset] A[1]=1b, Enable Column Address Re-map  A[2]=0b, Disable Nibble Re-map [reset] A[2]=1b, Enable Nibble Re-map  A[4]=0b, Scan from COM0 to COM[N-1] [reset] A[4]=1b, Scan from COM[N-1] to COM0, where N is the Multiplex ratio  A[5]=0b, Disable COM Split Odd Even [reset] A[5]=1b, Enable COM Split Odd Even  B[4], Enable / disable Dual COM Line mode 0b, Disable Dual COM mode [reset] 1b, Enable Dual COM mode (MUX ≤ 63)  <b>Note</b> <sup>(1)</sup> COM Split Odd Even mode must be disabled (A[5]=0b) when enabling the Dual COM mode (B[4]=1b)  Details refer to Section 10.1.6
0 1	A1 A[6:0]	1 *	0 A <sub>6</sub>	1 A <sub>5</sub>	0 A <sub>4</sub>	0 A <sub>3</sub>	0 A <sub>2</sub>	0 A <sub>1</sub>	1 A <sub>0</sub>	Set Display Start Line	Set display RAM display start line register from 0-127 Display start line register is reset to 00h after RESET

D/C#	Hex	D7	D6	D5	D4	D3	D2	D2	D0	Command	Description																																		
0 1	A2 A[6:0]	1 *	0 A <sub>6</sub>	1 A <sub>5</sub>	0 A <sub>4</sub>	0 A <sub>3</sub>	0 A <sub>2</sub>	1 A <sub>1</sub>	0 A <sub>0</sub>	Set Display Offset	Set vertical scroll by COM from 0-127 The value is reset to 00H after RESET																																		
0	A4~A7	1	0	1	0	0	X <sub>2</sub>	X <sub>1</sub>	X <sub>0</sub>	Set Display Mode	A4h = Entire Display OFF, all pixels turns OFF in GS level 0 A5h = Entire Display ON, all pixels turns ON in GS level 15 A6h = Normal Display [reset] A7h = Inverse Display (GS0 → GS15, GS1 → GS14, GS2 → GS13, ...)																																		
0 1 1	A8 A[6:0] B[6:0]	1 0 0	0 A <sub>6</sub> B <sub>6</sub>	1 A <sub>5</sub> B <sub>5</sub>	0 A <sub>4</sub> B <sub>4</sub>	1 A <sub>3</sub> B <sub>3</sub>	0 A <sub>2</sub> B <sub>2</sub>	0 A <sub>1</sub> B <sub>1</sub>	0 A <sub>0</sub> B <sub>0</sub>	Enable Partial Display	This command turns ON partial mode. The partial mode display area is defined by the following two parameters, A[6:0]: Address of start row in the display area B[6:0]: Address of end row in the display area, where B[6:0] must be ≥ A[6:0]																																		
0	A9	1	0	1	0	1	0	0	1	Exit Partial Display	This command is sent to exit the Partial Display mode																																		
0 1	AB A[0]	1 0	0 0	1 0	0 0	1 0	0 0	1 0	1 A <sub>0</sub>	Function Selection	A[0]=0b, Select external V <sub>DD</sub> A[0]=1b, Enable internal V <sub>DD</sub> regulator [reset]																																		
0	AE~AF	1	0	1	0	1	1	1	X <sub>0</sub>	Set Sleep mode ON/OFF	AEh = Sleep mode ON (Display OFF) AFh = Sleep mode OFF (Display ON)																																		
0 1	B1 A[7:0]	1 A <sub>7</sub>	0 A <sub>6</sub>	1 A <sub>5</sub>	1 A <sub>4</sub>	0 A <sub>3</sub>	0 A <sub>2</sub>	0 A <sub>1</sub>	1 A <sub>0</sub>	Set Phase Length	A[3:0] Phase 1 period (reset phase length) of 5~31 DCLK(s) clocks as follow: <table border="1" data-bbox="962 1182 1286 1391"> <thead> <tr> <th>A[3:0]</th> <th>Phase 1 period</th> </tr> </thead> <tbody> <tr><td>0000</td><td>invalid</td></tr> <tr><td>0001</td><td>invalid</td></tr> <tr><td>0010</td><td>5 DCLKs</td></tr> <tr><td>0011</td><td>7 DCLKs</td></tr> <tr><td>0100</td><td>9 DCLKs [reset]</td></tr> <tr><td>:</td><td>:</td></tr> <tr><td>1111</td><td>31 DCLKs</td></tr> </tbody> </table> A[7:4] Phase 2 period (first pre-charge phase length) of 3~15 DCLK(s) clocks as follow: <table border="1" data-bbox="967 1514 1281 1744"> <thead> <tr> <th>A[7:4]</th> <th>Phase 2 period</th> </tr> </thead> <tbody> <tr><td>0000</td><td>invalid</td></tr> <tr><td>0001</td><td>invalid</td></tr> <tr><td>0010</td><td>invalid</td></tr> <tr><td>0011</td><td>3 DCLKs</td></tr> <tr><td>:</td><td>:</td></tr> <tr><td>0111</td><td>7 DCLKs [reset]</td></tr> <tr><td>:</td><td>:</td></tr> <tr><td>1111</td><td>15 DCLKs</td></tr> </tbody> </table>	A[3:0]	Phase 1 period	0000	invalid	0001	invalid	0010	5 DCLKs	0011	7 DCLKs	0100	9 DCLKs [reset]	:	:	1111	31 DCLKs	A[7:4]	Phase 2 period	0000	invalid	0001	invalid	0010	invalid	0011	3 DCLKs	:	:	0111	7 DCLKs [reset]	:	:	1111	15 DCLKs
A[3:0]	Phase 1 period																																												
0000	invalid																																												
0001	invalid																																												
0010	5 DCLKs																																												
0011	7 DCLKs																																												
0100	9 DCLKs [reset]																																												
:	:																																												
1111	31 DCLKs																																												
A[7:4]	Phase 2 period																																												
0000	invalid																																												
0001	invalid																																												
0010	invalid																																												
0011	3 DCLKs																																												
:	:																																												
0111	7 DCLKs [reset]																																												
:	:																																												
1111	15 DCLKs																																												



D/C#	Hex	D7	D6	D5	D4	D3	D2	D2	D0	Command	Description																										
0 1	B3 A[7:0]	1 A <sub>7</sub>	0 A <sub>6</sub>	1 A <sub>5</sub>	1 A <sub>4</sub>	0 A <sub>3</sub>	0 A <sub>2</sub>	1 A <sub>1</sub>	1 A <sub>0</sub>	Set Front Clock Divider / Oscillator Frequency	<p>A[3:0] [reset=0], divide by DIVSET where</p> <table border="1"> <thead> <tr> <th>A[3:0]</th> <th>DIVSET</th> </tr> </thead> <tbody> <tr><td>0000</td><td>divide by 1</td></tr> <tr><td>0001</td><td>divide by 2</td></tr> <tr><td>0010</td><td>divide by 4</td></tr> <tr><td>0011</td><td>divide by 8</td></tr> <tr><td>0100</td><td>divide by 16</td></tr> <tr><td>0101</td><td>divide by 32</td></tr> <tr><td>0110</td><td>divide by 64</td></tr> <tr><td>0111</td><td>divide by 128</td></tr> <tr><td>1000</td><td>divide by 256</td></tr> <tr><td>1001</td><td>divide by 512</td></tr> <tr><td>1010</td><td>divide by 1024</td></tr> <tr><td>&gt;=1011</td><td>invalid</td></tr> </tbody> </table> <p>A[7:4] Oscillator frequency, frequency increases as level increases [reset=0101b]</p>	A[3:0]	DIVSET	0000	divide by 1	0001	divide by 2	0010	divide by 4	0011	divide by 8	0100	divide by 16	0101	divide by 32	0110	divide by 64	0111	divide by 128	1000	divide by 256	1001	divide by 512	1010	divide by 1024	>=1011	invalid
A[3:0]	DIVSET																																				
0000	divide by 1																																				
0001	divide by 2																																				
0010	divide by 4																																				
0011	divide by 8																																				
0100	divide by 16																																				
0101	divide by 32																																				
0110	divide by 64																																				
0111	divide by 128																																				
1000	divide by 256																																				
1001	divide by 512																																				
1010	divide by 1024																																				
>=1011	invalid																																				
0 1 1	B4 A[1:0] B[7:3]	1 1 B <sub>7</sub>	0 0 B <sub>6</sub>	1 1 B <sub>5</sub>	1 0 B <sub>4</sub>	0 0 B <sub>3</sub>	1 0 1	0 A <sub>1</sub> 0	0 A <sub>0</sub> 1	Display Enhancement A	<p>A[1:0] = 00b: Enable external VSL A[1:0] = 10b: Internal VSL [reset]</p> <p>B[7:3] = 11111b: Enhanced low GS display quality B[7:3] = 10110b: Normal [reset]</p>																										
0 1	B5 A[3:0]	1 *	0 *	1 *	1 *	0 A <sub>3</sub>	1 A <sub>2</sub>	0 A <sub>1</sub>	1 A <sub>0</sub>	Set GPIO	<p>A[1:0] GPIO0: 00 pin HiZ, Input disabled 01 pin HiZ, Input enabled 10 pin output LOW [reset] 11 pin output HIGH</p> <p>A[3:2] GPIO1: 00 pin HiZ, Input disabled 01 pin HiZ, Input enabled 10 pin output LOW [reset] 11 pin output HIGH</p>																										
0 1	B6 A[3:0]	1 *	0 *	1 *	1 *	0 A <sub>3</sub>	1 A <sub>2</sub>	1 A <sub>1</sub>	0 A <sub>0</sub>	Set Second Precharge Period	<p>A[3:0] Second Pre-charge period</p> <p>0000b 0 dclk 0001b 1 dclk ..... 1000b 8 dclks [reset] ..... 1111b 15 dclks</p>																										



D/C#	Hex	D7	D6	D5	D4	D3	D2	D2	D0	Command	Description																		
0	B8	1	0	1	1	1	0	0	0		<p>The next 15 data bytes define Gray Scale (GS) Table by setting the gray scale pulse width in unit of DCLK's (ranges from 0d ~ 180d)</p> <p><b>Set Gray Scale Table</b></p> <p>A1[7:0]: Gamma Setting for GS1,  A2[7:0]: Gamma Setting for GS2,  :  A14[7:0]: Gamma Setting for GS14,  A15[7:0]: Gamma Setting for GS15</p> <p><b>Note</b>  <sup>(1)</sup> 0 ≤ Setting of GS1 &lt; Setting of GS2 &lt; Setting of GS3..... &lt; Setting of GS14 &lt; Setting of GS15</p> <p>Refer to Section 8.8 for details</p> <p><sup>(2)</sup> The setting must be followed by the Enable Gray Scale Table command (00h)</p>																		
1	A1[7:0]	A1 <sub>7</sub>	A1 <sub>6</sub>	A1 <sub>5</sub>	A1 <sub>4</sub>	A1 <sub>3</sub>	A1 <sub>2</sub>	A1 <sub>1</sub>	A1 <sub>0</sub>																				
1	A2[7:0]	A2 <sub>7</sub>	A2 <sub>6</sub>	A2 <sub>5</sub>	A2 <sub>4</sub>	A2 <sub>3</sub>	A2 <sub>2</sub>	A2 <sub>1</sub>	A2 <sub>0</sub>																				
1	.	.	.	.	.	.	.	.	.																				
1	.	.	.	.	.	.	.	.	.																				
1	.	.	.	.	.	.	.	.	.																				
1	A14[7:0]	A14 <sub>7</sub>	A14 <sub>6</sub>	A14 <sub>5</sub>	A14 <sub>4</sub>	A14 <sub>3</sub>	A14 <sub>2</sub>	A14 <sub>1</sub>	A14 <sub>0</sub>																				
1	A15[7:0]	A15 <sub>7</sub>	A15 <sub>6</sub>	A15 <sub>5</sub>	A15 <sub>4</sub>	A15 <sub>3</sub>	A15 <sub>2</sub>	A15 <sub>1</sub>	A15 <sub>0</sub>																				
0	B9	1	0	1	1	1	0	0	1		<p>The default Linear Gray Scale table is set in unit of DCLK's as follow</p> <p>GS0 level pulse width = 0;  GS1 level pulse width = 0;  GS2 level pulse width = 8;  GS3 level pulse width = 16;  :  :  GS14 level pulse width = 104;  GS15 level pulse width = 112</p> <p>Refer to Section 8.8 for details</p>																		
										<p><b>Select Default Linear Gray Scale table</b></p>																			
0	BB	1	0	1	1	1	0	1	1		<p>Set pre-charge voltage level.[reset = 17h]</p> <table border="1"> <thead> <tr> <th>A[4:0]</th> <th>Hex code</th> <th>pre-charge voltage</th> </tr> </thead> <tbody> <tr> <td>00000</td> <td>00h</td> <td>0.20 x V<sub>CC</sub></td> </tr> <tr> <td>:</td> <td>:</td> <td>:</td> </tr> <tr> <td>11111</td> <td>1Fh</td> <td>0.60 x V<sub>CC</sub></td> </tr> </tbody> </table>	A[4:0]	Hex code	pre-charge voltage	00000	00h	0.20 x V <sub>CC</sub>	:	:	:	11111	1Fh	0.60 x V <sub>CC</sub>						
A[4:0]	Hex code	pre-charge voltage																											
00000	00h	0.20 x V <sub>CC</sub>																											
:	:	:																											
11111	1Fh	0.60 x V <sub>CC</sub>																											
1	A[4:0]	*	*	*	A <sub>4</sub>	A <sub>3</sub>	A <sub>2</sub>	A <sub>1</sub>	A <sub>0</sub>	<p><b>Set Pre-charge voltage</b></p>																			
0	BE	1	0	1	1	1	1	1	0		<p>Set COM deselect voltage level [reset = 04h]</p> <table border="1"> <thead> <tr> <th>A[2:0]</th> <th>Hex code</th> <th>V<sub>COMH</sub></th> </tr> </thead> <tbody> <tr> <td>000</td> <td>00h</td> <td>0.72 x V<sub>CC</sub></td> </tr> <tr> <td>:</td> <td>:</td> <td>:</td> </tr> <tr> <td>100</td> <td>04h</td> <td>0.80 x V<sub>CC</sub> [reset]</td> </tr> <tr> <td>:</td> <td>:</td> <td>:</td> </tr> <tr> <td>111</td> <td>07h</td> <td>0.86 x V<sub>CC</sub></td> </tr> </tbody> </table>	A[2:0]	Hex code	V <sub>COMH</sub>	000	00h	0.72 x V <sub>CC</sub>	:	:	:	100	04h	0.80 x V <sub>CC</sub> [reset]	:	:	:	111	07h	0.86 x V <sub>CC</sub>
A[2:0]	Hex code	V <sub>COMH</sub>																											
000	00h	0.72 x V <sub>CC</sub>																											
:	:	:																											
100	04h	0.80 x V <sub>CC</sub> [reset]																											
:	:	:																											
111	07h	0.86 x V <sub>CC</sub>																											
1	A[2:0]	*	*	*	*	0	A <sub>2</sub>	A <sub>1</sub>	A <sub>0</sub>	<p><b>Set V<sub>COMH</sub></b></p>																			
0	C1	1	1	0	0	0	0	0	1		<p><b>Set Contrast Current</b></p> <p>A[7:0]: Contrast current value, range:00h~FFh, i.e. 256 steps for I<sub>SEG</sub> current [reset = 7Fh]</p>																		
1	A[7:0]	A <sub>7</sub>	A <sub>6</sub>	A <sub>5</sub>	A <sub>4</sub>	A <sub>3</sub>	A <sub>2</sub>	A <sub>1</sub>	A <sub>0</sub>																				

D/C#	Hex	D7	D6	D5	D4	D3	D2	D2	D0	Command	Description
0 1	C7 A[3:0]	1 *	1 *	0 *	0 *	0 A <sub>3</sub>	1 A <sub>2</sub>	1 A <sub>1</sub>	1 A <sub>0</sub>	Master Contrast Current Control	A[3:0] = 0000b, reduce output currents for all colors to 1/16 0001b, reduce output currents for all colors to 2/16 : 1110b, reduce output currents for all colors to 15/16 1111b, no change [reset]
0 1	CA A[6:0]	1 *	1 A <sub>6</sub>	0 A <sub>5</sub>	0 A <sub>4</sub>	1 A <sub>3</sub>	0 A <sub>2</sub>	1 A <sub>1</sub>	0 A <sub>0</sub>	Set MUX Ratio	A[6:0]: Set MUX ratio from 16MUX ~ 128MUX A[6:0] = 15d represents 16MUX : A[6:0] = 127d represents 128MUX [reset]
0 1 1	D1 A[5:4] 20	1 1 0	1 0 0	0 A <sub>5</sub> 1	1 A <sub>4</sub> 0	0 0 0	0 0 0	0 1 0	1 0 0	Display Enhancement B	A[5:4] = 00b: Reserved A[5:4] = 10b: Normal [reset]
0 1	FD A[2]	1 0	1 0	1 0	1 1	1 0	1 A <sub>2</sub>	0 1	1 0	Set Command Lock	A[2]: MCU protection status [reset = 12h] A[2] = 0b, Unlock OLED driver IC MCU interface from entering command [reset] A[2] = 1b, Lock OLED driver IC MCU interface from entering command <b>Note</b> (1) The locked OLED driver IC MCU interface prohibits all commands and memory access except the FDh command

**Note**

(1) “\*\*” stands for “Don’t care”.

For detailed instruction information, see SSD1322 datasheet.

**11 . MPU Interface**

design • manufacture • supply

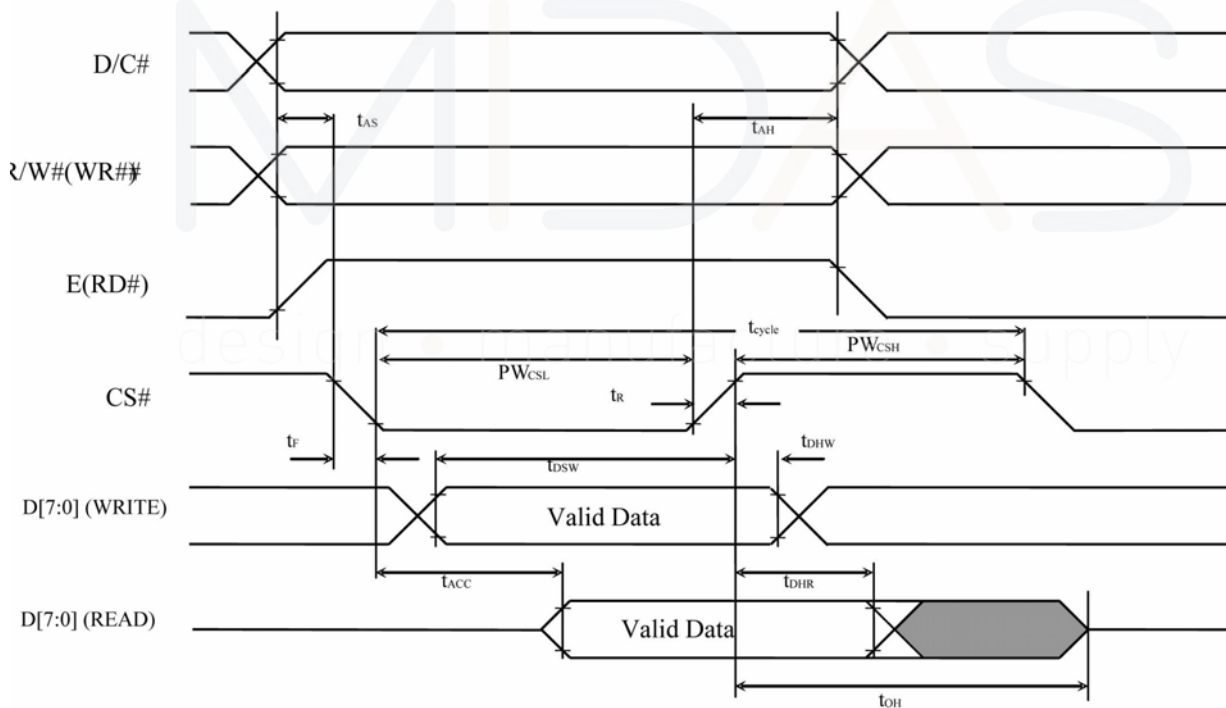

**Table 13-2 : 6800-Series MCU Parallel Interface Timing Characteristics**

( $V_{DD} - V_{SS} = 2.4$  to  $2.6V$ ,  $V_{DDIO} = 1.6V$ ,  $V_{CI} = 3.3V$ ,  $T_A = 25^\circ C$ )

Symbol	Parameter	Min	Typ	Max	Unit
$t_{cycle}$	Clock Cycle Time	300	-	-	ns
$t_{AS}$	Address Setup Time	10	-	-	ns
$t_{AH}$	Address Hold Time	0	-	-	ns
$t_{DSW}$	Write Data Setup Time	40	-	-	ns
$t_{DHW}$	Write Data Hold Time	7	-	-	ns
$t_{DHR}$	Read Data Hold Time	20	-	-	ns
$t_{OH}$	Output Disable Time	-	-	70	ns
$t_{ACC}$	Access Time	-	-	140	ns
$PW_{CSL}$	Chip Select Low Pulse Width (read)	120	-	-	ns
	Chip Select Low Pulse Width (write)	60	-	-	ns
$PW_{CSH}$	Chip Select High Pulse Width (read)	60	-	-	ns
	Chip Select High Pulse Width (write)	60	-	-	ns
$t_R$	Rise Time	-	-	15	ns
$t_F$	Fall Time	-	-	15	ns

**Figure 13-1 : 6800-series MCU parallel interface characteristics**

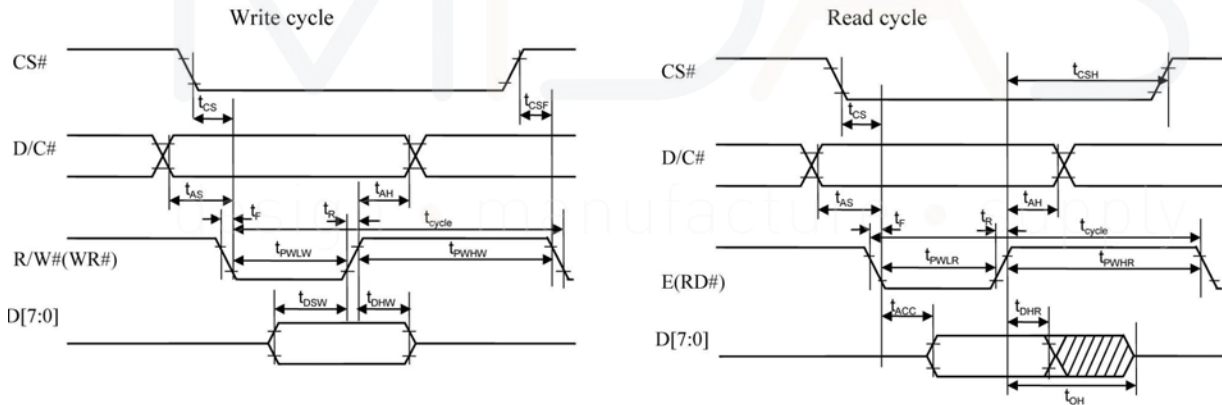

**Table 13-3 : 8080-Series MCU Parallel Interface Timing Characteristics**

( $V_{DD} - V_{SS} = 2.4$  to  $2.6V$ ,  $V_{DDIO} = 1.6V$ ,  $V_{CI} = 3.3V$ ,  $T_A = 25^\circ C$ )

Symbol	Parameter	Min	Typ	Max	Unit
$t_{cycle}$	Clock Cycle Time	300	-	-	ns
$t_{AS}$	Address Setup Time	10	-	-	ns
$t_{AH}$	Address Hold Time	0	-	-	ns
$t_{DSW}$	Write Data Setup Time	40	-	-	ns
$t_{DHW}$	Write Data Hold Time	7	-	-	ns
$t_{DHR}$	Read Data Hold Time	20	-	-	ns
$t_{OH}$	Output Disable Time	-	-	70	ns
$t_{ACC}$	Access Time	-	-	140	ns
$t_{PWL R}$	Read Low Time	150	-	-	ns
$t_{PWL W}$	Write Low Time	60	-	-	ns
$t_{PWH R}$	Read High Time	60	-	-	ns
$t_{PWH W}$	Write High Time	60	-	-	ns
$t_R$	Rise Time	-	-	15	ns
$t_F$	Fall Time	-	-	15	ns
$t_{CS}$	Chip select setup time	0	-	-	ns
$t_{CSH}$	Chip select hold time to read signal	0	-	-	ns
$t_{CSF}$	Chip select hold time	20	-	-	ns

**Figure 13-2 : 8080-series MCU parallel interface characteristics**

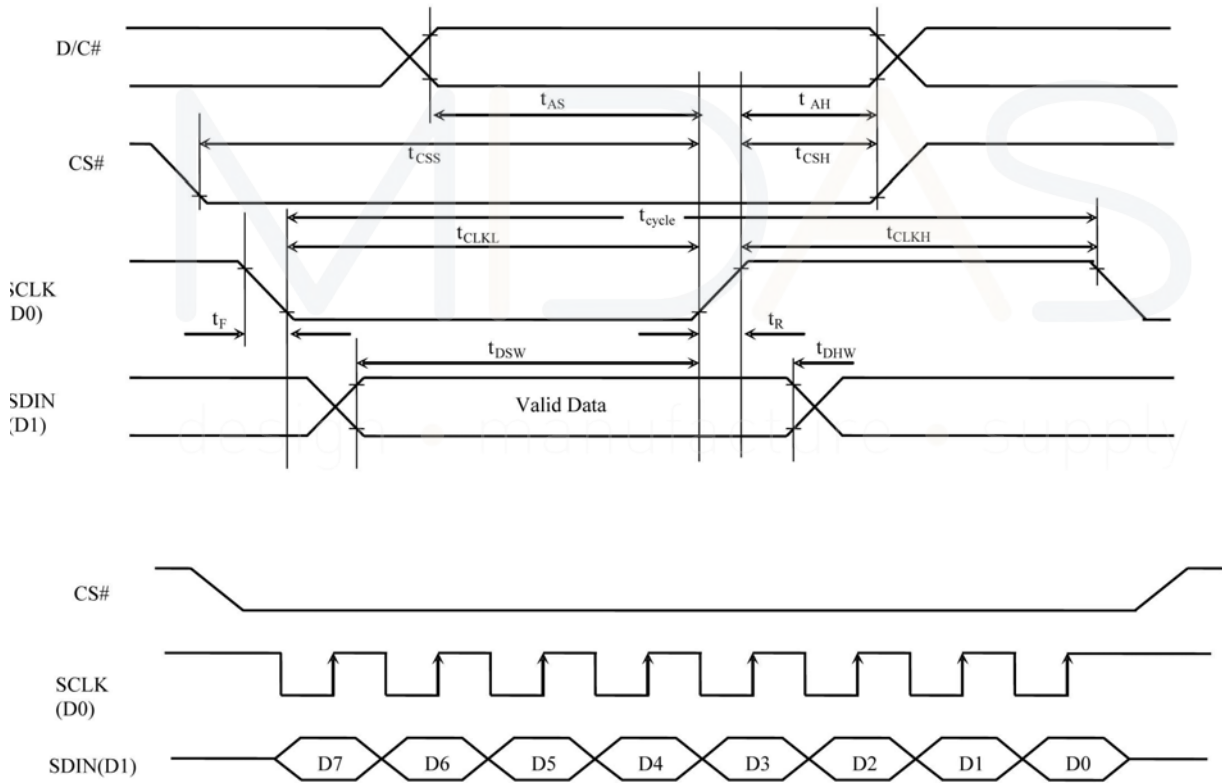

**Table 13-4 : Serial Interface Timing Characteristics (4-wire SPI)**

( $V_{DD} - V_{SS} = 2.4$  to  $2.6V$ ,  $V_{DDIO} = 1.6V$ ,  $V_{CI} = 3.3V$ ,  $T_A = 25^\circ C$ )

Symbol	Parameter	Min	Typ	Max	Unit
$t_{cycle}$	Clock Cycle Time	100	-	-	ns
$t_{AS}$	Address Setup Time	15	-	-	ns
$t_{AH}$	Address Hold Time	15	-	-	ns
$t_{CSS}$	Chip Select Setup Time	20	-	-	ns
$t_{CSH}$	Chip Select Hold Time	10	-	-	ns
$t_{DSW}$	Write Data Setup Time	15	-	-	ns
$t_{DHW}$	Write Data Hold Time	15	-	-	ns
$t_{CLKL}$	Clock Low Time	20	-	-	ns
$t_{CLKH}$	Clock High Time	20	-	-	ns
$t_R$	Rise Time	-	-	15	ns
$t_F$	Fall Time	-	-	15	ns

**Figure 13-3 : Serial interface characteristics (4-wire SPI)**



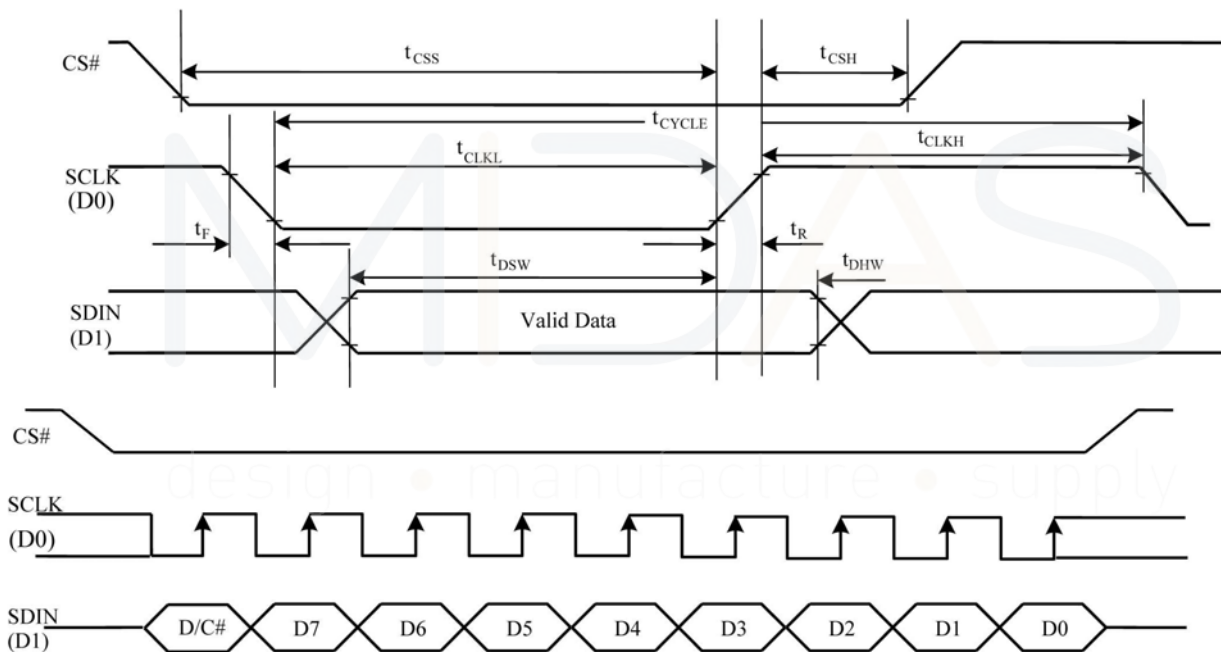

**Table 13-5: Serial Interface Timing Characteristics (3-wire SPI)**

( $V_{DD} - V_{SS} = 2.4$  to  $2.6V$ ,  $V_{DDIO} = 1.6V$ ,  $V_{CI} = 3.3V$ ,  $T_A = 25^\circ C$ )

Symbol	Parameter	Min	Typ	Max	Unit
$t_{cyle}$	Clock Cycle Time	100	-	-	ns
$t_{CSS}$	Chip Select Setup Time	20	-	-	ns
$t_{CSH}$	Chip Select Hold Time	10	-	-	ns
$t_{DSW}$	Write Data Setup Time	15	-	-	ns
$t_{DHW}$	Write Data Hold Time	15	-	-	ns
$t_{CLKL}$	Clock Low Time	20	-	-	ns
$t_{CLKH}$	Clock High Time	20	-	-	ns
$t_R$	Rise Time	-	-	15	ns
$t_F$	Fall Time	-	-	15	ns

**Figure 13-4: Serial interface characteristics (3-wire SPI)**



## 12. GDDRAM

### 12.1 GDDRAM structure in Gray Scale mode

The GDDRAM address map in Table 8-6 shows the GDDRAM in Gray Scale mode. Since in Gray

Scale mode, there are 16 gray levels. Therefore four bits (one nibble) are allocated for each pixel. For example D30480[3:0] in Table 8-6 corresponds to the pixel located in (COM127, SEG2). So the lower nibble and higher nibble of D0, D1, D2, ..., D30717, D30718, D30719 in Table 8-6 represent the 480x128 data nibbles in the GDDRAM.

**Table 8-6 : GDDRAM in Gray Scale mode (RESET)**

	SEG0	SEG1	SEG2	SEG3		SEG476	SEG477	SEG478	SEG479	SEG Outputs RAM Column address (HEX)
	00		00			77		77		
COM0	00	D1[3:0]	D1[7:4]	D0[3:0]	D0[7:4]	D239[3:0]	D239[7:4]	D238[3:0]	D238[7:4]	
COM1	01	D241[3:0]	D241[7:4]	D240[3:0]	D240[7:4]	D479[3:0]	D479[7:4]	D478[3:0]	D478[7:4]	
		⋮								
COM126	7E	D30241[3:0]	D30241[7:4]	D30240[3:0]	D30240[7:4]	D30479[3:0]	D30479[7:4]	D30478[3:0]	D30478[7:4]	
COM127	7F	D30481[3:0]	D30481[7:4]	D30480[3:0]	D30480[7:4]	D30719[3:0]	D30719[7:4]	D30718[3:0]	D30718[7:4]	

RAM Row Address (HEX) →

← Corresponding to one pixel

## 12.2 Data bus to RAM mapping

**Table 8-7 : Data bus usage**

Read / Write Data		Data bus D[7:0]							
Bus width	Input order	D7	D6	D5	D4	D3	D2	D1	D0
8 bits	1 <sup>st</sup>	3	3	3	3	2	2	2	2
	2 <sup>nd</sup>	1	1	1	1	0	0	0	0

← Corresponding to one pixel

## 14 . DESIGN AND HANDING PRECAUTION

14.1 The LCD panel is made by glass. Any mechanical shock (eg. Dropping form high place) will damage the LCD module. Do not add excessive force on the surface of the



display, which may cause the Display color change abnormally.

14.2 The polarizer on the LCD is easily get scratched. If possible, do not remove the LCD protective film until the last step of installation.

14.3 Never attempt to disassemble or rework the LCD module.

14.4 Only Clean the LCD with Isopropyl Alcohol or Ethyl Alcohol. Other solvents (eg. water) may damage the LCD.

14.5 When mounting the LCD module, make sure that it is free from twisting, warping and distortion.

14.6 Ensure to provide enough space(with cushion) between case and LCD panel to prevent external force adding on it, or it may cause damage to the LCD or degrade the display result

14.7 Only hold the LCD module by its side. Never hold LCD module by add force on the heat seal or TAB.

14.8 Never add force to component of the LCD module. It may cause invisible damage or degrade of the reliability.

14.9 LCD module could be easily damaged by static electricity. Be careful to maintain an optimum anti-static work environment to protect the LCD module.

14.10 When peeling of the protective film from LCD, static charge may cause abnormal display pattern. It is normal and will resume to normal in a short while.

14.11 Take care and prevent get hurt by the LCD panel edge.

14.12 Never operate the LCD module exceed the absolute maximum ratings.

14.13 Keep the signal line as short as possible to prevent noisy signal applying to LCD module.

14.14 Never apply signal to the LCD module without power supply.

14.15 IC chip (eg. TAB or COG) is sensitive to the light. Strong lighting environment could possibly cause malfunction. Light sealing structure casing is recommend.

14.16 LCD module reliability may be reduced by temperature shock.

14.17 When storing the LCD module, avoid exposure to the direct sunlight, high humidity, high temperature or low temperature. They may damage or degrade the LCD module

