

# Features

## Regulated Converters

- Highest power density in SIP Package
- 1.6kVDC/1 minute Isolation
- Efficiency up to 88%
- -40°C to +75°C Operating Temperature Range @ full load
- IEC/EN60950 (PENDING)
- CB Report
- Industry Standard Pinout

### Description

The RS6 series offer very high power density (2.7W/cm<sup>3</sup>), wide input voltage range and an industrial operating temperature range of -40°C to +75°C without derating. High efficiency, tight regulation, 2kVDC isolation and remote on/off are just some of the characteristics of this advanced SIP8 6W converter which is ideal for high density power supply designs in demanding industrial applications.

### Selection Guide

Part Number	nom. Input Voltage [VDC]	Output Voltage [VDC]	Output Current [mA]	Efficiency typ. <sup>(1)</sup> [%]	max. Capacitive Load <sup>(2)</sup> [µF]
RS6-053.3S	5	3.3	1300	83	6600
RS6-0505S	5	5	1200	86	3300
RS6-0512S	5	12	500	87	1600
RS6-0515S	5	15	400	86	1400
RS6-0505D	5	±5	±600	84	±2000
RS6-0512D	5	±12	±250	87	±900
RS6-0515D	5	±15	±200	86	±660
RS6-123.3S	12	3.3	1300	81	6600
RS6-1205S	12	5	1200	86	3300
RS6-1212S	12	12	500	87	1600
RS6-1215S	12	15	400	87	1400
RS6-1205D	12	±5	±600	85	±2000
RS6-1212D	12	±12	±250	87	±900
RS6-1215D	12	±15	±200	87	±660
RS6-243.3S	24	3.3	1300	81	6600
RS6-2405S	24	5	1200	87	3300
RS6-2412S	24	12	500	87	1600
RS6-2415S	24	15	400	87	1400
RS6-2405D	24	±5	±600	85	±2000
RS6-2412D	24	±12	±250	87	±900
RS6-2415D	24	±15	±200	87	±660
RS6-483.3S	48	3.3	1300	81	6600
RS6-4805S	48	5	1200	87	3300
RS6-4812S	48	12	500	87	1600
RS6-4815S	48	15	400	88	1400
RS6-4805D	48	±5	±600	85	±2000
RS6-4812D	48	±12	±250	87	±900
RS6-4815D	48	±15	±200	88	±660

#### Notes:

Note1: Efficiency tested by nominal input and full load at +25°C ambient.

Note2: Max Cap Load tested by minimum input and constant resistor load.

**RECOM**  
DC/DC Converter

## RS6

6 Watt  
SIP8  
Single and Dual  
Output

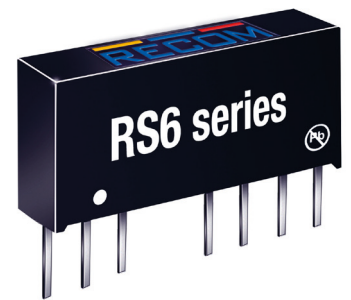

IEC/EN60950-1 (PENDING)  
EN55022 compliant

Specifications (measured @  $t_a = 25^\circ\text{C}$ , nominal input voltage, full load and after warm up unless otherwise specified)

### BASIC CHARACTERISTICS

Parameter	Condition		Min.	Typ.	Max.
Input Filter			Capacitor type		
Input Voltage Range	nom. Vin= 5V		4.5VDC	5VDC	9VDC
	nom. Vin= 12V		9VDC	12VDC	18VDC
	nom. Vin= 24V		18VDC	24VDC	36VDC
	nom. Vin= 48V		36VDC	48VDC	75VDC
Input Surge Voltage	1 second max.	nom. Vin= 5V nom. Vin= 12V nom. Vin= 24V nom. Vin= 48V			15VDC 25VDC 50VDC 100VDC
Quiescent Current		nom. Vin= 5V nom. Vin= 12V nom. Vin= 24V nom. Vin= 48V			105mA 55mA 28mA 14mA
Output Voltage Trimming	see calculation on next page	Trim up Trim down			+10% -8%
Start-up time				2ms	
Under Voltage Lockout	nom. Vin= 5V	DC-DC ON DC-DC OFF		4.5VDC 2.7VDC	
	nom. Vin= 12V	DC-DC ON DC-DC OFF		9VDC 7VDC	
	nom. Vin= 24V	DC-DC ON DC-DC OFF		18VDC 15VDC	
	nom. Vin= 48V	DC-DC ON DC-DC OFF		36VDC 30VDC	
ON/OFF CTRL		DC-DC ON DC-DC OFF			Open 5V < Vr < 10VDC
Internal Operating Frequency		0-100% load	200kHz		
Minimum Load				0%	
Output Ripple and Noise <sup>(3)</sup>		20MHz BW		50mVp-p	75mVp-p

#### Notes:

Note3: Measurements are made with a 1.0µF MLCC across output (low ESR).

#### Efficiency vs. Load

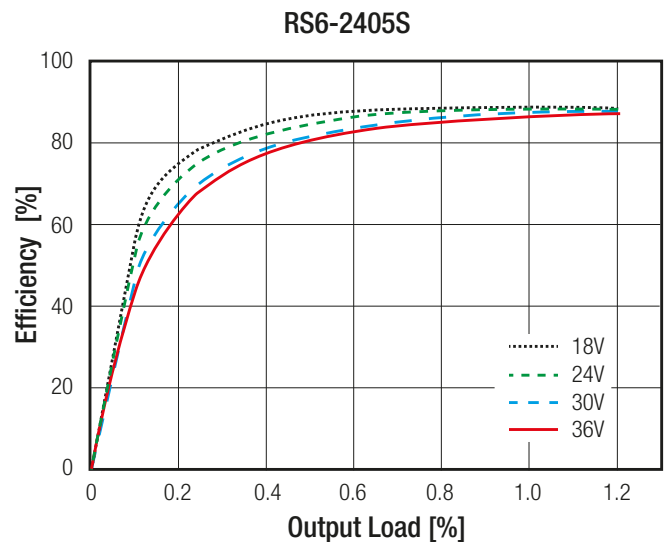
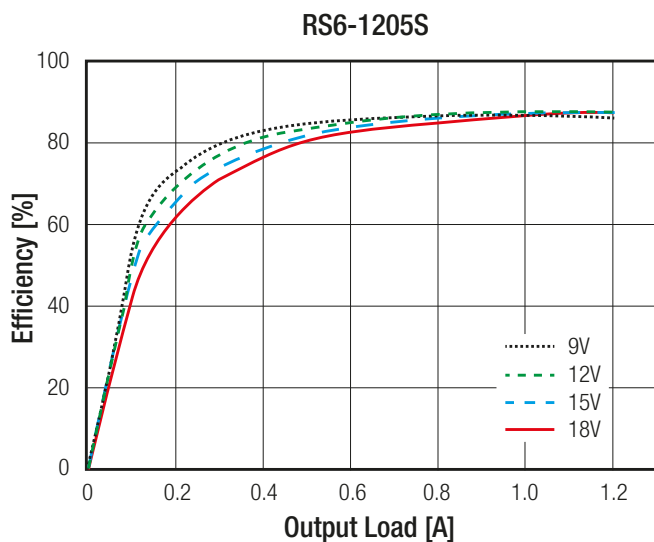

continued on next page

Specifications (measured @ ta= 25°C, nominal input voltage, full load and after warm up unless otherwise specified)

### Output Voltage Trimming

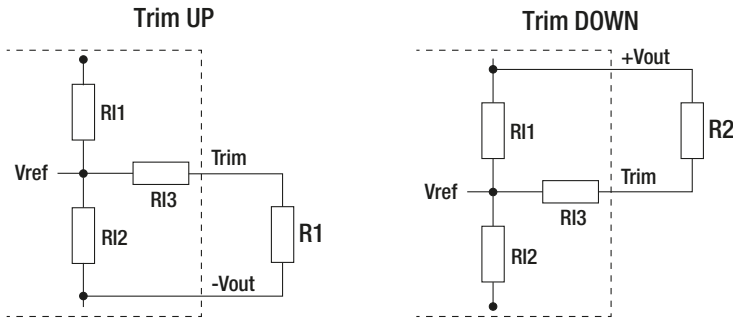

Vout	3.3V	5V	12V	15V
R11	16.74 kΩ	10 kΩ	38 kΩ	50 kΩ
R12	10 kΩ			
R13	52.3 kΩ	39 kΩ	68 kΩ	68 kΩ
Vref	1.24 V		2.5 V	

### Trim Calculation

$$R_1 = \left[ \frac{a \cdot R_{I2}}{R_{I2} - a} \right] - R_{I3} = k\Omega$$

$$a = \left[ \frac{V_{ref}}{\Delta V_{out} - V_{ref}} \right] * R_{I1} = k\Omega$$

$\Delta V_{out}$  = Output Voltage Trim

R1 = trim up resistor

R2 = trim down resistor

a = trim up factor

b = trim down factor

$$R_2 = \left[ \frac{b \cdot R_{I1}}{R_{I1} - b} \right] - R_{I3} = k\Omega$$

$$b = \left[ \frac{\Delta V_{out} - V_{ref}}{V_{ref}} \right] * R_{I2} = k\Omega$$

### Practical Example:

#### Trim Up:

Vout = 5V,  $\Delta V_{out}$  = 10% (5.5V), Vref = 2.5V

$$a = \left[ \frac{2.5V}{5.5V - 2.5V} \right] * 10k\Omega = 8.33k\Omega$$

$$R_1 = \left[ \frac{8.33k\Omega * 10k\Omega}{10k\Omega - 8.33k\Omega} \right] - 39 = 11.0k\Omega$$

#### RS6-xx03.3S

Trim up	1	2	3	4	5	6	7	8	9	10	%
Vout =	3.33	3.36	3.39	3.43	3.46	3.49	3.53	3.56	3.59	3.63	Volts
R <sub>1</sub> =	1151.73	360.87	197.07	126.28	86.79	61.60	44.14	31.32	21.15	13.76	KOhms

#### RS6-xx05S

Trim up	1	2	3	4	5	6	7	8	9	10	%
Vout =	5.05	5.10	5.15	5.20	5.25	5.30	5.35	5.4	5.45	5.50	Volts
R <sub>1</sub> =	461.00	211.00	127.67	86.00	61.00	44.33	32.43	23.50	16.56	11.00	KOhms

#### RS6-xx12S

Trim up	1	2	3	4	5	6	7	8	9	10	%
Vout =	12.12	12.24	12.36	12.48	12.60	12.72	12.84	12.96	13.08	13.20	Volts
R <sub>1</sub> =	723.67	327.83	195.89	129.92	90.33	63.94	45.10	30.96	19.96	11.17	KOhms

#### RS6-xx15S

Trim up	1	2	3	4	5	6	7	8	9	10	%
Vout =	5.05	5.10	5.15	5.20	5.25	5.30	5.35	5.4	5.45	5.50	Volts
R <sub>1</sub> =	765.33	348.67	209.78	140.33	98.67	70.89	51.05	36.17	24.59	15.33	KOhms

continued on next page

Specifications (measured @  $t_a = 25^\circ\text{C}$ , nominal input voltage, full load and after warm up unless otherwise specified)

### Trim down:

$V_{out} = 5V$ ,  $\Delta V_{out} = -8\%$  (4.5V),  $V_{ref} = 2.5V$

$$b = \left[ \frac{4.60V - 2.5V}{2.5V} \right] * 10k\Omega = 8.4k\Omega$$

$$R_2 = \left[ \frac{8.4k\Omega * 10k\Omega}{10k\Omega - 8.4k\Omega} \right] - 39k\Omega = 13.5k\Omega$$

### RS6-xx03.3S

Trim down	-1	-2	-3	-4	-5	-6	-7	-8	%
$V_{out} =$	3.267	3.234	3.201	3.168	3.135	3.102	3.069	3.036	Volts
$R_2 =$	643.60	355.96	233.75	166.13	123.19	93.52	71.78	55.17	KOhms

### RS6-xx05S

Trim down	-1	-2	-3	-4	-5	-6	-7	-8	%
$V_{out} =$	4.95	4.90	4.85	4.80	4.75	4.70	4.65	4.60	Volts
$R_2 =$	451.00	201.00	117.67	76.00	51.00	34.33	22.43	13.50	KOhms

### RS6-xx12S

Trim down	-1	-2	-3	-4	-5	-6	-7	-8	%
$V_{out} =$	11.88	11.76	11.64	11.52	11.40	11.28	11.16	11.04	Volts
$R_2 =$	2902.33	1398.17	896.78	646.08	495.67	395.39	323.76	270.04	KOhms

### RS6-xx15S

Trim down	-1	-2	-3	-4	-5	-6	-7	-8	%
$V_{out} =$	14.85	14.70	14.55	14.40	14.25	14.10	13.95	13.80	Volts
$R_2 =$	4048.67	1965.33	1270.89	923.67	715.33	576.44	477.24	402.83	KOhms

## REGULATIONS

Parameter	Condition	Values
Output Accuracy		$\pm 1\%$ typ.
Line Regulation	low line to high line	$\pm 0.2\%$ typ.
Load Regulation	0% to 100% load	$\pm 1\%$ typ.
Cross Regulation	25% to 100% load	$\pm 5\%$ typ.
Transient Response	25% load step change	500 $\mu\text{s}$ typ.

### Accuracy vs Load

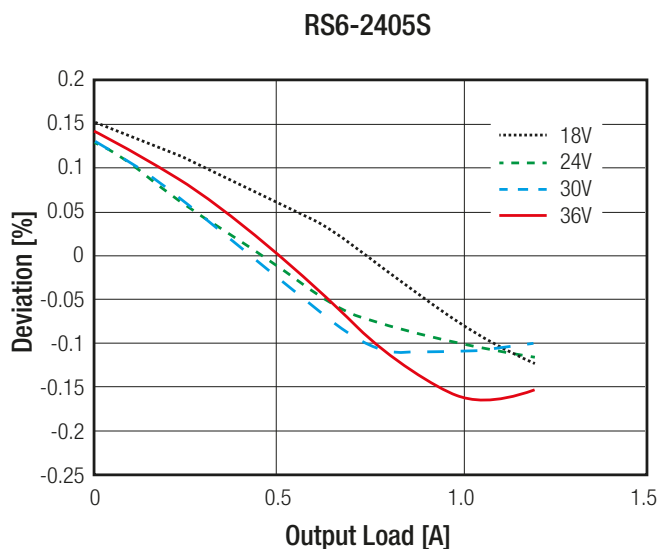
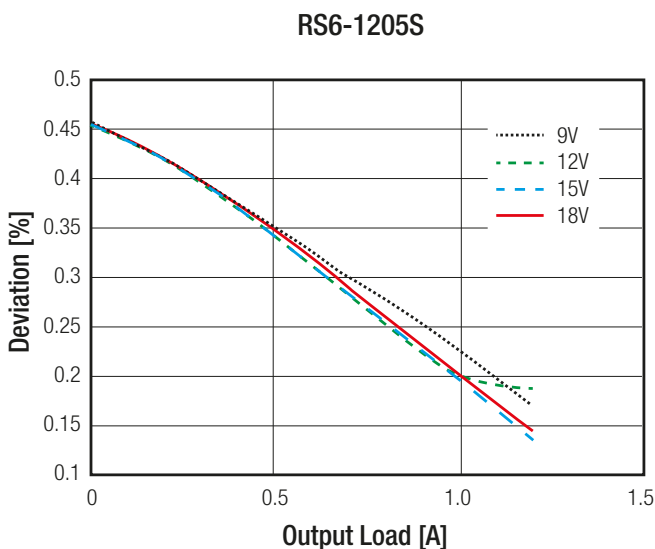

**Specifications** (measured @  $t_a = 25^\circ\text{C}$ , nominal input voltage, full load and after warm up unless otherwise specified)

PROTECTIONS		
Parameter	Condition	Value
Short Circuit Protection (SCP)	below 100mΩ	continuous, automatic recovery
Over Load Protection (OLP)		150% load, continuous, automatic recovery
Isolation Voltage	I/P to O/P	2kVDC / 1 second 1.6kVDC / 1 minute
Isolation Capacitance		110pF max.
Isolation Resistance		1GΩ typ.
Isolation Grade		Functional

ENVIRONMENTAL		
Parameter	Condition	Value
Operating Temperature Range <sup>(5)</sup>	without derating (see graph)	-40°C to +75°C
Maximum Case Temperature		+105°C
Temperature Coefficient		±0.02%/°C
Operating Humidity	non-condensing	5% - 95% RH max.
Vibration		MIL-STD-202G
MTBF	according to MIL-HDBK-217F +25°C	1776 x 10 <sup>3</sup> hours

**Derating Graph**

(@ Chamber and natural convection)

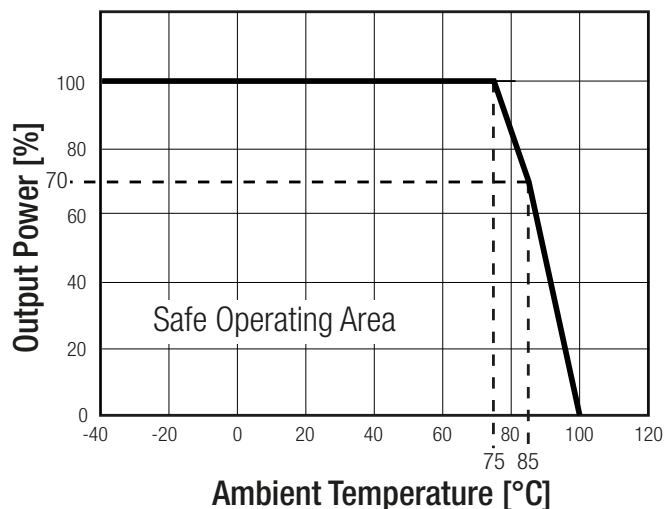

**Notes:**

Note5: Derating Graph is referring to RS6-0505S. For more details, please contact our technical support service at TechsupportAT@recom-power.com.

SAFETY AND CERTIFICATIONS		
Certificate Type	Report / File Number	Standard
Information Technology Equipment, General Requirements for Safety (CB Scheme)	PENDING	IEC60950-1, 2nd Edition, 2013 EN60950-1, 2nd Edition, 2013
RoHS 2.1		RoHS-2011/65/EU + AM-2015/863
EMC Compliance	Condition	Standard / Criterion
Information technology equipment - Radio disturbance characteristics - Limits and methods of measurement	see filter suggestions below	EN55022, Class B

continued on next page

**Specifications** (measured @  $t_a = 25^\circ\text{C}$ , nominal input voltage, full load and after warm up unless otherwise specified)

ESD Electrostatic discharge immunity test	$\pm 8\text{kV}$ Air Discharge, $\pm 6\text{kV}$ Contact Discharge	EN61000-4-2, Criteria A
Radiated, radio-frequency, electromagnetic field immunity test	10V/m	EN61000-4-3, Criteria A
Fast Transient and Burst Immunity	$\pm 2\text{kV}$	EN61000-4-4, Criteria A
Surge Immunity	$\pm 1\text{kV}$	EN61000-4-5, Criteria A
Immunity to conducted disturbances, induced by radio-frequency fields	10Vr.m.s	EN61000-4-6, Criteria A

### EMC Filtering - Suggestions for EN55022 Class A

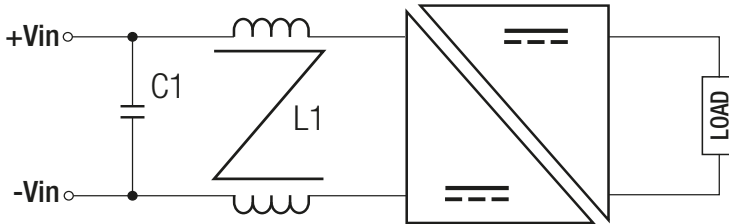

Model	C1	L1
RS6-05xx	22 $\mu\text{F}$	1 $\mu\text{H}$
RS6-12xx	4.7 $\mu\text{F}$	2.2 $\mu\text{H}$
RS6-24xx		6.8 $\mu\text{H}$
RS6-48xx		10 $\mu\text{H}$

### EMC Filtering - Suggestions for EN55022 Class B

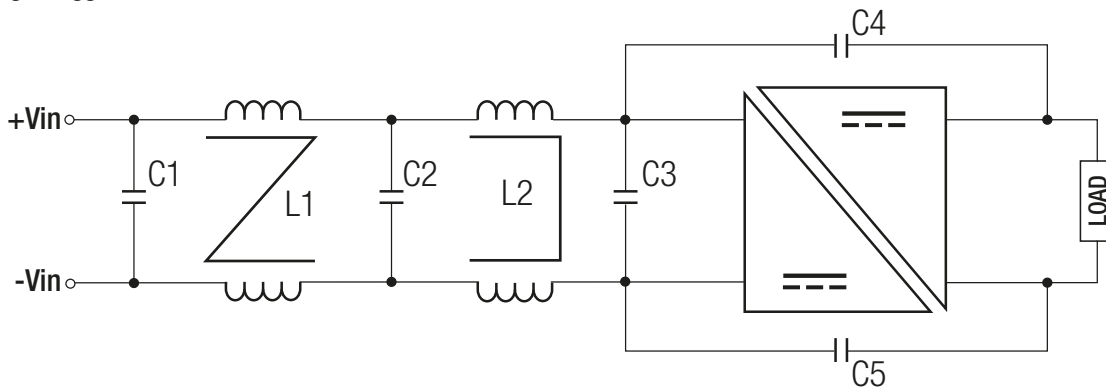

Model	C1	C2	C3	L1	L2	C4	C5
RS6-05xx	22 $\mu\text{F}$	10 $\mu\text{F}$	10 $\mu\text{F}$	200 $\mu\text{H}$	1 $\mu\text{H}$	47pF	100pF
RS6-12xx	10 $\mu\text{F}$		14.7 $\mu\text{F}$		6.8 $\mu\text{H}$		
RS6-24xx	4.7 $\mu\text{F}$	4.7 $\mu\text{F}$	4.7 $\mu\text{F}$		10 $\mu\text{H}$	56pF	220pF
RS6-48xx	4.4 $\mu\text{F}$	4.4 $\mu\text{F}$	1 $\mu\text{F}$			47pF	

### Surge Protection Circuit according to EN61000-4-5, Criteria A

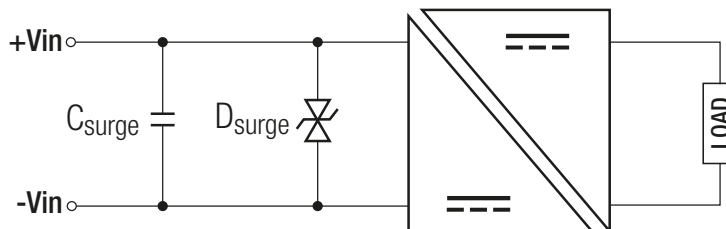

Input Voltage	Csurge	Dsurge	max. Surge Voltage
5VDC	100V, 220F E/Cap	TVS (P4SMAJ15CA)	$\pm 1\text{kVDC}$
12VDC		N/A	
24VDC			
48VDC			

**Specifications** (measured @  $t_a = 25^\circ\text{C}$ , nominal input voltage, full load and after warm up unless otherwise specified)

DIMENSION and PHYSICAL CHARACTERISTICS		
Parameter	Type	Value
Material	Case Potting	non conductive plastic (UL94V-0) Epoxy (UL94V-0)
Package Dimension (LxWxH)		21.8 x 9.2 x 11.1mm
Package Weight		4.0g

### Dimension Drawing (mm)

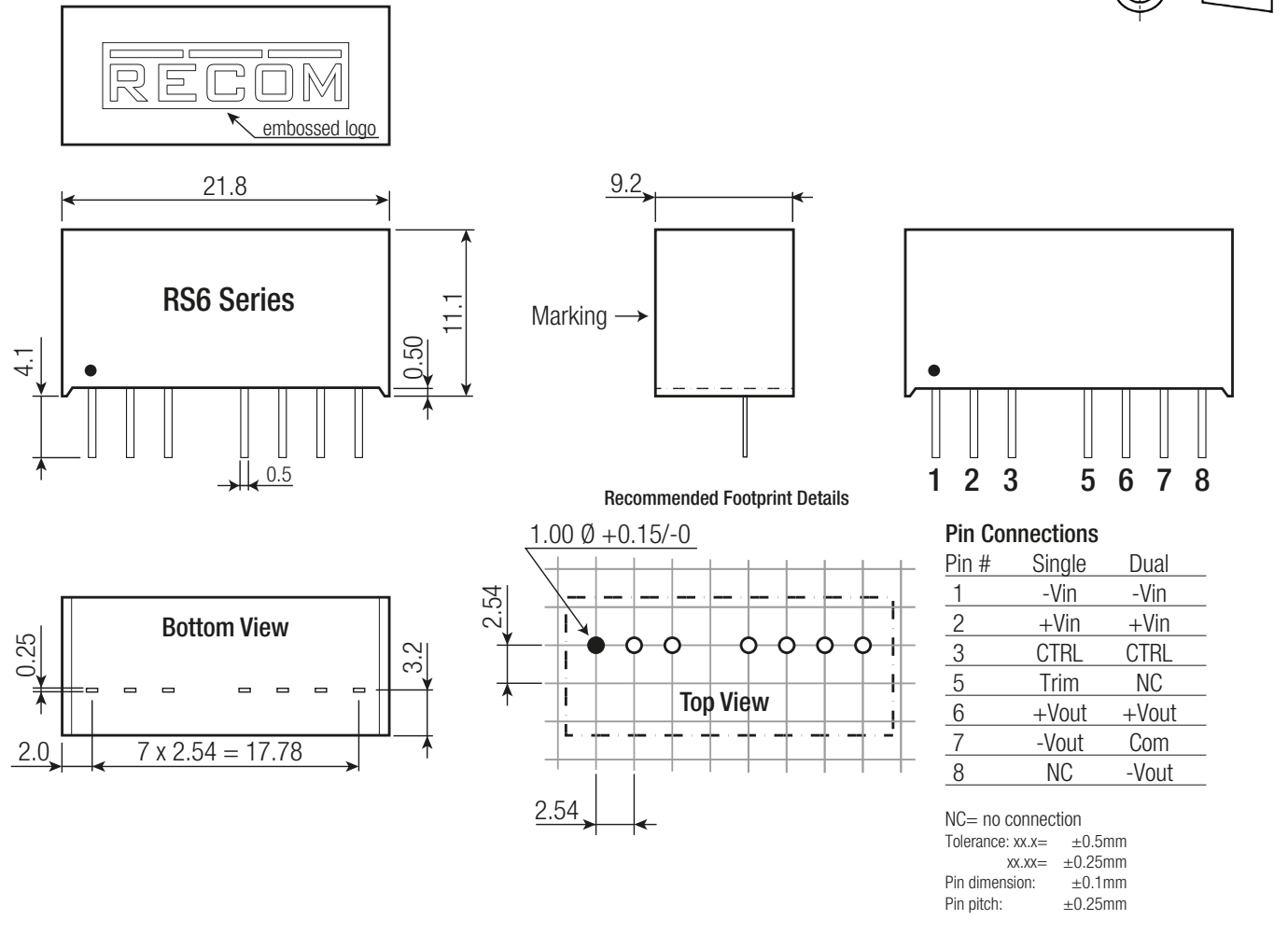

PACKAGING INFORMATION		
Packaging Dimension (LxWxH)	tube	520.0 x 18.2 x 11.2mm
Packaging Quantity		22 pcs
Storage Temperature Range		$-55^\circ\text{C}$ to $+125^\circ\text{C}$
Storage Humidity	non-condensing	95% RH max.

The product information and specifications are subject to change without prior notice. RECOM products are not authorized for use in safety-critical applications (such as life support) without RECOM's explicit written consent. A safety-critical application is defined as an application where a failure of a RECOM product may reasonably be expected to endanger or cause loss of life, inflict bodily harm or damage property. The buyer shall indemnify and hold harmless RECOM, its affiliated companies and its representatives against any damage claims in connection with the unauthorized use of RECOM products in such safety-critical applications.