

DO NOT SCALE DRAWING

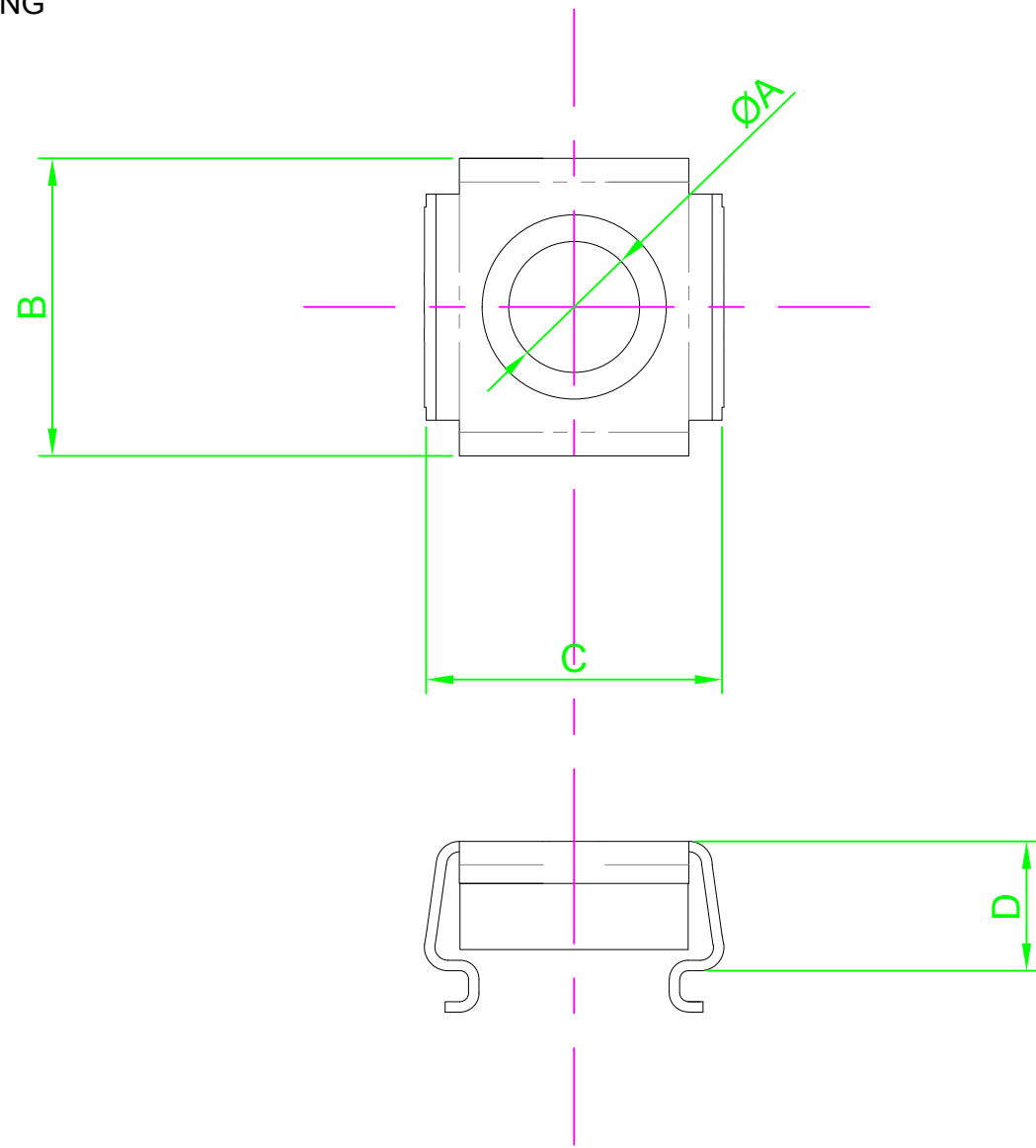

Recommended Mounting Hole

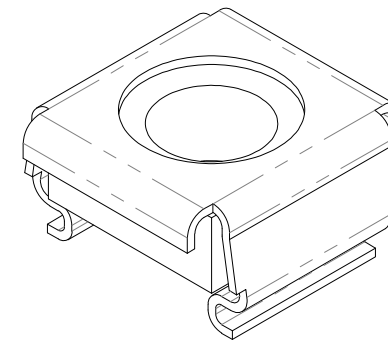
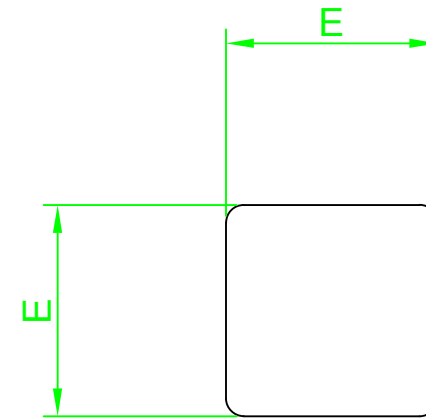

REVISION

A INITIAL DRAWING 04.02.16

Part Number	ØA	B Ref	C Ref	D Ref	E Ref	Panel Thickness
M5 - CNSTST B50 CN/5M/NF	M5-0.8	13.5	13.5	5.8	9.5	0.7 - 1.6mm
M6 - CNSTST B50 CN/6M/NF	M6-1.0					

NOTES:



UNLESS OTHERWISE SPECIFIED:
DIMENSIONS ARE IN MM (MILLIMETERS).
SURFACE FINISH:
TOLERANCES:

	NAME	DATE
DRAWN	Darryl Wilson	04.02.16
CHK'D		
APPV'D		

MATERIAL:
Steel

HEAT TREATMENT:

TITLE:
Cage Nut

DESIGN RIGHT. TR FASTENINGS LTD, 2003
UNDER NO CIRCUMSTANCES MUST THIS
DRAWING BE COPIED OR DISCLOSED
WITHOUT FIRST OBTAINING WRITTEN
AUTHORITY.

CUSTOMER PART NUMBER:
N/A

FINISH:
Zinc & Coloured Chromate Trivalent
De-Embrittle

DRAWING NUMBER:
TR32CNSTSTB50NARROW

A4

