

MAX14878–MAX14880

2.75kV and 5kV Isolated CAN Transceivers

General Description

The MAX14878–MAX14880 family of high-speed transceivers improve communication and safety by integrating galvanic isolation between the CAN protocol controller side of the device and the physical wires of the network (CAN) bus. Isolation improves communication by breaking ground loops and reduces noise where there are large differences in ground potential between ports. The MAX14879 provides up to 2750V_{RMS} (60s) of galvanic isolation, while the MAX14878/MAX14880 provide up to 5000V_{RMS} (60s) of galvanic isolation.

All transceivers operate up to the maximum high-speed CAN data rate of 1Mbps. The MAX14879/MAX14880 feature an integrated standby input (STB) on the isolated side of the transceiver to disable the driver and place the transceiver in a low-power standby mode. The MAX14878 does not include the standby input.

The MAX14878–MAX14880 transceivers feature integrated protection for robust communication. The receiver input common-mode range is $\pm 25V$, exceeding the ISO 11898 specification of $-2V$ to $+7V$, and are fault tolerant up to $\pm 54V$. Driver outputs/receiver inputs are also protected from $\pm 15kV$ electrostatic discharge (ESD) to GNDB on the bus side, as specified by the Human Body Model (HBM).

Interfacing with CAN protocol controllers is simplified by the wide 1.71V to 5.5V supply voltage range (V_{DDA}) on the controller side of the device. This supply voltage sets the interface logic levels between the transceiver and controller. The supply voltage range for the CAN bus side of the device is 4.5V to 5.5V (V_{DDB}).

The MAX14878–MAX14880 are available in a wide-body 16-pin SOIC package with 8mm of creepage and clearance. These devices operate over the $-40^{\circ}C$ to $+125^{\circ}C$ temperature range.

Applications

- Industrial Controls
- HVAC
- Building Automation
- Switching Gear

Benefits and Features

- Integrated Protection for Robust Communication
 - 2.75kV_{RMS} or 5kV_{RMS} Withstand Isolation Voltage for 60s (Galvanic Isolation)
 - $\pm 25V$ Receiver Input Common-Mode Range
 - $\pm 54V$ Fault Protection on Receiver Inputs
- High-Performance Transceiver Enables Flexible Designs
 - Wide 1.71V to 5.5V Supply for the CAN Controller Interface
 - Two Available 16-pin SOIC Package Pin Configurations
 - Data Rates up to 1Mbps (Max)
 - Dominant Timeout Protection

Safety Regulatory Approvals (Pending)

- UL According to UL1577 (Basic Insulation)
- IEC 61010

[Ordering Information](#) appears at end of data sheet.

Simplified Block Diagram

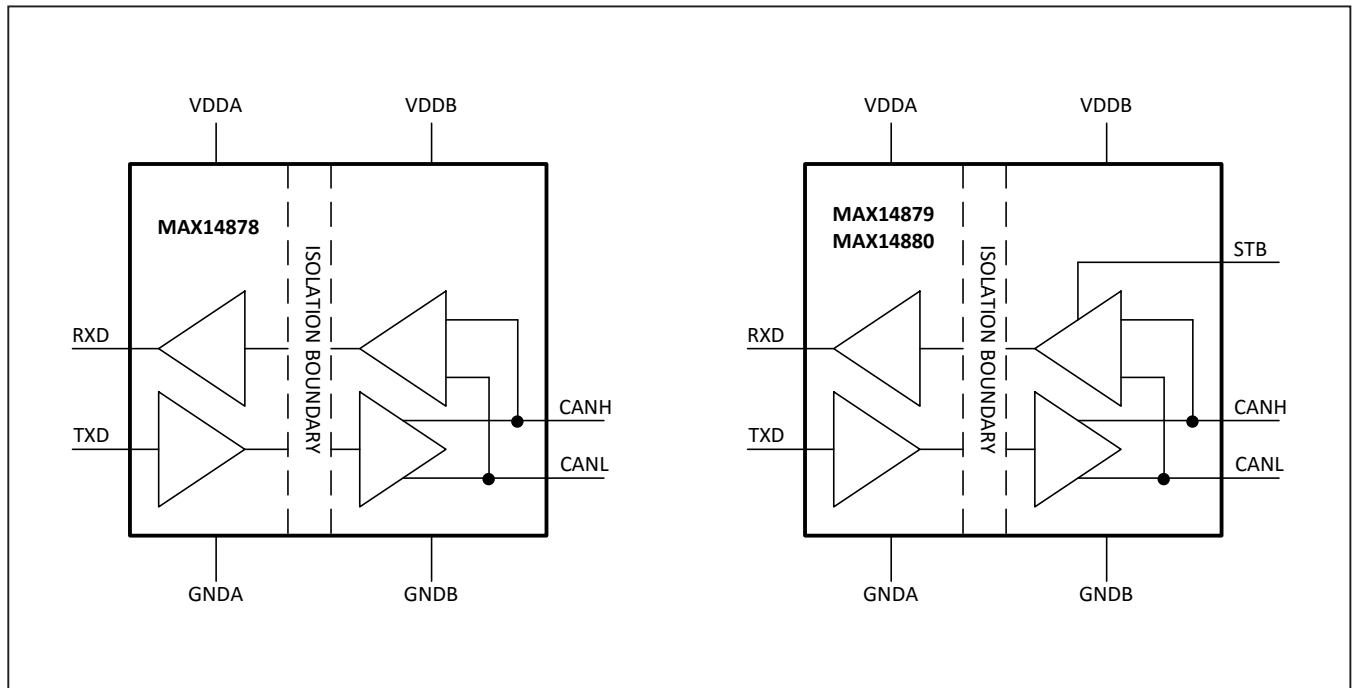

Absolute Maximum Ratings

V _{DDA} to GNDA.....	-0.3V to +6V	Short-Circuit Duration (RXD to GNDA or V _{DDA}).....	Continuous
V _{DDB} to GNDB.....	-0.3V to +6V	Continuous Power Dissipation (T _A = +70°C)	
TXD to GNDA.....	-0.3V to +6V	(16-pin W SOIC (derate 14.1mW/°C above +70°C))	. 1126.8mW
RXD to GNDA.....	-0.3V to (V _{DDA} + 0.3V)	Operating Temperature Range.....	-40°C to 125°C
STB to GNDB.....	-0.3V to +6V	Junction Temperature.....	+150°C
I.C. to GNDB.....	-0.3V to (V _{DDB} + 0.3V)	Storage Temperature Range.....	-60°C to +150°C
CANH or CANL to GNDB, (Continuous).....	-54V to +54V	Lead Temperature (soldering, 10s).....	+300°C
Short-Circuit Duration (CANH to CANL).....	Continuous	Soldering Temperature (reflow).....	+260°C

See Isolation section of the Electrical Characteristics table for maximum voltage from GNDA to GNDB

Stresses beyond those listed under "Absolute Maximum Ratings" may cause permanent damage to the device. These are stress ratings only, and functional operation of the device at these or any other conditions beyond those indicated in the operational sections of the specifications is not implied. Exposure to absolute maximum rating conditions for extended periods may affect device reliability.

Package Information

Wide 16-SOIC

PACKAGE CODE	W16M+9
Outline Number	21-0042
Land Pattern Number	90-0107
Thermal Resistance, Four-Layer Board:	
Junction to Ambient (θ _{JA})	71°C/W
Junction to Case (θ _{JC})	23°C/W

For the latest package outline information and land patterns (footprints), go to www.maximintegrated.com/packages. Note that a "+", "#", or "-" in the package code indicates RoHS status only. Package drawings may show a different suffix character, but the drawing pertains to the package regardless of RoHS status.

Package thermal resistances were obtained using the method described in JEDEC specification JESD51-7, using a four-layer board. For detailed information on package thermal considerations, refer to www.maximintegrated.com/thermal-tutorial.

Electrical Characteristics

(V_{DDA} = 1.71V to 5.5V, V_{DDB} = 4.5V to 5.5V, T_A = -40°C to +125°C, STB or I.C. = GNDB. Typical values are at T_A = +25°C with GNDA = GNDB, V_{DDA} = 3.3V, V_{DDB} = 5V. (Notes 1, 2))

PARAMETER	SYMBOL	CONDITIONS	MIN	TYP	MAX	UNITS
POWER						
Protocol Controller Side (A-Side) Voltage Supply	V _{DDA}		1.71		5.5	V
CAN Bus Side (B-Side) Voltage Supply	V _{DDB}		4.5		5.5	V
V _{DDA} Supply Current	I _{DDA}	V _{DDA} = 5V		0.34	0.83	mA
		V _{DDA} = 3.3V		0.34	0.76	
		V _{DDA} = 1.8V		0.33	0.64	

Electrical Characteristics (continued)

($V_{DDA} = 1.71V$ to $5.5V$, $V_{DDB} = 4.5V$ to $5.5V$, $T_A = -40^{\circ}C$ to $+125^{\circ}C$, STB or I.C. = GNDB. Typical values are at $T_A = +25^{\circ}C$ with GNDA = GNDB, $V_{DDA} = 3.3V$, $V_{DDB} = 5V$. (Notes 1, 2))

PARAMETER	SYMBOL	CONDITIONS	MIN	TYP	MAX	UNITS	
V _{DDB} Supply Current	I _{DDB}	V _{DDB} = 5V, TXD = GNDA, R _L = open		4.3	7.3	mA	
		V _{DDB} = 5V, TXD = GNDA, R _L = 60Ω		47.6	67.3		
		V _{DDB} = 5V, TXD = V _{DDA} , R _L = 60Ω		3.2			
		V _{DDB} = 5V, CANH shorted to CANL, TXD = V _{DDA}		3.2			
		V _{DDB} = 5V, CANH shorted to CANL, TXD = GNDA		94	140		
		V _{DDB} = 5V, TXD = V _{DDA} , R _L = 60Ω, STB = V _{DDB} (MAX14879/MAX14880)		0.4	0.8		
V _{DDA} Undervoltage Lockout Threshold, Rising	V _{DDAUVLO_R}				1.66	V	
V _{DDA} Undervoltage-Lockout Threshold, Falling	V _{DDAUVLO_F}		1.3	1.55		V	
V _{DDB} Undervoltage-Lockout Threshold, Rising	V _{DDBUVLO_R}				4.25	V	
V _{DDB} Undervoltage-Lockout Threshold, Falling	V _{DDBUVLO_F}		3.45			V	
CANH, CANL TRANSMITTER							
Dominant Output Voltage	V _{O(DOM)}	V _{TXD} = 0V, R _L = 50Ω to 65Ω	CANH	2.75		4.5	V
			CANL	0.5		2.25	
Dominant Differential Bus Output Voltage	V _{OD}	(V _{CANH} - V _{CANL}), V _{TXD} = 0V, R _L = 50Ω to 65Ω, Figure 1	R _{CM} is open	1.5		3	V
			R _{CM} = 1.25kΩ, -17V < V _{CM} < +17V	1.5		3	
			R _{CM} = 1.25kΩ, -25V < V _{CM} < +25V	1.1		3	
Recessive Voltage Output	V _{OR}	V _{TXD} = V _{DDA} , No load	CANH	2		3	V
			CANL	2		3	
Short-Circuit Current	I _{SHORT}	V _{TXD} = 0V	CANH shorted to GNDB	50	75	100	mA
			CANL shorted to V _{DDB}	50	75	100	
Recessive Differential Bus Output Voltage	V _{ODR}	(V _{CANH} - V _{CANL}), V _{TXD} = V _{DDA}	R _L is open	-500		+50	mV
			R _L = 60Ω	-120		+12	

Electrical Characteristics (continued)

($V_{DDA} = 1.71V$ to $5.5V$, $V_{DDB} = 4.5V$ to $5.5V$, $T_A = -40^{\circ}C$ to $+125^{\circ}C$, STB or I.C. = GNDB. Typical values are at $T_A = +25^{\circ}C$ with $GNDA = GNDB$, $V_{DDA} = 3.3V$, $V_{DDB} = 5V$. (Notes 1, 2))

PARAMETER	SYMBOL	CONDITIONS	MIN	TYP	MAX	UNITS	
CANH/CANL Output Voltage in Standby Mode	V_{STB}	MAX14879/MAX14880 only, $V_{TXD} = V_{DDA}$, No load, STB = V_{DDB}	70		175	mV	
DC BUS RECEIVER (CANH and CANL externally driven)							
Common Mode Input Range	V_{CM}	CANH or CANL to GNDB, RXD output valid	Normal operation	-25		+25	V
			Standby mode (MAX14879/MAX14880 only)	-12		+12	
Differential Input Voltage	V_{DIFF}	$V_{TXD} = V_{DDA}$	Recessive	0.5			V
			Dominant, No load			0.9	
Differential Input Hysteresis	$V_{DIFF(HYST)}$			125		mV	
Standby Mode Differential Input Voltage		MAX14879/MAX14880 only, $V_{TXD} = V_{DDA}$, $V_{STB} = V_{DDB}$	Recessive	0.45			V
			Dominant			1.15	
Common-Mode Input Resistance	R_{IN}	$V_{TXD} = V_{DDA}$, $R_{IN} = \Delta V / \Delta I$, $\Delta V = +300mV$, $V_{STB} = GNDB$ (MAX14879/MAX14880)	10		50	k Ω	
Differential Input Resistance	R_{ID}	$V_{TXD} = V_{DDA}$, $R_{ID} = \Delta V / \Delta I$, $\Delta V = +300mV$, $V_{STB} = GNDB$ (MAX14879/MAX14880)	20		100	k Ω	
Input Leakage Current	I_{LKG}	$V_{DDB} = 0V$, $V_{CANH} = V_{CANL} = 5V$			310	μA	
Input Capacitance	C_{IN}	CANH or CANL to GNDB (Note 3)		14.4	20	pF	
Differential Input Capacitance	C_{IND}	CANH to CANL (Note 3)		7.2	10	pF	

Electrical Characteristics (continued)

($V_{DDA} = 1.71V$ to $5.5V$, $V_{DDB} = 4.5V$ to $5.5V$, $T_A = -40^{\circ}C$ to $+125^{\circ}C$, STB or I.C. = GNDB. Typical values are at $T_A = +25^{\circ}C$ with $GNDA = GNDB$, $V_{DDA} = 3.3V$, $V_{DDB} = 5V$. (Notes 1, 2))

PARAMETER	SYMBOL	CONDITIONS		MIN	TYP	MAX	UNITS
LOGIC INTERFACE (RXD, TXD, STB)							
Input High Voltage	V_{IH}	TXD	$1.71V \leq V_{DDA} < 2.25V$	$0.75 \times V_{DDA}$			V
			$2.25V \leq V_{DDA} \leq 5.5V$	$0.7 \times V_{DDA}$			
		STB (MAX14879/MAX14880 only)	$0.7 \times V_{DDB}$				
Input Low Voltage	V_{IL}	TXD, $1.71 \leq V_{DDA} < 2.25V$				0.7	V
		TXD, $2.25V \leq V_{DDA} \leq 5.5V$				0.8	
		STB (MAX14879/MAX14880 only)				0.8	
Output High Voltage	V_{OH}	RXD, $I_{SOURCE} = 4mA$		$V_{DDA} - 0.4$			V
Output Low Voltage	V_{OL}	RXD, $I_{SINK} = 4mA$				0.4	V
Input Pullup Current	I_{PU}	TXD		-10	-5	-1.5	μA
Input Pulldown Resistance	R_{PD}	STB (MAX14879/MAX14880 only)		75		250	$k\Omega$
Input Capacitance					5		pF
PROTECTION							
Fault Protection Range		CANH to GNDB, CANL to GNDB		-54		+54	V
ESD Protection (CANH and CANL to GNDB)		IEC 61000-4-2 Air-Gap Discharge			± 10		kV
		IEC 61000-4-2 Contact Discharge			± 5		
		Human Body Model			± 15		
ESD Protection (CANH and CANL to GNDA)		IEC 61000-4-2 Contact Discharge			± 3		kV
		IEC 61000-4-2 Air Gap Discharge. 330pF capacitor connected between GNDA and GNDB			± 10		
ESD Protection (All Other Pins)		Human body model			± 2		kV
Thermal Shutdown Threshold		Temperature rising			+160		$^{\circ}C$
Thermal Shutdown Hysteresis					13		$^{\circ}C$

Electrical Characteristics - Switching

($V_{DDA} = 1.71V$ to $5.5V$, $V_{DDB} = 4.5V$ to $5.5V$, $T_A = -40^{\circ}C$ to $+125^{\circ}C$, STB or I.C. = GNDB. Typical values are at $T_A = +25^{\circ}C$ with GNDA = GNDB, $V_{DDA} = 3.3V$, $V_{DDB} = 5V$, STB = GNDB.)

PARAMETER	SYMBOL	CONDITIONS	MIN	TYP	MAX	UNITS
Differential Driver Output Rise Time	t_R	$R_L = 60\Omega$, $C_L = 100pF$, R_{CM} is open, Figure 1			20	ns
Differential Driver Output Fall Time	t_F	$R_L = 60\Omega$, $C_L = 100pF$, R_{CM} is open, Figure 1			33	ns
TXD to RXD Loop Delay	t_{LOOP}	$R_L = 60\Omega$, $C_L = 100pF$, $C_{RXD} = 15pF$, Dominant to recessive and recessive to dominant. Figure 2			210	ns
TXD Propagation Delay	t_{PDTXD_RD}	$R_L = 60\Omega$, $C_L = 100pF$, R_{CM} open, Figure 1			95	ns
	t_{PDTXD_DR}					
RXD Propagation Delay	t_{PDRXD_RD}	$C_L = 15pF$, Figure 3			115	ns
	t_{PDRXD_DR}					
TXD Dominant Timeout	t_{DOM}	(Note 4)	1.4		4.8	ms
Undervoltage Detection Time to Normal Operation	$t_{UV(VDDA)}$, $t_{UV(VDDB)}$			110	230	μs
Wake-up Time to Dominant State	t_{WAKE}	MAX14879/MAX14880 only, In standby mode ($V_{STB} = V_{DDB}$), Figure 4	0.5		5	μs
Standby Propagation Delay		MAX14879/MAX14880 only, RXD, Dominant to recessive, $V_{STB} = V_{DDB}$, $C_L = 15pF$		285	500	ns
Standby to Normal Mode Delay	t_{EN}	MAX14879/MAX14880 only			40	μs
Normal to Standby Dominant Mode Delay		MAX14879/MAX14880 only, ($V_{CANH} - V_{CANL}$) > 1.2V			65	μs

Electrical Characteristics—Package Insulation and Safety Related Specifications: W 16-SOIC

($V_{DDA} = 1.71V$ to $5.5V$, $V_{DDB} = 4.5V$ to $5.5V$, $T_A = -40^{\circ}C$ to $+125^{\circ}C$, STB or I.C. = GNDB. Typical values are at $T_A = +25^{\circ}C$ with $GNDA = GNDB$, $V_{DDA} = 3.3V$, $V_{DDB} = 5V$, STB = GNDB.)

PARAMETER	SYMBOL	CONDITIONS	VALUE	UNITS
Insulation Resistance	RIO	$T_A = +150^{\circ}C$, $V_{IO} = 500V$	$> 10^{12}$	Ω
Barrier Capacitance	C_{IO}	GNDA to GNDB	2	pF
Minimum Creepage Distance	CPG		8	mm
Minimum Clearance Distance	CLR		8	mm
Internal Clearance		Distance through insulation	0.015	mm
Comparative Tracking Index	CTI		550	

Electrical Characteristics—Insulation Characteristics (As Defined by VDE 0884-10): W 16-SOIC

($V_{DDA} = 1.71V$ to $5.5V$, $V_{DDB} = 4.5V$ to $5.5V$, $T_A = -40^{\circ}C$ to $+125^{\circ}C$, STB or I.C. = GNDB. Typical values are at $T_A = +25^{\circ}C$ with $GNDA = GNDB$, $V_{DDA} = 3.3V$, $V_{DDB} = 5V$, STB = GNDB.)

PARAMETER	SYMBOL	CONDITIONS	VALUE	UNITS	
Partial Discharge	V_{PR}	Method B1 = $V_{IORM} \times 1.875$ (t = 1s, partial discharge < 5pC)	MAX14879	1182	V_P
			MAX14878/ MAX14880	2250	
Maximum Repetitive Peak Voltage	V_{IORM}	MAX14879	630	V_P	
		MAX14878/MAX14880	1200		
Maximum Working Voltage	V_{IOWM}	GNDA to GNDB continuous	MAX14879	445	V_{RMS}
			MAX14878/ MAX14880	848	
Maximum Transient Overvoltage	V_{IOTM}	MAX14879	4600	V_P	
		MAX14878/MAX14880	8400		
Isolation Voltage	V_{SIO}	GNDA to GNDB for 60s	MAX14879	2.75	kV_{RMS}
			MAX14878/ MAX14880	5	
Maximum Surge Isolation Voltage	V_{IOSM}	IEC 61000-4-5, Basic insulation	10	kV	
Barrier Resistance	RS	$T_A = +150^{\circ}C$, $V_{IO} = 500V$	$> 10^9$	Ω	
Climate Category			40/125/21		
Pollution Degree		DIN VDE 0110, Table 1	2		

Note 1: All devices 100% production tested at $T_A = +25^{\circ}C$. Specifications over temperature are guaranteed by design.

Note 2: All currents into the device are positive. All currents out of the device are negative. All voltages referenced to their respective ground (GNDA or GNDB), unless otherwise noted.

Note 3: Not production tested. Guaranteed at $T_A = +25^{\circ}C$.

Note 4: The dominant timeout feature releases the bus when TX is held low longer than t_{DO} . CAN protocol guarantees a maximum of 11 successive dominant bits in any transmission. The minimum data rate allowed by the dominant timeout, then, is $11/t_{DO}(\text{min})$.

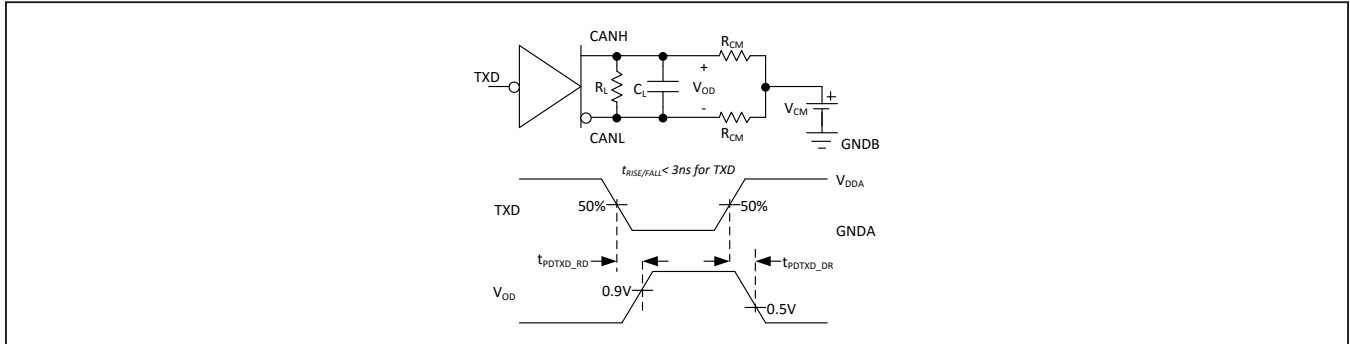

Figure 1. Transmitter Test Circuit and Timing Diagram

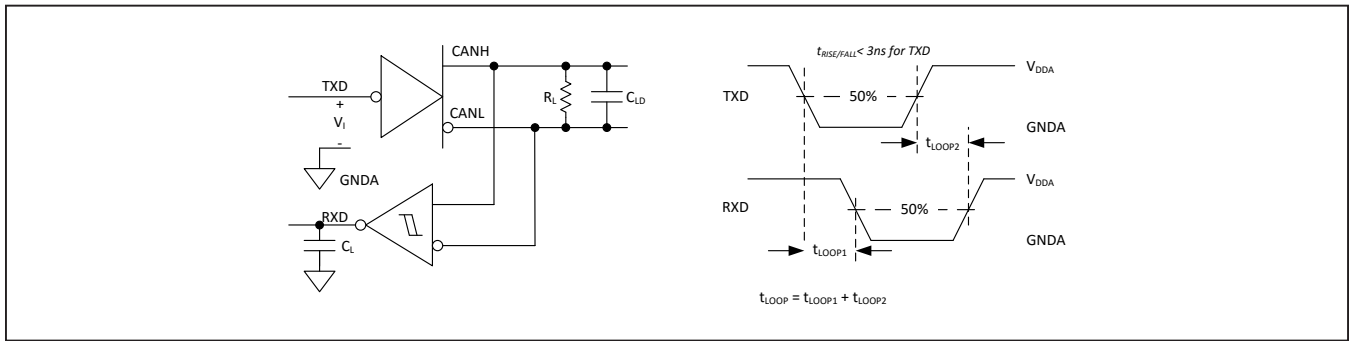

Figure 2. TXD to RXD Loop Delay

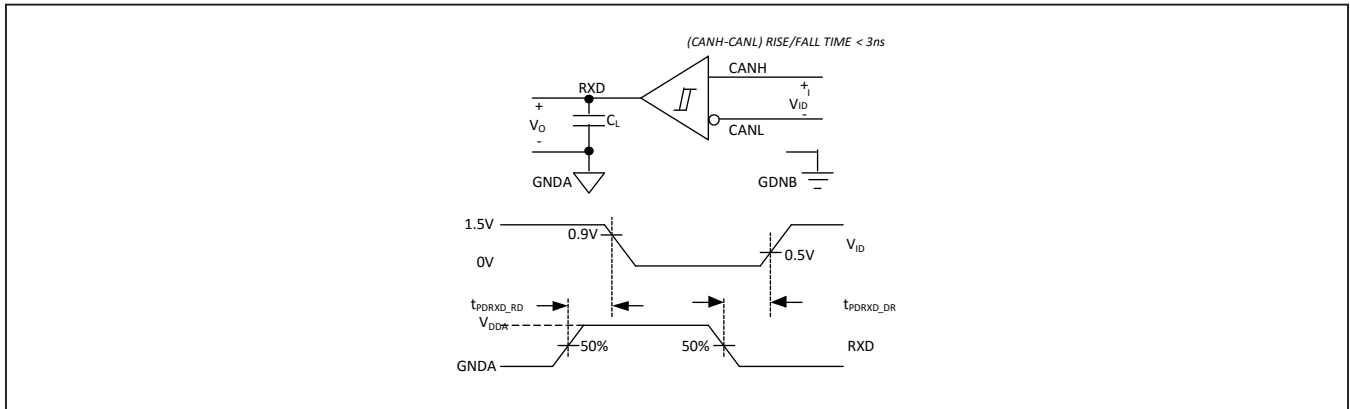

Figure 3. Receiver Timing Diagram

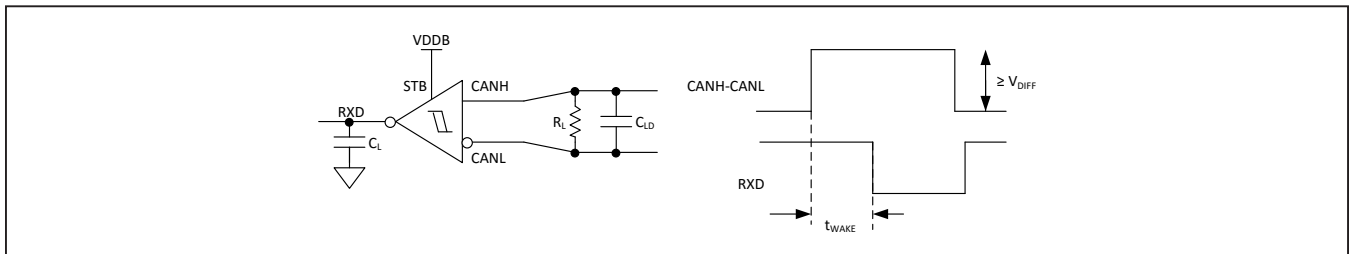
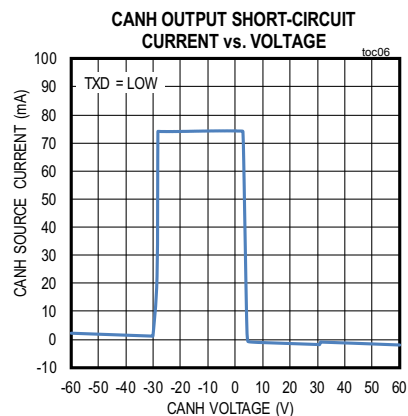
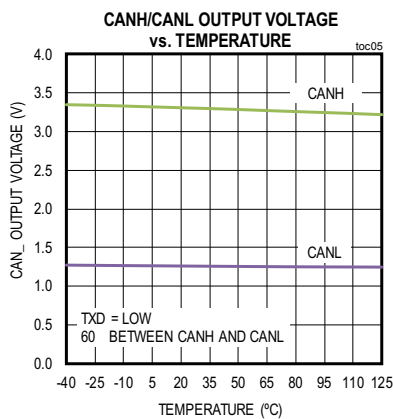
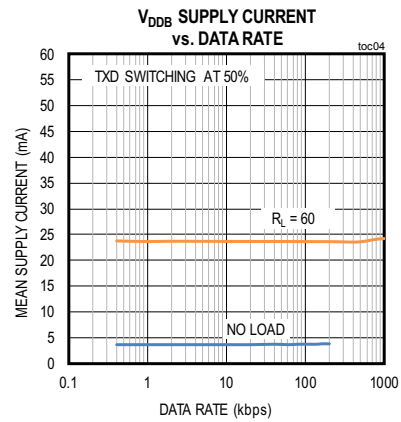
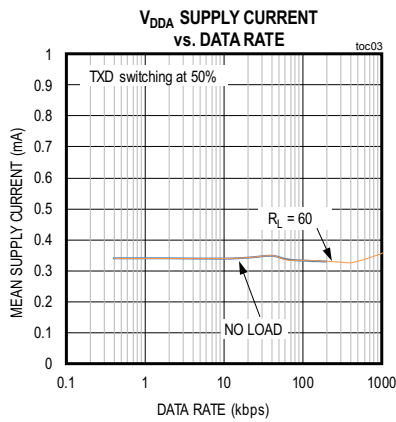
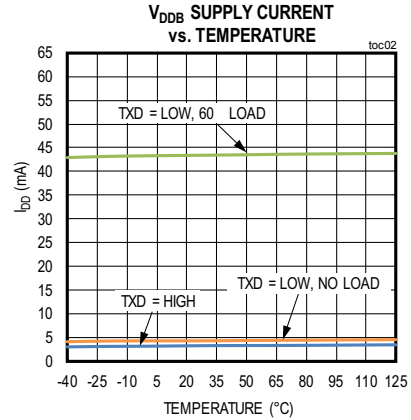
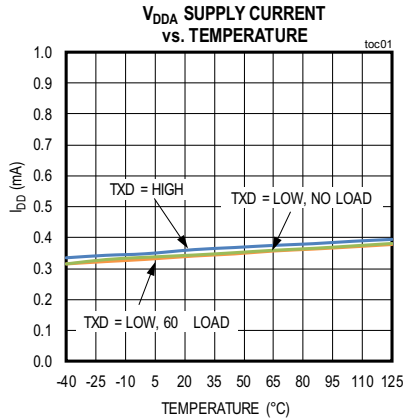

Figure 4. MAX14879/MAX14880 STB to RXD Delay

Typical Operating Characteristics

$V_{DDA} = 3.3V$, $V_{DDB} = 5V$, 60Ω load between CANH and CANL, $T_A = +25^\circ C$, unless otherwise noted.



Typical Operating Characteristics (continued)

$V_{DDA} = 3.3V$, $V_{DDB} = 5V$, 60Ω load between CANH and CANL, $T_A = +25^{\circ}C$, unless otherwise noted.

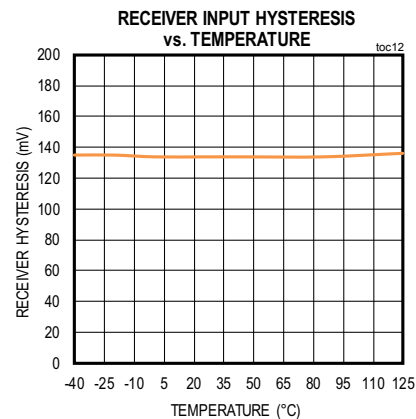
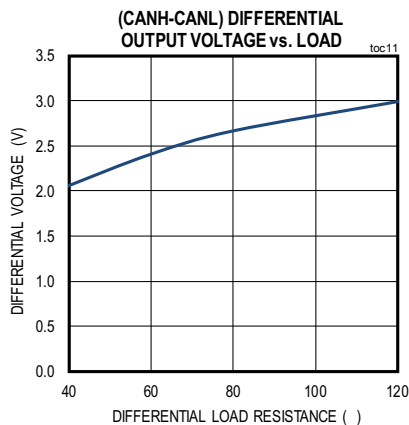
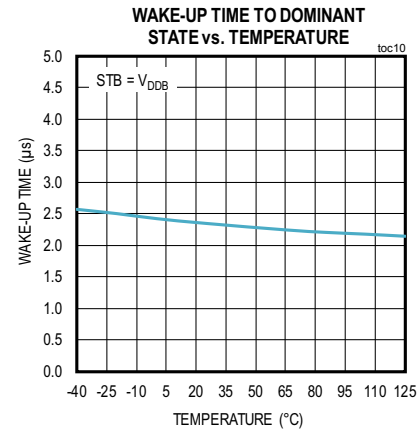
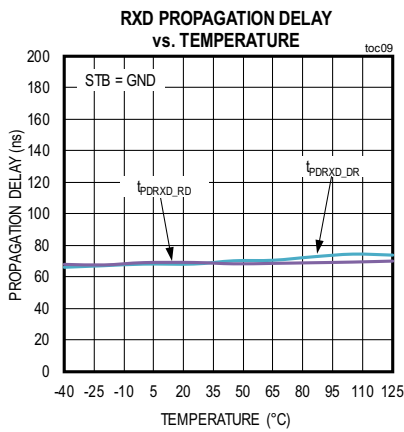
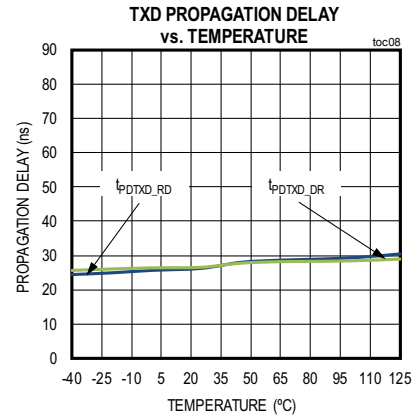
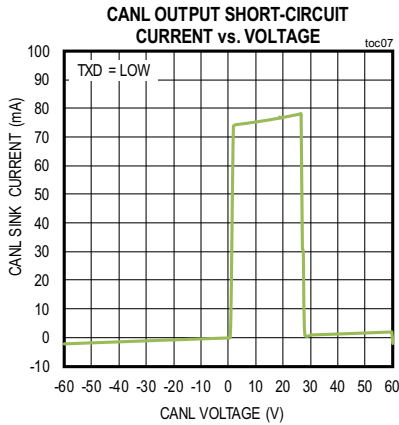

Pin Configuration

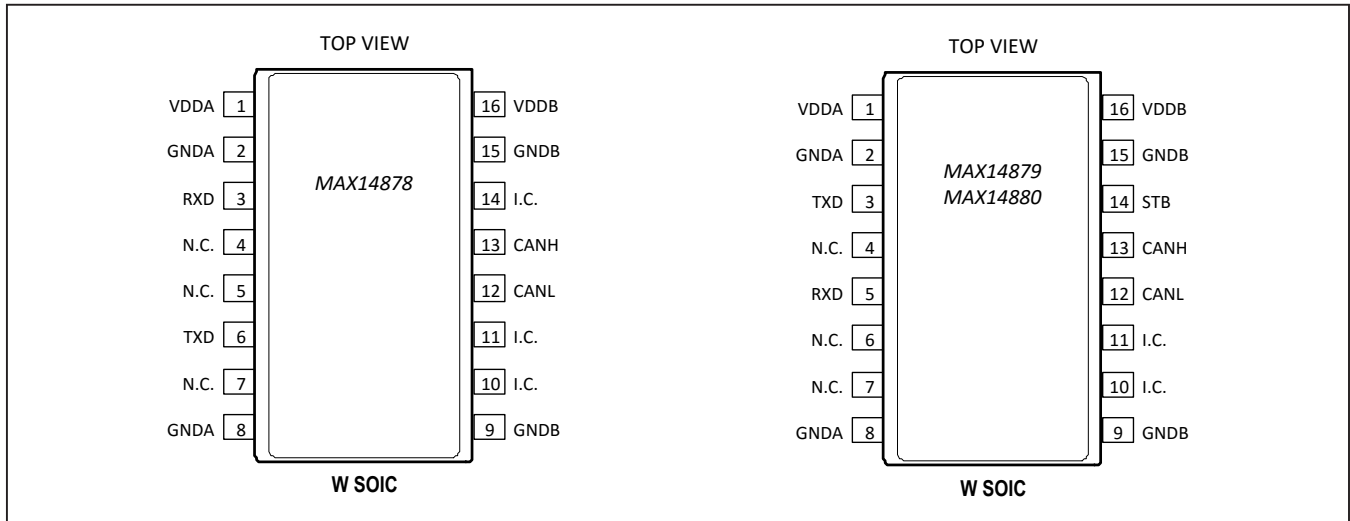

Pin Description

PIN		NAME	FUNCTION	REF SUPPLY	TYPE
MAX14878	MAX14879, MAX14880				
CONTROLLER SIDE (A-SIDE)					
1	1	V _{DDA}	Power Supply Input for the Controller Side/A-Side. Bypass V _{DDA} to GNDA with 0.1µF capacitor as close to the device as possible.	V _{DDA}	Power
2, 8	2, 8	GNDA	Controller Side/A-Side Ground	V _{DDA}	Ground
3	5	RXD	Receiver Output. RXD is high when the bus is in the recessive state. RXD is low when the bus is in the dominant state.	V _{DDA}	Digital Output
4, 5, 7	4, 6, 7	N.C.	No Connection. Not internally connected. Connect to GNDA, V _{DDA} , or leave unconnected.		
6	3	TXD	Transmit Data Input. CANH and CANL are in the dominant state when TXD is low. CANH and CANL are in the recessive state when TXD is high.	V _{DDA}	Digital Input
CAN BUS SIDE (B-SIDE)					
9, 15	9, 15	GNDB	CAN Bus Side/B-Side Ground	V _{DDB}	Ground
10, 11, 14	10, 11	I.C.	Internally Connected. Connect to GNDB.		
12	12	CANL	Low-Level CAN Differential Bus Line	V _{DDB}	Differential I/O
13	13	CANH	High-Level CAN Differential Bus Line	V _{DDB}	Differential I/O
-	14	STB	Standby Input, Active High. Drive STB high to disable the CAN bus driver and place the transceiver in low-power standby mode. Drive STB low for normal operation.	V _{DDB}	Digital Input
16	16	V _{DDB}	Power Supply Input for the CAN Bus Side/B-Side. Bypass V _{DDB} to GNDB with a 0.1µF capacitor as close to the device as possible.	V _{DDB}	Power

Detailed Description

The MAX14878–MAX14880 isolated controller area network (CAN) transceivers provide 2750V_{RMS} or 5000V_{RMS} (60s) of galvanic isolation between the cable side (B-side) of the transceiver and the controller side (A-side). These devices allow up to 1Mbps communication across an isolation barrier when a large potential exists between grounds on each side of the barrier.

CANH and CANL outputs are short-circuit current limited and are protected against excessive power dissipation by thermal shutdown circuitry that places the driver outputs in a high-impedance state.

Isolation

Data isolation is achieved using integrated capacitive isolation that allows data transmission between the controller side and cable side of the transceiver.

Fault Protection

The MAX14878–MAX14880 feature ±54V fault protection on the CANH and CANL bus lines. When CANH or CANL is pulled above +30V (typ) or below -30V (typ), the I/O is set to high impedance. This wide fault protection range simplifies selecting external TVS components for surge protection.

Transmitter

The transmitter converts a single-ended input signal (TXD) from the CAN controller to differential outputs for the bus lines (CANH, CANL). The truth table for the transmitter and receiver is given in Table 1.

Transmitter Dominant Timeout

The MAX14878–MAX14880 feature a transmitter-dominant timeout (t_{DOM}) that prevents erroneous CAN controllers from clamping the bus to a dominant level by maintaining a continuous low TXD signal. When TXD remains in the dominant state (low) for greater than t_{DOM} , the transmitter is disabled, releasing the bus to a recessive state (Table 1).

After a dominant timeout fault, normal transmitter function is re-enabled on the rising edge of a TXD.

The transmitter-dominant timeout limits the minimum possible data rate to 9kbps for standard CAN protocol.

Driver Output Protection

The MAX14878–MAX14880 feature integrated circuitry to protect the transmitter output stage against a short-circuit to a positive or negative voltage by limiting the driver current. The transmitter returns to normal operation once the short is removed.

Thermal shutdown further protects the transceiver from excessive temperatures that may result from a short by setting the transmitter outputs to high impedance when the junction temperature exceeds +160°C (typ). The transmitter returns to normal operation when the junction temperature falls below the thermal shutdown hysteresis.

Receiver

The receiver reads the differential input from the bus (CANH, CANL) and transfers this data as a single-ended output (RXD) to the CAN controller. During normal operation, a comparator senses the difference between CANH and CANL, $V_{DIFF} = (V_{CANH} - V_{CANL})$, with respect to an internal threshold of 0.7V (typ). If $V_{DIFF} > 0.9V$, a logic-low is present on RXD. If $V_{DIFF} < 0.5V$, a logic-high is present.

The CANH and CANL common-mode range is ±25V. RXD is logic-high when CANH and CANL are shorted or terminated and undriven.

Thermal Shutdown

If the junction temperature exceeds +160°C (typ), the device is switched off. During thermal shutdown, CANH and CANL are high-impedance and all IC functions are disabled. The transmitter outputs are re-enabled and the device resumes normal operation when the junction temperature drops below 147°C (typ).

Table 1. Transmitter and Receiver Truth Table When Not Connected to the Bus

TXD	TXD LOW TIME	CANH	CANL	BUS STATE	RXD
LOW	< t_{DOM}	HIGH	LOW	DOMINANT	LOW
LOW	> t_{DOM}	$V_{DDB}/2$	$V_{DDB}/2$	RECESSIVE	HIGH
HIGH	X	$V_{DDB}/2$	$V_{DDB}/2$	RECESSIVE	HIGH

Applications Information

Reduced EMI and Reflections

In multidrop CAN applications, it is important to maintain a single linear bus of uniform impedance that is properly terminated at each end. A star configuration should never be used.

Any deviation from the end-to-end wiring scheme creates a stub. High-speed data edges on a stub can create reflections back down the bus. These reflections can cause data errors by eroding the noise margin of the system. Although stubs are unavoidable in a multidrop system, care should be taken to keep these stubs as short as possible, especially when operating with high data rates.

Typical Operating Circuit

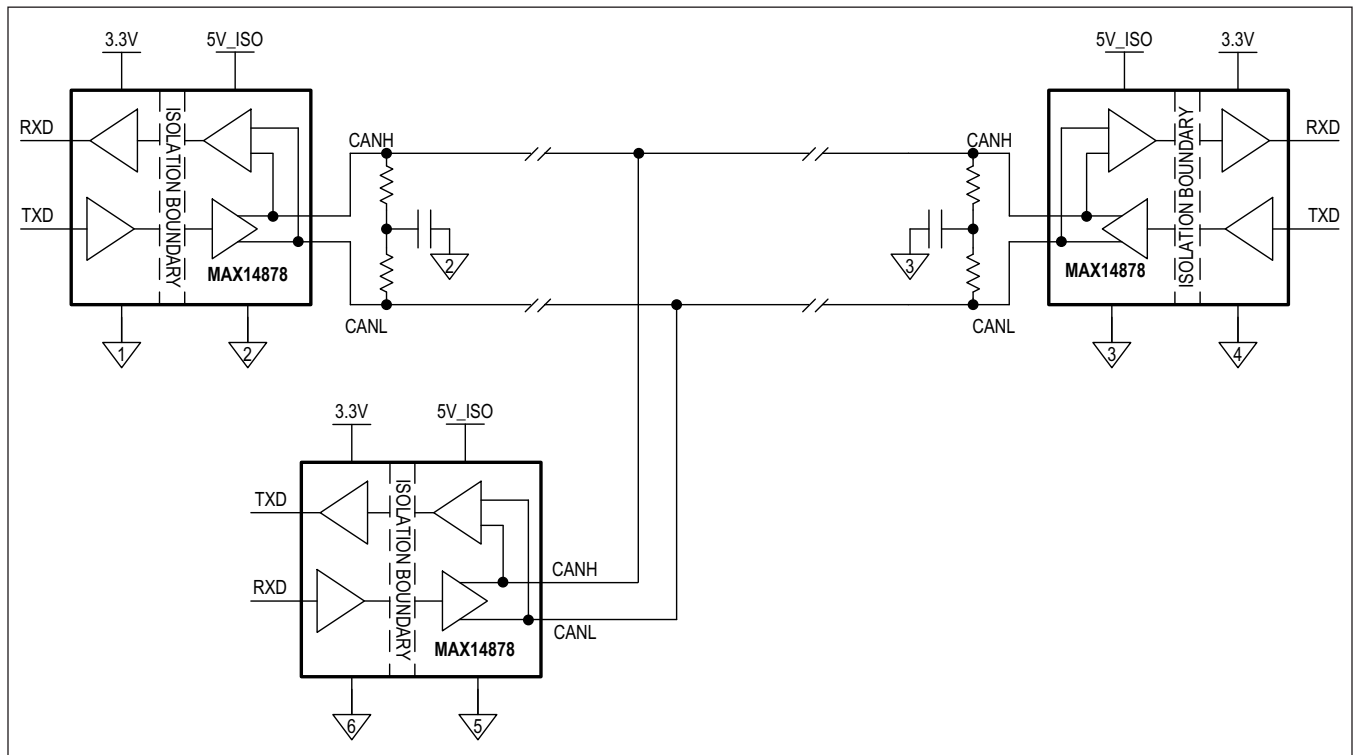

Ordering Information

PARTNUMBER	ISOLATION VOLTAGE	STANDBY	OPERATING TEMPERATURE	PACKAGE
MAX14878AWE+	5kV _{RMS}	NO	-40°C to +125°C	W 16-SOIC
MAX14878AWE+T	5kV _{RMS}	NO	-40°C to +125°C	W 16-SOIC
MAX14879AWE+	2.75kV _{RMS}	YES	-40°C to +125°C	W 16-SOIC
MAX14879AWE+T	2.75kV _{RMS}	YES	-40°C to +125°C	W 16-SOIC
MAX14880AWE+	5kV _{RMS}	YES	-40°C to +125°C	W 16-SOIC
MAX14880AWE+T	5kV _{RMS}	YES	-40°C to +125°C	W 16-SOIC

Revision History

REVISION NUMBER	REVISION DATE	DESCRIPTION	PAGES CHANGED
0	6/17	Initial release	—
1	8/17	Updated parameters in <i>Electrical Characteristics</i> table and added <i>Typical Operating Circuit</i>	7, 14

For pricing, delivery, and ordering information, please contact Maxim Direct at 1-888-629-4642, or visit Maxim Integrated's website at www.maximintegrated.com.

Maxim Integrated cannot assume responsibility for use of any circuitry other than circuitry entirely embodied in a Maxim Integrated product. No circuit patent licenses are implied. Maxim Integrated reserves the right to change the circuitry and specifications without notice at any time. The parametric values (min and max limits) shown in the *Electrical Characteristics* table are guaranteed. Other parametric values quoted in this data sheet are provided for guidance.