

Features

- Output Capable of Sourcing and Sinking 2A
- CMOS and TTL Compatible Inputs
- 5V to 24V Supply Voltage Range
- UVLO
- Fast Propagation Delays (13ns typical)
- Fast Rise and Fall Times (7ns typical)
- ±2kV ESD Rating (Human Body Model)

Applications

- Switch-Mode Power Supplies
- DC-DC Converters
- Motor Controllers
- Power Inverters

Description

The IX4310T is a 2A low side gate driver. The output is capable of sourcing and sinking 2A of peak current, and has a maximum voltage rating of 24V.

The input is TTL and CMOS logic compatible.

The IX4310T is available in a 5-pin SOT23 package.

Ordering Information

| Part Number | Description |
|-------------|-------------------------|
| IX4310TTR | 5-Pin SOT23 (3000/Reel) |

IX4310T Functional Block Diagram

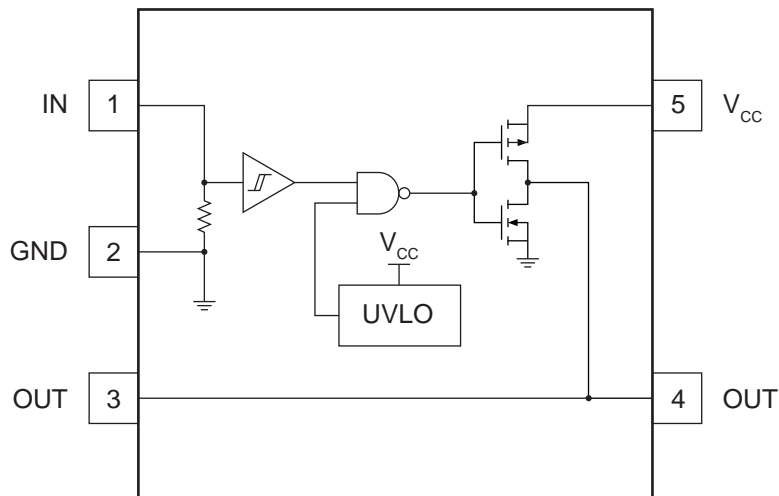

| | |
|--|----------|
| 1. Specifications | 3 |
| 1.1 Pin Configuration | 3 |
| 1.2 Logic Table | 3 |
| 1.3 Pin Definitions | 3 |
| 1.4 Absolute Maximum Ratings | 3 |
| 1.5 Recommended Operating Conditions | 4 |
| 1.6 Electrical Characteristics | 4 |
| 1.7 Thermal Characteristics | 4 |
| 2. Performance Data | 5 |
| 3. Manufacturing Information | 7 |
| 3.1 Moisture Sensitivity | 7 |
| 3.2 ESD Sensitivity | 7 |
| 3.3 Soldering Profile | 7 |
| 3.4 Board Wash | 7 |
| 3.5 Mechanical Dimensions | 8 |

1 Specifications

1.1 Pin Configuration

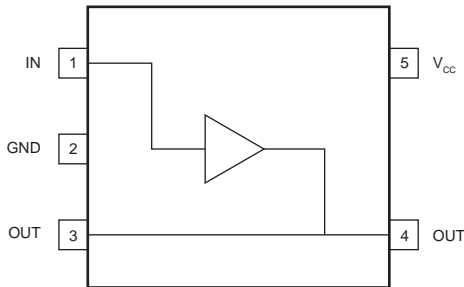

1.2 Logic Table

| IN | V _{CC} | OUT |
|----|-------------------------------------|-----|
| 1 | V _{CC} >UVLO _{ON} | 1 |
| 0 | V _{CC} >UVLO _{ON} | 0 |
| x | V _{CC} <UVLO _{ON} | 0 |

1.3 Pin Definitions

| Pin # | Name | Description |
|-------|-----------------|---|
| 1 | IN | Driver logic input. Internally pulled to GND |
| 2 | GND | Ground. Common ground reference for the device |
| 3, 4 | OUT | Driver output, capable of sourcing and sinking 2A |
| 5 | V _{CC} | Supply voltage |

1.4 Absolute Maximum Ratings

| Parameter | Symbol | Minimum | Maximum | Units |
|-------------------------------|------------------|---------|---------|-------|
| Supply Voltage | V _{CC} | -0.3 | 24 | V |
| Input Voltage | V _{IN} | -0.3 | 24 | V |
| Output Current | I _{OUT} | - | ±2 | A |
| ESD Rating (Human Body Model) | V _{ESD} | -2000 | +2000 | V |
| Junction Temperature | T _J | -55 | +150 | °C |
| Storage Temperature | T _{STG} | -65 | +150 | °C |

Absolute maximum electrical ratings are at 25°C

Absolute maximum ratings are stress ratings. Stresses in excess of these ratings can cause permanent damage to the device. Functional operation of the device at conditions beyond those indicated in the operational sections of this data sheet is not implied.

Typical values are characteristic of the device at +25°C, and are the result of engineering evaluations. They are provided for information purposes only, and are not part of the manufacturing testing requirements.

1.5 Recommended Operating Conditions

| Parameter | Symbol | Minimum | Maximum | Units |
|---------------------|----------|---------|---------|-------|
| Supply Voltage | V_{CC} | 4.5 | 20 | V |
| Ambient Temperature | T_A | -40 | +125 | °C |

1.6 Electrical Characteristics

$V_{CC} = 12V$, $T_J = -40^{\circ}C$ to $+125^{\circ}C$, unless otherwise noted.

| Parameter | Conditions | Symbol | Minimum | Typical | Maximum | Units |
|-------------------------------------|--|--------------|---------|---------|---------|----------|
| Supply | | | | | | |
| Supply Current | OUT Open | I_{CC} | - | 0.5 | 1.2 | mA |
| Under Voltage Lockout (UVLO) | | | | | | |
| UVLO Rising Threshold | V_{CC} Rising | $UVLO_{ON}$ | 3.5 | 3.85 | 4.2 | V |
| UVLO Falling Threshold | V_{CC} Falling | $UVLO_{OFF}$ | 3.1 | 3.3 | 3.5 | |
| UVLO Threshold Hysteresis | - | $UVLO_{HYS}$ | 0.2 | 0.5 | 0.8 | |
| Logic Inputs (IN) | | | | | | |
| Input Low Voltage | - | V_{IL} | - | - | 0.8 | V |
| Input High Voltage | - | V_{IH} | 2.5 | - | - | |
| Output Driver (OUT) | | | | | | |
| Output Pull-Up Resistance | $I_{OUT} = -100mA$, $T_J = 25^{\circ}C$ | R_{OH} | - | 1.9 | 3 | Ω |
| | $I_{OUT} = -100mA$ | | - | 2.6 | 3.4 | |
| Output Pull-Down Resistance | $I_{OUT} = 100mA$, $T_J = 25^{\circ}C$ | R_{OL} | - | 1.1 | 2 | |
| | $I_{OUT} = 100mA$ | | - | 1.5 | 2.3 | |
| Rise Time | $C_{LOAD} = 1nF$ | t_R | - | 7 | 15 | ns |
| Fall Time | $C_{LOAD} = 1nF$ | t_F | - | 7 | 15 | |
| Propagation Delay, Low to High | $C_{LOAD} = 1nF$ | t_{DLH} | 5 | 16 | 30 | |
| Propagation Delay, High to Low | $C_{LOAD} = 1nF$ | t_{DHL} | 5 | 16 | 30 | |

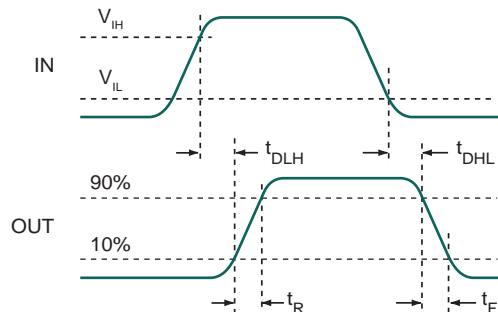

1.7 Thermal Characteristics

| Parameter | Symbol | Rating | Units |
|--|---------------|--------|-------|
| Thermal Impedance, Junction-to-Ambient | θ_{JA} | 221 | °C/W |

2 Performance Data

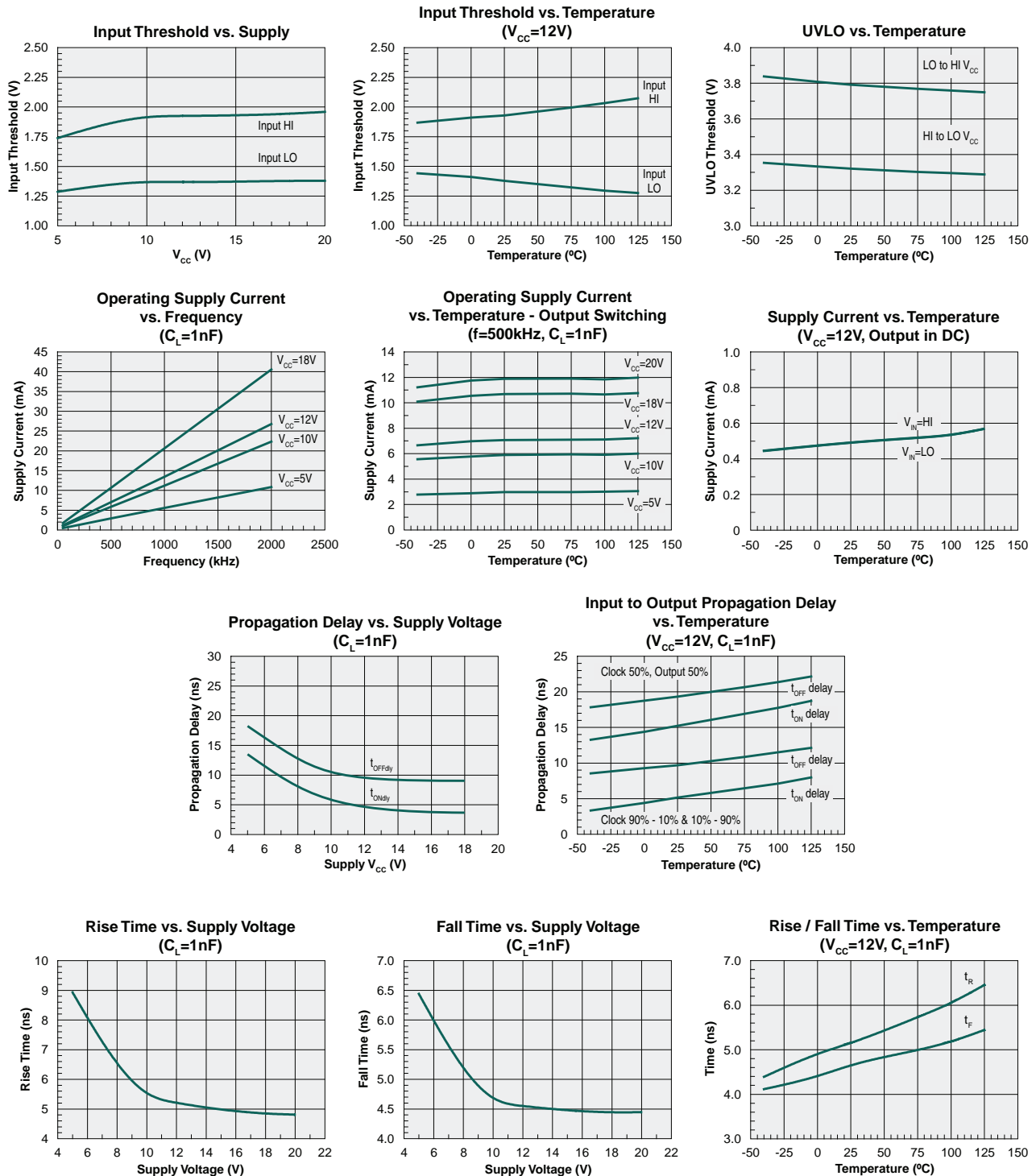

*Unless otherwise noted, data presented in these graphs is typical of device operation at 25 $^{\circ}C$.

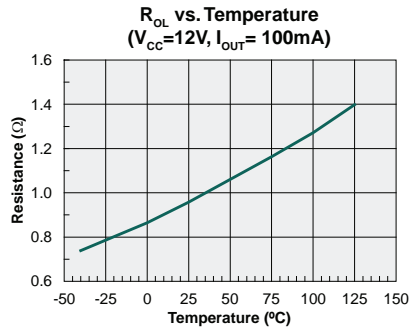
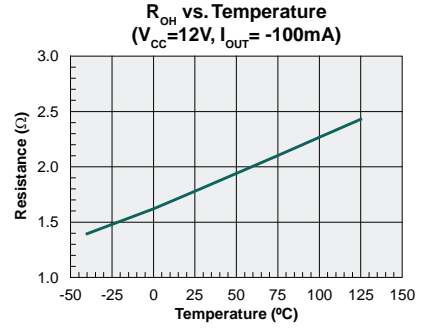
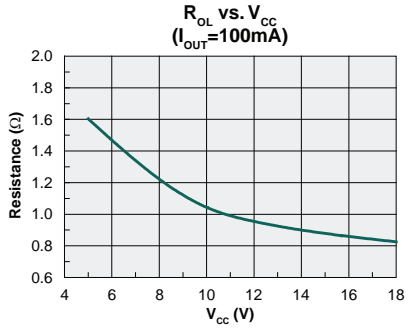
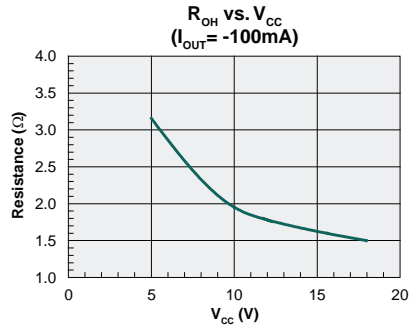

*Unless otherwise noted, data presented in these graphs is typical of device operation at 25°C.

3 Manufacturing Information

3.1 Moisture Sensitivity



All plastic encapsulated semiconductor packages are susceptible to moisture ingress. IXYS Integrated Circuits classifies its plastic encapsulated devices for moisture sensitivity according to the latest version of the joint industry standard, **IPC/JEDEC J-STD-020**, in force at the time of product evaluation. We test all of our products to the maximum conditions set forth in the standard, and guarantee proper operation of our devices when handled according to the limitations and information in that standard as well as to any limitations set forth in the information or standards referenced below.

Failure to adhere to the warnings or limitations as established by the listed specifications could result in reduced product performance, reduction of operable life, and/or reduction of overall reliability.

This product carries a **Moisture Sensitivity Level (MSL)** classification as shown below, and should be handled according to the requirements of the latest version of the joint industry standard **IPC/JEDEC J-STD-033**.

| Device | Moisture Sensitivity Level (MSL) Classification |
|---------|---|
| IX4310T | MSL 1 |

3.2 ESD Sensitivity



This product is **ESD Sensitive**, and should be handled according to the industry standard **JESD-625**.

3.3 Soldering Profile

Provided in the table below is the **IPC/JEDEC J-STD-020** Classification Temperature (T_C) and the maximum dwell time the body temperature of these surface mount devices may be ($T_C - 5$)°C or greater. The Classification Temperature sets the Maximum Body Temperature allowed for these devices during reflow soldering processes.

| Device | Classification Temperature (T_C) | Dwell Time (t_p) | Max Reflow Cycles |
|---------|--------------------------------------|----------------------|-------------------|
| IX4310T | 260°C | 30 seconds | 3 |

3.4 Board Wash

IXYS Integrated Circuits recommends the use of no-clean flux formulations. Board washing to reduce or remove flux residue following the solder reflow process is acceptable provided proper precautions are taken to prevent damage to the device. These precautions include but are not limited to: using a low pressure wash and providing a follow up bake cycle sufficient to remove any moisture trapped within the device due to the washing process. Due to the variability of the wash parameters used to clean the board, determination of the bake temperature and duration necessary to remove the moisture trapped within the package is the responsibility of the user (assembler). Cleaning or drying methods that employ ultrasonic energy may damage the device and should not be used. Additionally, the device must not be exposed to halide flux or solvents.



3.5 Mechanical Dimensions

3.5.1 IX4310T Package Dimensions

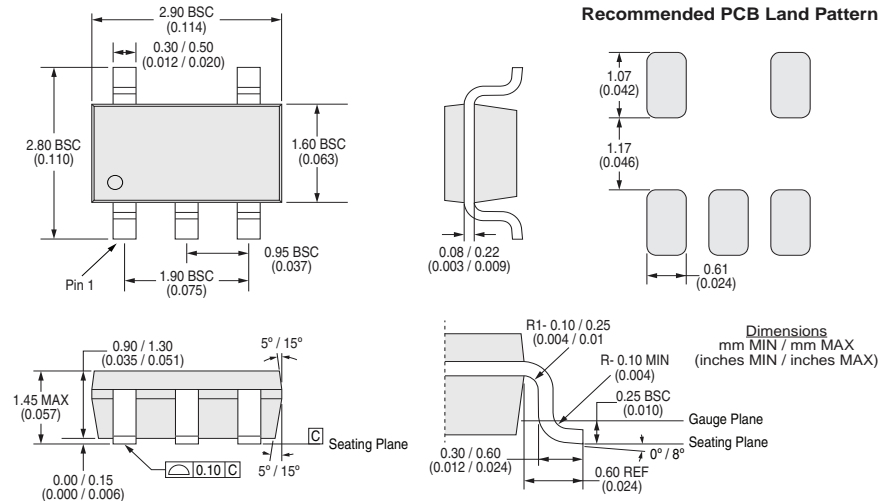

3.5.2 IX4310TTR Tape & Reel Dimensions

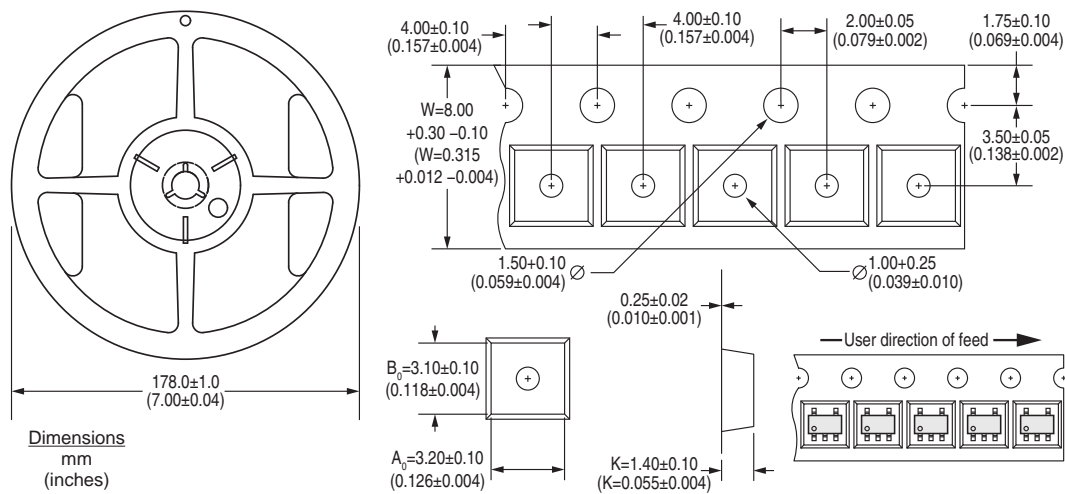

For additional information please visit our website at: <https://www.ixysic.com>