

1546310-8 ✓ ACTIVE

Buchanan

TE Internal #: 1546310-8

Barrier Strips, Dual Barrier, Non-Feed Through, Wire-to-Wire, 8 Position, 14.3mm [.563in] Centerline, 2 Row, 300V Voltage Rating, 22 – 10AWG Wire Size

[View on TE.com >](#)



Connectors > Terminal Blocks & Strips > Barrier Strips



Barrier Strip Style: **Dual Barrier**

Bottom Termination Type: **Non-Feed Through**

Connector System: **Wire-to-Wire**

Number of Positions: **8**

Centerline (Pitch): **14.3 mm [.563 in]**

Features

Product Type Features

Product Type	Barrier Strip
Block Style	Flat
Connector System	Wire-to-Wire
Connector & Contact Terminates To	Wire & Cable

Configuration Features

Number of Levels	1
Number of Positions	8
Number of Rows	2

Electrical Characteristics

Current Rating (Max)	30 A
Voltage Rating	300 V

Body Features

Color	Black
Barrier Strip Style	Dual Barrier

Contact Features

Terminal Plating Material	Tin
Terminal Material	Brass
Contact Current Rating (Max)	30 A



Termination Features

Bottom Termination Type	Non-Feed Through
-------------------------	------------------

Mechanical Attachment

Mounting Angle	Vertical
Screw Head Type	Combo Phil-Slot
Top Termination Type	Binding Combo Head
Mounting Insert	Without
Screw Plating Material	Nickel
Screw Material	Steel
Mounting Options	End Mounting Ears
Mounting Ears	With
Screw Size	8-32
Connector Mounting Type	Panel Mount

Housing Features

Housing Material	PBT
Centerline (Pitch)	14.3 mm[.563 in]

Dimensions

Length	140 mm[5.5 in]
Wire Size	.3 – 6 mm ²

Usage Conditions

Operating Temperature Range	-40 – 120 °C[-40 – 248 °F]
-----------------------------	----------------------------

Operation/Application

Circuit Application	Power
---------------------	-------

Industry Standards

UL Flammability Rating	UL 94V-0
------------------------	----------

Packaging Features

Packaging Quantity	50
Packaging Method	Carton

Other

Comment	Other options available upon request, consult our Product Information Center.
---------	---

Product Compliance

For compliance documentation, visit the product page on [TE.com](#)>

EU RoHS Directive 2011/65/EU	Compliant
EU ELV Directive 2000/53/EC	Compliant
China RoHS 2 Directive MIIT Order No 32, 2016	No Restricted Materials Above Threshold
EU REACH Regulation (EC) No. 1907/2006	Current ECHA Candidate List: JAN 2021 (211) Candidate List Declared Against: JAN 2021 (211) Does not contain REACH SVHC
Halogen Content	Not Low Halogen - contains Br or Cl > 900 ppm.
Solder Process Capability	Wave solder capable to 265°C

Product Compliance Disclaimer

This information is provided based on reasonable inquiry of our suppliers and represents our current actual knowledge based on the information they provided. This information is subject to change. The part numbers that TE has identified as EU RoHS compliant have a maximum concentration of 0.1% by weight in homogenous materials for lead, hexavalent chromium, mercury, PBB, PBDE, DBP, BBP, DEHP, DIBP, and 0.01% for cadmium, or qualify for an exemption to these limits as defined in the Annexes of Directive 2011/65/EU (RoHS2). Finished electrical and electronic equipment products will be CE marked as required by Directive 2011/65/EU. Components may not be CE marked. Additionally, the part numbers that TE has identified as EU ELV compliant have a maximum concentration of 0.1% by weight in homogenous materials for lead, hexavalent chromium, and mercury, and 0.01% for cadmium, or qualify for an exemption to these limits as defined in the Annexes of Directive 2000/53/EC (ELV). Regarding the REACH Regulation, the information TE provides on SVHC in articles for this part number is based on the latest European Chemicals Agency (ECHA) 'Guidance on requirements for substances in articles' posted at this URL: <https://echa.europa.eu/guidance-documents/guidance-on-reach>

Compatible Parts



TE Part # 1546311-8
8P .563" DR BARRIER,W/WASHER

Customers Also Bought

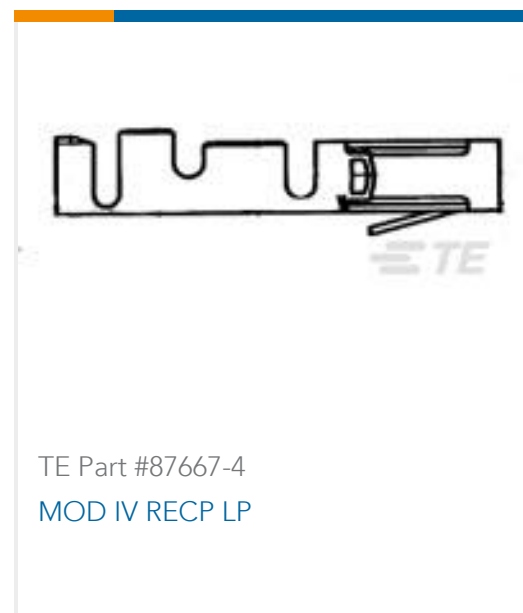

Documents

Product Drawings

[8P .563" DR BARRIER STRIP](#)

English

CAD Files

[3D PDF](#)

3D

Customer View Model

[ENG_CVM_CVM_1546310-8_Y_c-1546310-8-y.2d_dxf.zip](#)

English

Customer View Model

[ENG_CVM_CVM_1546310-8_Y_c-1546310-8-y.3d_igs.zip](#)

English

Customer View Model

[ENG_CVM_CVM_1546310-8_Y_c-1546310-8-y.3d_stp.zip](#)

English

By downloading the CAD file I accept and agree to the [Terms and Conditions](#) of use.

Datasheets & Catalog Pages



BUCHANAN TERMINAL BLOCKS CATALOG - BARRIER STRIPS

English

1-1773458-2_BARRIER_STRIPS_QUICK_REFERENCE_GUIDE

English

Product Environmental Compliance

Product Compliance

English

Product Compliance

English