

**Food & Beverage Hygienic, TPE  
Connection Cable  
WKH4.5-5/TFG**

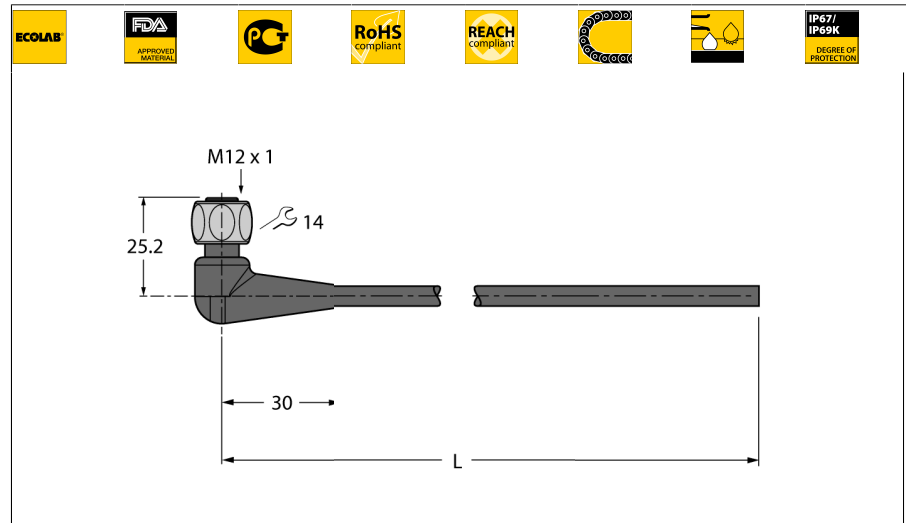

- M12 female connector, angled, 5-pin
- Stainless steel coupling nut/screw
- Sheath material: TPE-O
- Sheath color: light gray RAL 7035
- Qualified for drag chain use
- Resistant to chemicals and microbes
- Weatherproof
- Resistant to hydrolysis acc. to DIN EN 60068-2-78
- Flexible at low temperatures
- Free from silicone and PVC
- Halogen-free acc. to DIN EN 50267-2-1, IEC 60754-1, VDE 0482-267-2-1
- Approvals: Gost, Ecolab, FDA
- RoHS and REACH compliant
- Protection classes IP67, IP69K
- Cable length: 5.0 m

|                         |              |
|-------------------------|--------------|
| <b>Type designation</b> | WKH4.5-5/TFG |
| Ident no.               | 6933549      |

|                         |   |
|-------------------------|---|
| <b>Connector A side</b> | Female connector, M12 ⌀ 1, Angled                       |
| Number of pins          | 5   |
| Contacts                | Brass, CuZn, Gold-plated                                |
| Contact carriers        | Plastic, PP, Gray                                       |
| Grip                    | Plastic, PP, Gray                                       |
| Coupling nut/screw      | Stainless steel, V4A                                    |
| Seal                    | Plastic, FPM/FKM  |
| Protection class        | IP67, IP69K, A + B side screwed together                |
| Mechanical lifespan     | > 100 Mating cycles                                     |
| Pollution degree        | 3   |
| Tightening torque       | 0.8 ... 1 Nm<br>(observe max. torque of counter piece!) |

|                        |                       |
|------------------------|-----------------------|
| <b>General data</b>    |                       |
| Cable diameter         | 5 ± 0.15mm            |
| Cable length           | 5 m                   |
| Cable quality          | TPE-O                 |
| Cable color            | Gray                  |
| Core insulation        | TPE-E                 |
| Core colors            | BN, BU, BK, WH, GY    |
| Core cross-section     | 5x0.34mm <sup>2</sup> |
| Arrangement of strands | 42x0.1 mm             |

|                                      |            |
|--------------------------------------|------------|
| <b>Electrical features at +20 °C</b> |            |
| Current                              | 4 A        |
| Rated voltage                        | 60 V       |
| Nom. Inductance                      | 0.73 mH/km |
| Nom. capacitance                     | 82 pF/m    |
| Test voltage                         | 2000 V     |

**Cable Cross-section**

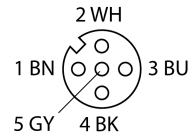
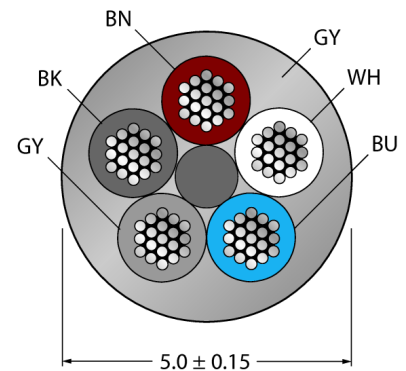

**Circuit Diagram**

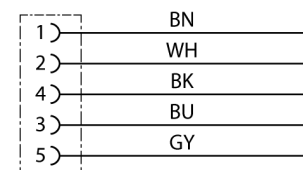

# Food & Beverage Hygienic, TPE Connection Cable WKH4.5-5/TFG

**TURCK**

Industrial  
Automation

---

## Mechanical and chemical properties

|                                    |                              |
|------------------------------------|------------------------------|
| Max. tensile strength (static)     | ≤ 50 N/mm <sup>2</sup>       |
| Max. tensile strength (dynamic)    | ≤ 20 N/mm <sup>2</sup>       |
| Bending cycles                     | > 4 mil.                     |
| Bending radius (stationary laying) | > 5 x Ø                      |
| Bending radius (flexible use)      | > 10 x Ø                     |
| Admissible acceleration            | max. 5 m/s <sup>2</sup>      |
| Admissible travel path, horizontal | 5 m (at 5 m/s <sup>2</sup> ) |
| Admissible travel path, vertical   | 2 m (at 5 m/s <sup>2</sup> ) |
| Admissible traversing speed        | 3 m/s                        |
| Torsional stress                   | ± 180 °/m                    |
| Ambient temperature                |                              |
| Stationary                         | -40...+105°C                 |
| In motion                          | -25...+105°C                 |
| Drag chain operation               | -25...+60°C                  |