

MC21605FA6WE-FPTLW	2 x 16	5mm Character Height	LCD Module
<b>Specification</b>			
Version: 1		Date: 29/01/2021	
<b>Revision</b>			
1	27/01/2021	First Issue	

Display Features			
Character Count		2 x 16	
Appearance		Black on White	
Logic Voltage		5V	
Interface		Parallel	
Font Set		English / European	
Display Mode		Transflective	
Character Height		4.69mm	
LC Type		FSTN	
Module Size		59.00 x 29.00 x 5.50 mm	
Operating Temperature		-20°C ~ +70°C	
Construction		COB	Box Quantity
LED Backlight		White	Weight / Display
			---
			---



\* - For full design functionality, please use this specification in conjunction with the ST7066U specification. (Provided Separately)

Display Accessories	
Part Number	Description
MCCMDB-16SIL	LCD Interconnect board, can be driven from either a PC or a single Board computer with a USB output.
MCCBL1A16SLIP-16DILS-150	16 Way, Single in-line to Dual In-line connector Cable.
MCCBL1A16SLIP-16SILS-150	16 Way, Single in-line to Single In-line connector Cable.
MDIB-CC1	The MDIB-CC1 is a interconnect board for standard pitch pinouts to fine pitch wires. Ideal for prototyping of TFT and COG LCDs.

Optional Variants		
Fonts	Appearances	Voltage
English/Japanese English/Cyrillic	Black on Yellow/ Green White on Blue Black on RGB	3V 3.3V



## 1. FUNCTIONS & FEATURES

- Viewing Direction : 6 O'clock
- Driving Scheme : 1/16 Duty Cycle, 1/5 Bias
- Power Supply Voltage : 5.0V
- VLCD : 3.71V
- Display contents : 16 Characters x 2 line
- Internal Memory : CGROM (13200bits )  
: CGRAM (64 x 8bits)  
: DDRAM (80 x 8 bits for Digits)
- CGROM : CGROM of the ST7066U-0B
- Easy Interface with a 4-bit or 8-bit MPU
- RoHS Compliant

## 2. MECHANICAL SPECIFICATIONS

- Module Size : 59(L) x 29(W) x 5.5(H)mm
- Viewing area : 52(L) x 15 (W) mm
- Active area : 46.7(L) x 9.84(W) mm
- Dot Size : 0.45 (L) x 0.54 (W) mm
- Dot Gap : 0.50mm

design • manufacture • supply



# EXTERNAL DIMENSIONS

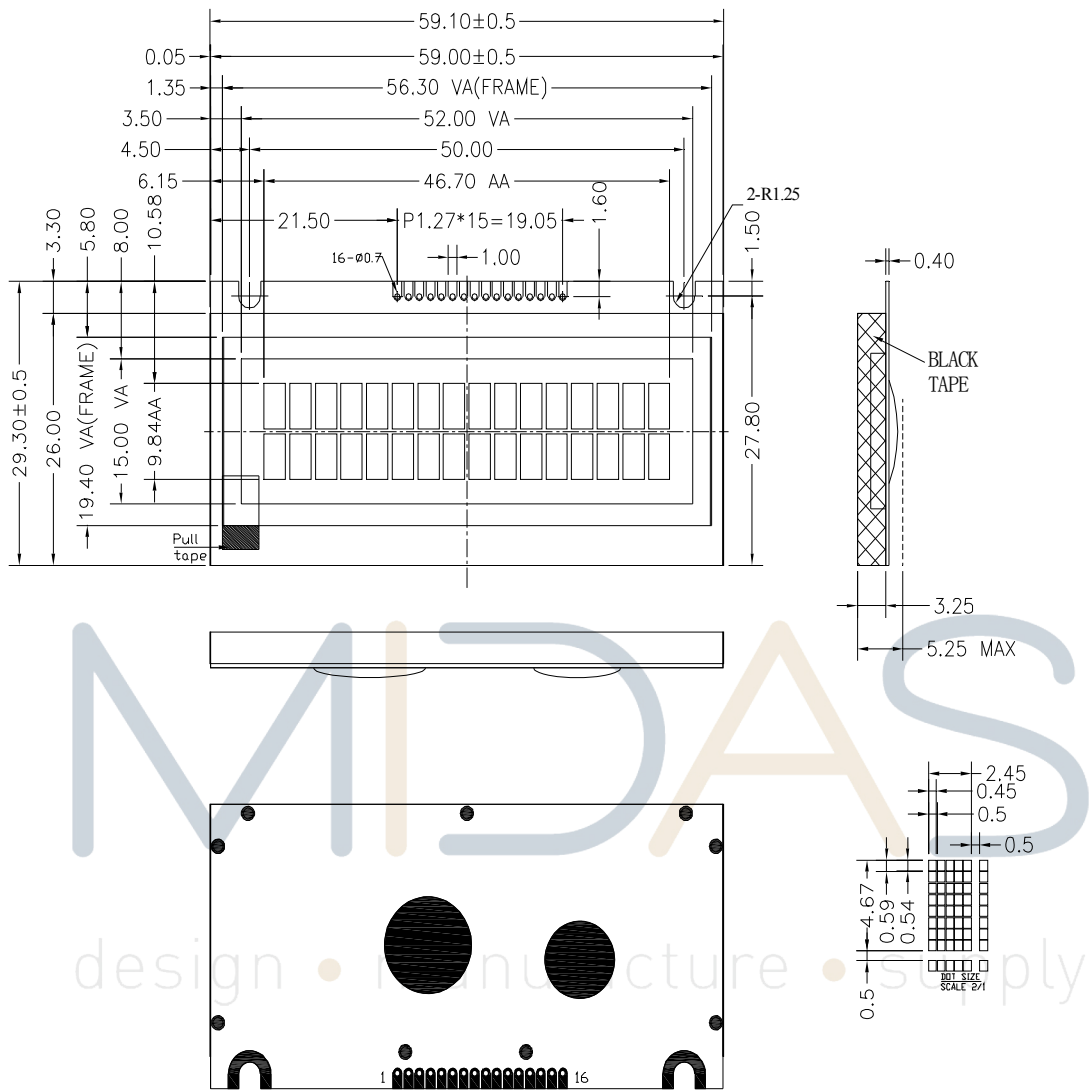

- Remarks:
1. Unmarked tolerance is  $\pm 0.3$
  2. All materials comply with RoHs



## BLOCK DIAGRAM

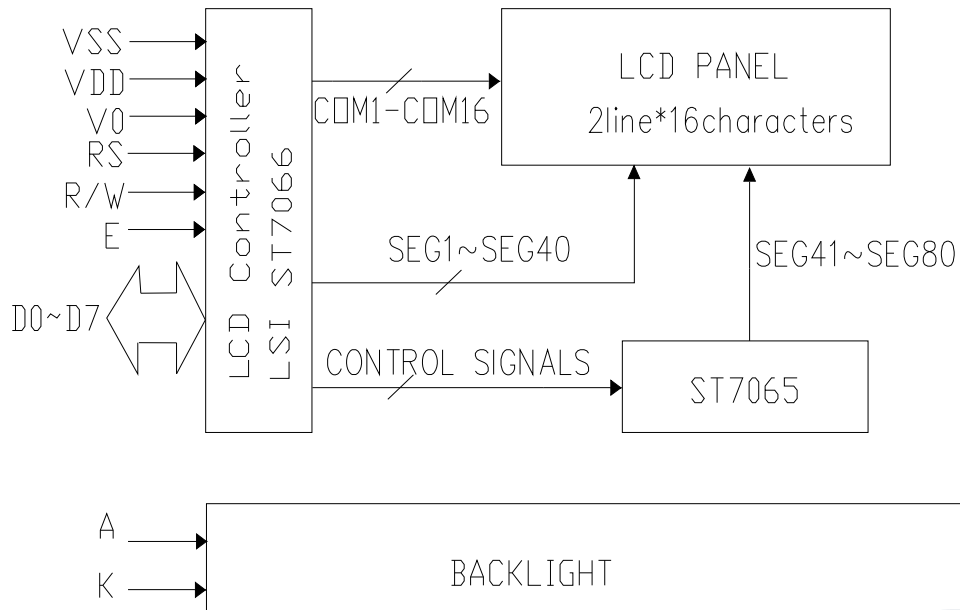

## PIN ASSIGNMENT

Pin No.	Symbol	Function
1	VLED(-)	Power supply for B/L(-)
2	VSS	Ground
3	VDD	Supply Voltage for logic
4	V0	Operating voltage for LCD
5	RS	H:DATA,L:instruction code
6	R/W	H:Read(Module→MPU) L: (MPU→Module)
7	E	Chip enable signal
8	DB0	Date bus line
9	DB1	
10	DB2	
11	DB3	
12	DB4	
13	DB5	
14	DB6	
15	DB7	
16	A	LED+

# BACKLIGHT CHARACTERISTICS

## Electrical-Optical Characteristics

Item	Symbol	MIN.	TYP.	MAX.	Unit	Condition
Forward Curret(B00/03)	If	—	2	—	mA	Vf=3.2 V
Forward Curret(B01)	If	—	5*2	15*2	mA	
Colour Coordinate	x	0.23	0.26	0.33		
	y	0.23	0.26	0.33		
Uniformity	Avg		70		%	
Luminance(B00/03)	Lv		150		cd/m <sup>2</sup>	
Luminance(B01)	Lv	300	450	—	cd/m <sup>2</sup>	

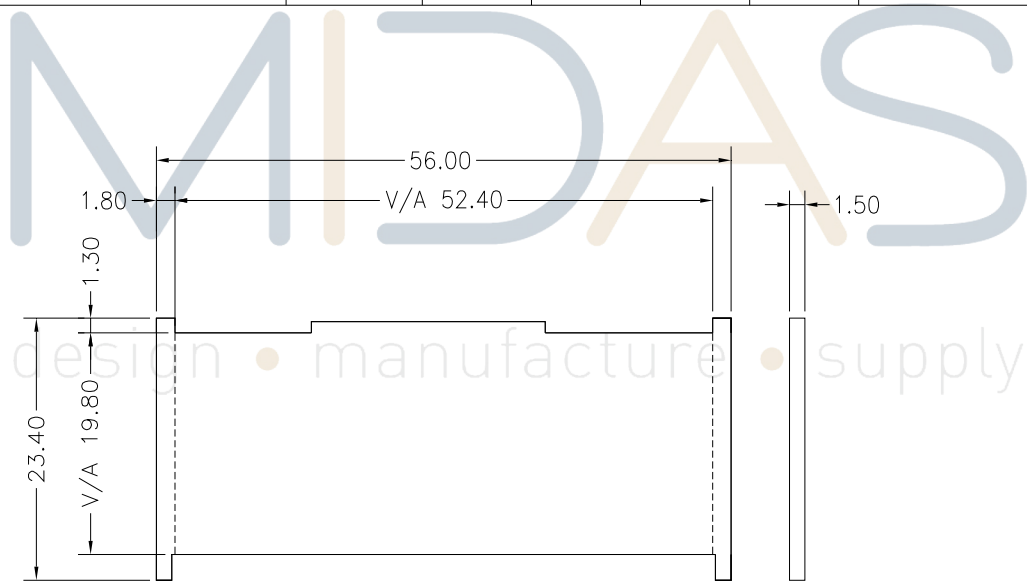

### Circuit Diagram

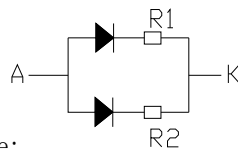

Note:

MC21605FA6WE-FPTLW:R1=R2=750Ω

REMARKS:

- 1, UNMARKED TOLERANCE IS  $\pm 0.3$ ,
- 2, COLOR: WHITE,
- 3, THE MATERIAL COMPLY WITH ROHS.
- 4, LED ON THE MODULE PCB



## MAXIMUM ABSOLUTE POWER RATINGS

Item	Symbol	Standard value	Unit
Supply voltage for logic	$V_{DD} - V_{SS}$	-0.3~+7.0	V
Supply voltage for LCD	$V_{LCD} - V_{SS}$	-0.3-13	V
Input voltage	$V_{IN}$	$V_{SS} \sim V_{DD}$	V
Operating temperature	$T_{opr}$	-20~+70	°C
Storage temperature	$T_{stg}$	-30~+80	°C

## DC CHARACTERISTICS

Item	Symbol	Standard Value			Test Condition	Unit
		MIN	TYP	MAX		
Supply Voltage For Logic	$V_{DD} - V_{SS}$	—	5.0	—	—	V
Supply Voltage For LCD *Note	$V_{DD} - V_0$	—	—	—	$T_a = -20^\circ\text{C}$	V
		—	3.71	—	$T_a = 25^\circ\text{C}$	V
		—	—	—	$T_a = 70^\circ\text{C}$	V
Input High Volt.	$V_{IH}$	$0.7 V_{DD}$	—	$V_{DD}$	—	V
Input Low Volt.	$V_{IL}$	$V_{SS}$	—	0.6	—	V
Output High Volt.	$V_{OH}$	3.9	—	$V_{DD}$	—	V
Output Low Volt.	$V_{OL}$	0	—	0.4	—	V
Supply Current	$I_{DD}$	1.0	1.2	1.5	$V_{DD} = 5.0\text{V}$	mA

\* Note: Please design the VOP adjustment circuit on customer's main board

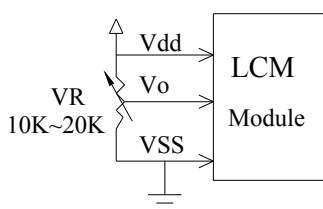

# AC CHARACTERISTICS

## 1. Write mode

(VDD=5.0V, Ta=-10~+60°C)

Characteristic	Symbol	Min	Type	Max	Unit	Test PIN
Enable Cycle Time	$t_C$	1200	---	---	ns	E
Enable Pulse Time	$T_{PW}$	140	---	---	ns	E
Enable Rise/Fall Time	$T_R, T_F$	---	---	25	ns	E
Address Set-up Time	$T_{AS}$	0	---	---	ns	RW,RS,E
Address Hold Time	$T_{AH}$	10	---	---	ns	RW,RS,E
Data Set-up Time	$T_{DSW}$	40	---	---	ns	DB0~DB7
Data Hold Time	$T_H$	10	---	---	ns	DB0~DB7

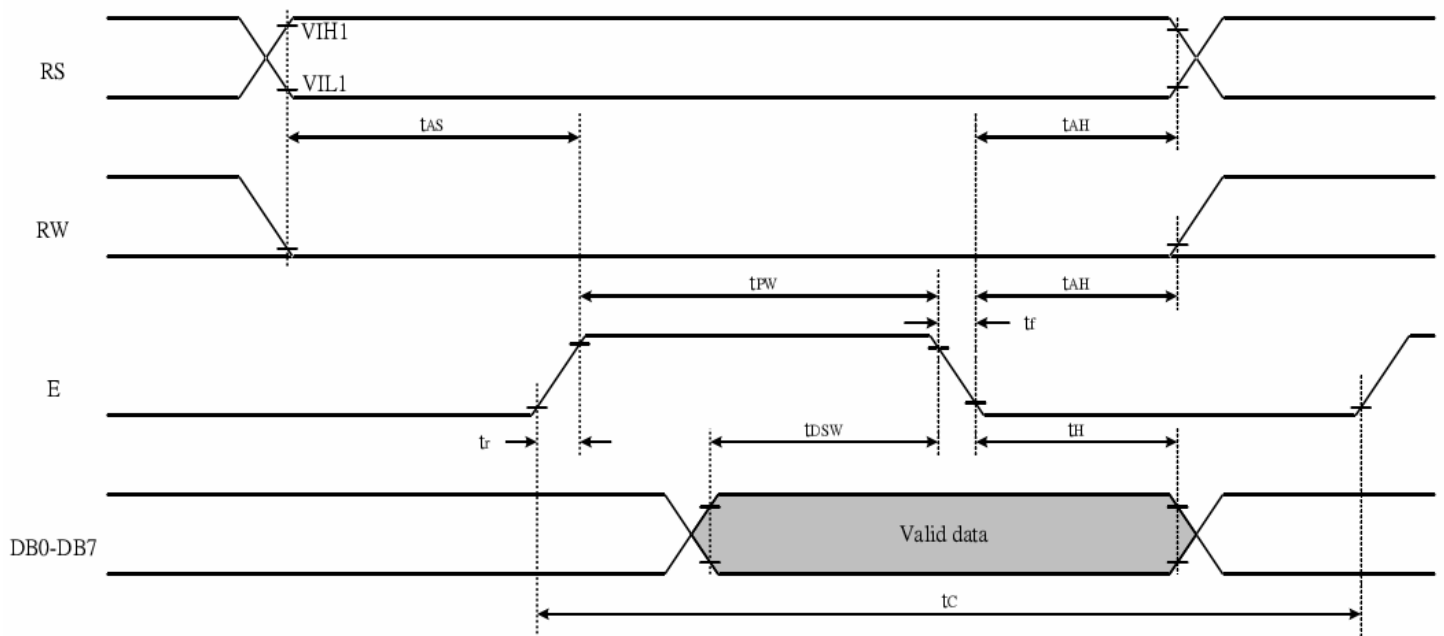

## 2. Read Mode

(VDD=5.0V, Ta=-10~+60°C)

Characteristic	Symbol	Min	Type	Max	Unit	Test PIN
Enable Cycle Time	$t_C$	1200	---	---	ns	E
Enable Pulse Time	$T_{PW}$	140	---	---	ns	E
Enable Rise/Fall Time	$T_R, T_F$	---	---	25	ns	E
Address Set-up Time	$T_{AS}$	0	---	---	ns	RW,RS,E
Address Hold Time	$T_{AH}$	10	---	---	ns	RW,RS,E
Data Set-up Time	$T_{DDR}$	---	---	100	ns	DB0~DB7
Data Hold Time	$T_H$	10	---	---	ns	DB0~DB7

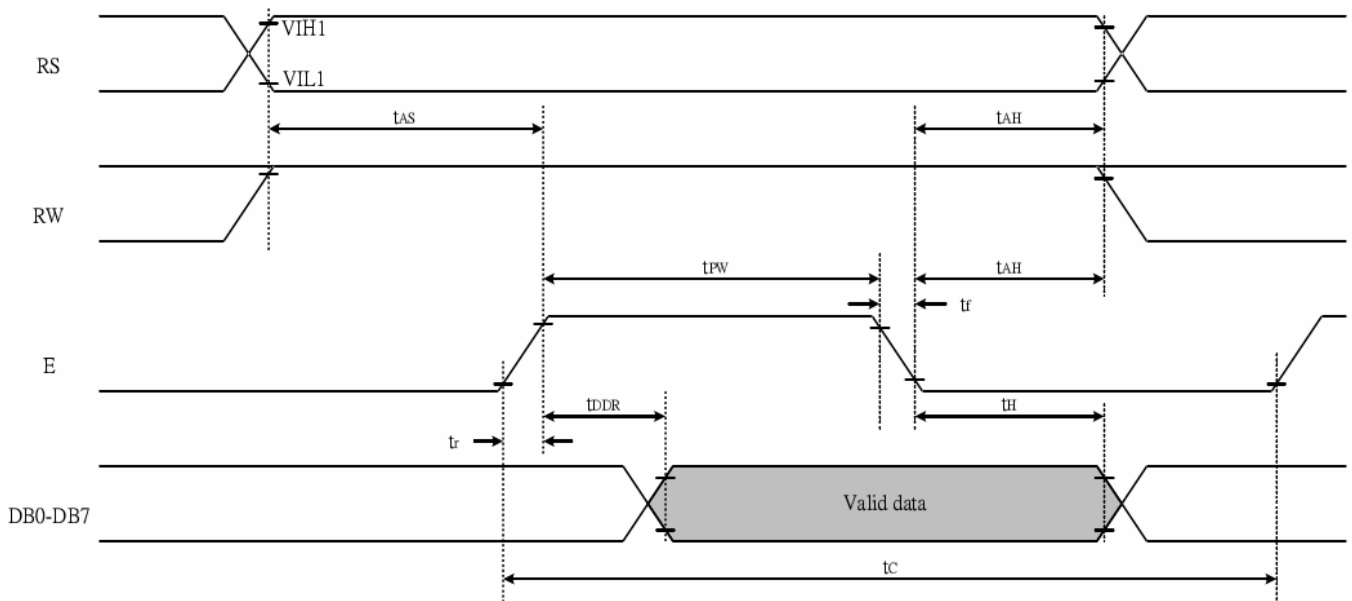



# STANDARD CHARACTER PATTERN (ST7066U-0B)

NO.7066-0B

b7-b4 b3-b0	0000	0001	0010	0011	0100	0101	0110	0111	1000	1001	1010	1011	1100	1101	1110	1111
0000	CG RAM (1)	±	∅	⊙	⊖	⊗	⊘	⊙	⊖	⊗	⊘	⊙	⊖	⊗	⊘	⊙
0001	(2)	≡	!	1	A	Q	a	9	0	æ	ı	ı	J	†	y	o
0010	(3)	7	"	2	B	R	b	r	é	ē	ó	°	°	§	δ	χ
0011	(4)	Δ	#	3	C	S	c	s	á	ò	ú	ı	ı	¶	¶	ψ
0100	(5)	γ	\$	4	D	T	d	t	ä	ö	ç	ı	ı	¶	¶	ω
0101	(6)	γ	%	5	E	U	e	u	à	ó	ē	ı	ı	Δ	η	¶
0110	(7)	γ	&	6	F	V	f	v	à	ó	¶	ı	ı	⊙	⊙	¶
0111	(8)	γ	'	7	G	W	g	w	ó	ú	ı	ı	ı	Δ	ı	¶
1000	(1)	γ	(	8	H	X	h	x	è	9	ı	ı	ı	Δ	ı	¶
1001	(2)	γ	)	9	I	Y	i	y	è	ı	ı	ı	ı	Δ	ı	¶
1010	(3)	⊗	*	*	J	Z	j	z	è	ı	ı	ı	ı	Δ	ı	¶
1011	(4)	J	+	;	K	L	k	l	ı	ı	ı	ı	ı	Δ	ı	¶
1100	(5)	=	,	<	L	\	ı	ı	ı	ı	ı	ı	ı	Δ	ı	¶
1101	(6)	ı	-	=	M	I	m	ı	ı	ı	ı	ı	ı	Δ	ı	¶
1110	(7)	ı	.	>	N	^	n	^	ı	ı	ı	ı	ı	Δ	ı	¶
1111	(8)	ı	/	?	O	_	o	_	ı	ı	ı	ı	ı	Δ	ı	¶



## INSTRUCTION TABLE

Command	RS	R/W	DB7	DB6	DB5	DB4	DB3	DB2	DB1	DB0	Execution time (fosc=270KHz)	Remark
Clear Display	0	0	0	0	0	0	0	0	0	1	1.52ms	Write "20H" to DDRAM. And set DDRAM address to "00H" from AC
Return home	0	0	0	0	0	0	0	0	1	x	1.52ms	Set DDRAM address to "00H" from AC and return cursor to its original position if shifted. The contents of DDRAM are not changed.
Entry mode Set	0	0	0	0	0	0	0	1	I/D	S	37us	Sets cursor move direction and specifies display shift. These operations are performed during data write and read.
Display on/off control	0	0	0	0	0	0	1	D	C	B	37us	D=1: entire display on C=1: cursor on B=1: cursor position on
Cursor or Display Shift	0	0	0	0	0	1	S/C	R/L	x	x	37us	Set cursor moving and display shift control bit, and the direction, without changing DDRAM data.
function Set	0	0	0	0	1	DL	N	F	x	x	37us	DL: interface data is 8/4 bits N: number of line is 2/1 F: font size is 5x11/5x8
Set CGRAM address	0	0	0	1	AC5	AC4	AC3	AC2	AC1	AC0	37us	Set CGRAM address in address counter
Set DDRAM address	0	0	1	AC6	AC5	AC4	AC3	AC2	AC1	AC0	37us	Set DDRAM address in address counter
Read busy flag& address	0	1	BF	AC6	AC5	AC4	AC3	AC2	AC1	AC0	0us	Whether during internal operation or not can be known by reading BF. The contents of address counter can also be read.
Write data to RAM	1	0	D7	D6	D5	D4	D3	D2	D1	D0	37us	Write data into internal RAM (DDRAM/CGRAM)
Read data from RAM	1	1	D7	D6	D5	D4	D3	D2	D1	D0	37us	Read data from internal RAM (DDRAM / CGRAM)

### Note:

Be sure the ST7066U is not in the busy state (BF=00) before sending an instruction from the MPU to the ST7066U. If an instruction is sent without checking the busy flag, the time between the first instruction and next instruction will take much longer than the instruction time itself. Refer to instruction table for the list of each instruction execution time.



# RESET FUNCTION

8-bit Interface ( $f_{osc}=270\text{KHz}$ )

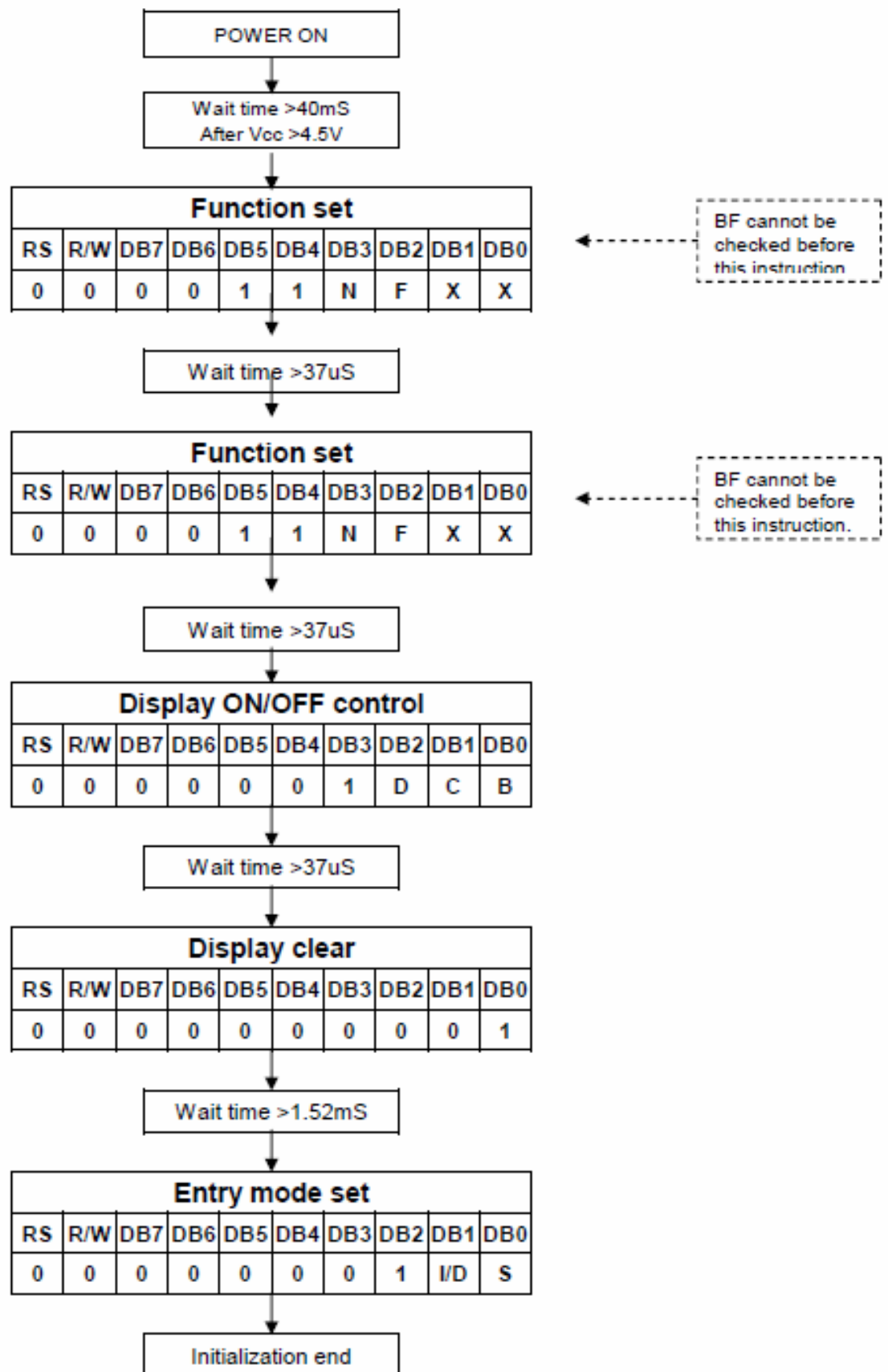

4-bit Interface (fosc=270KHz)

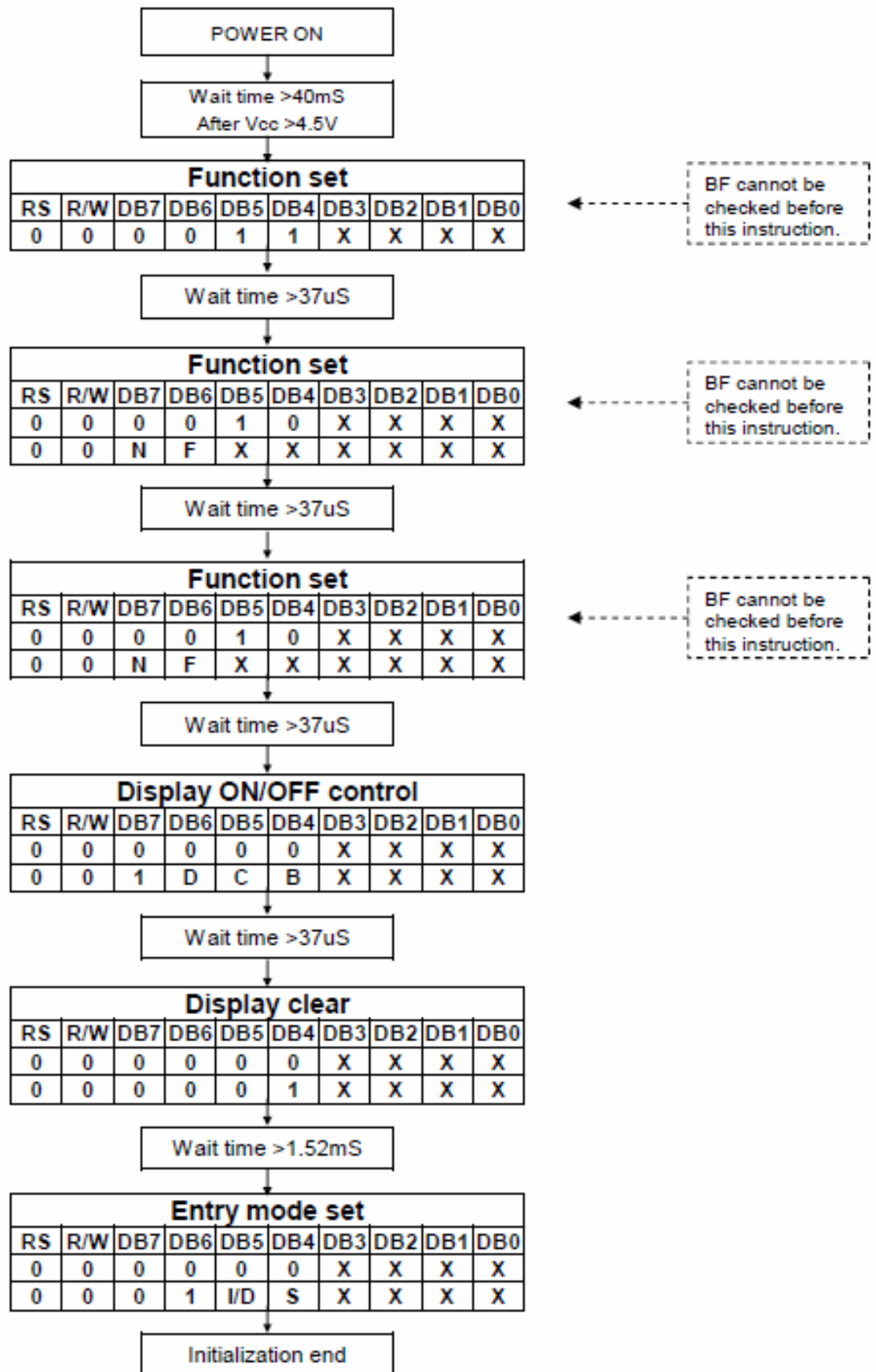

# ELECTRO-OPTICAL DEFINITION

## Optical Characteristics

Item	Symbol	Description	Condition	Min	Typ	Max	Unt
Operating Voltage of LCD	$V_{LCD}$	---	$T_a=+25^{\circ}C$	---	3.71	---	V
Response time	$T_r$	Rise	$25^{\circ}C$	150	200	---	ms
	$T_f$	Fall	$25^{\circ}C$	150	200	---	ms
Contrast	$Cr$		$25^{\circ}C$	---	3	---	
Viewing angle	$\theta$	12 o'clock axis	$Cr \geq 2.0$	30	35	---	deg
		6 o'clock axis		35	40	---	deg
		3 o'clock axis		30	35	---	deg
		9 o'clock axis		30	35	---	deg

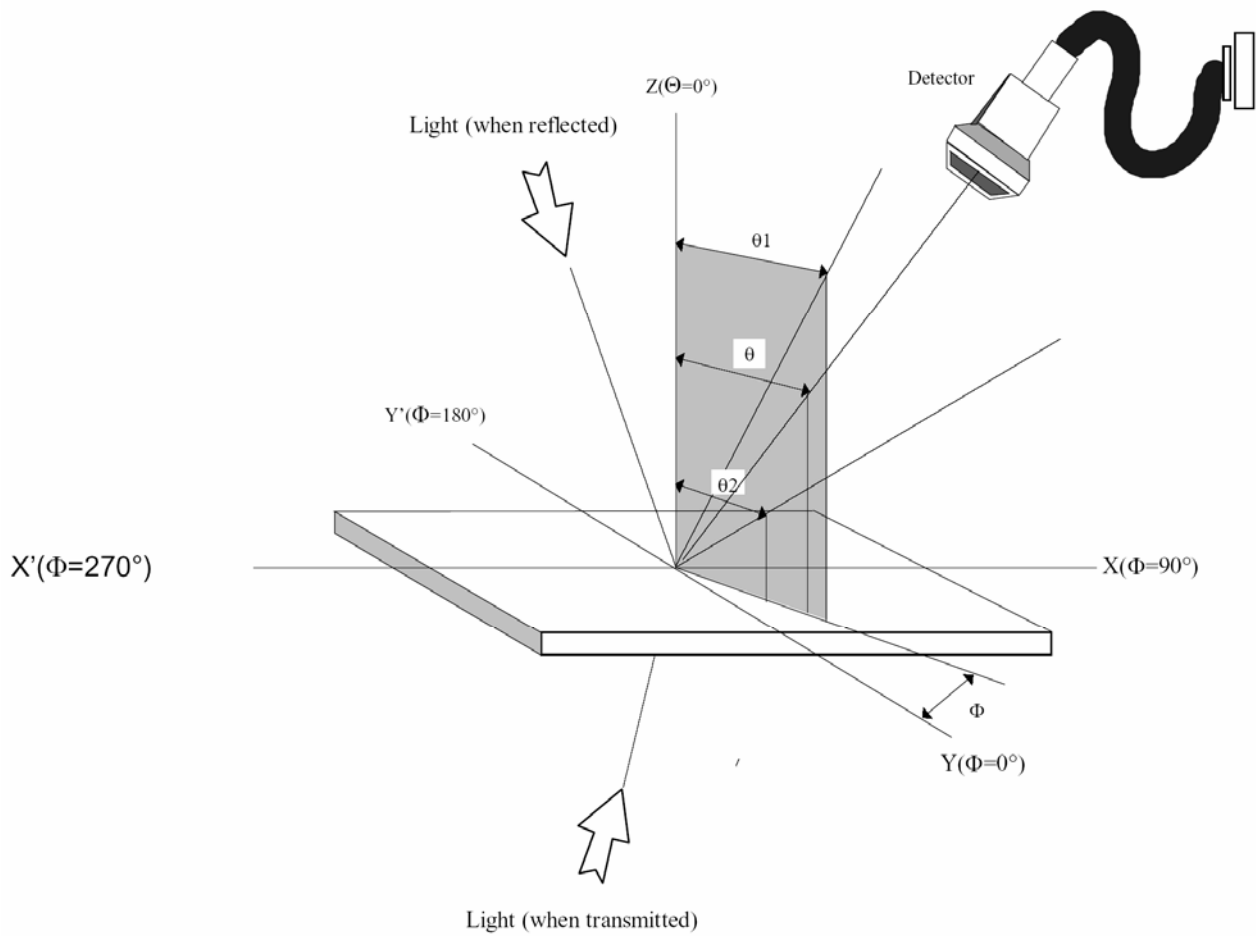

Definition of contrast  $Cr. = \frac{B_2}{B_1} = \frac{\text{Bright curve of not selected segment}}{\text{Bright curve of selected segment}}$

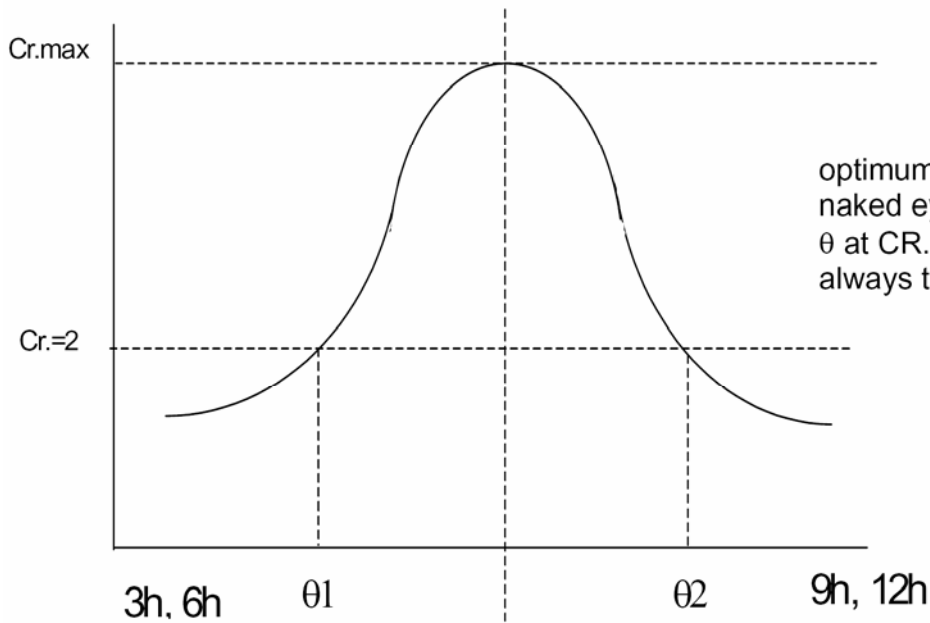
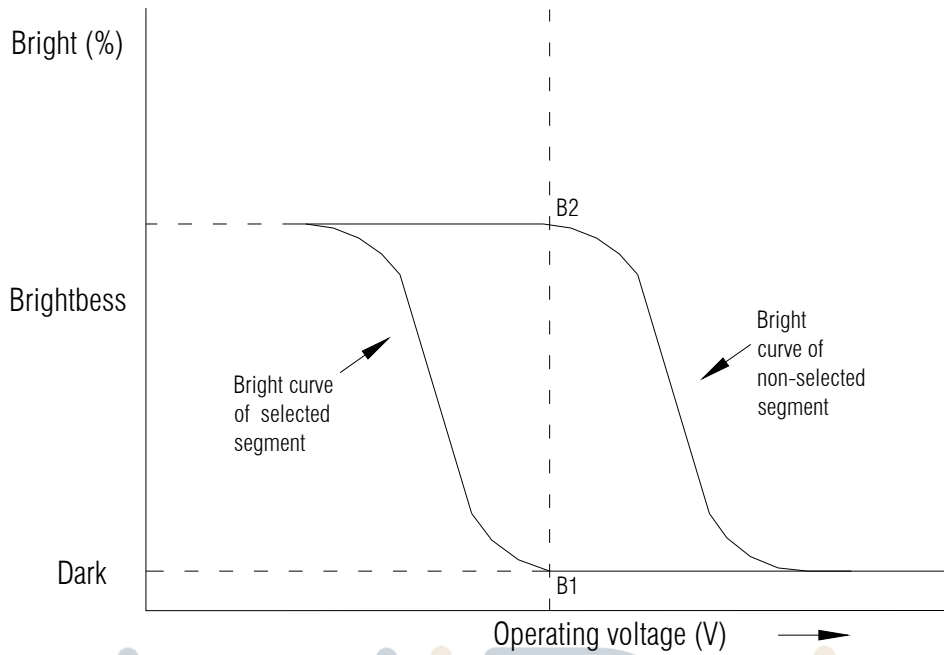

# LCD ARTWORK

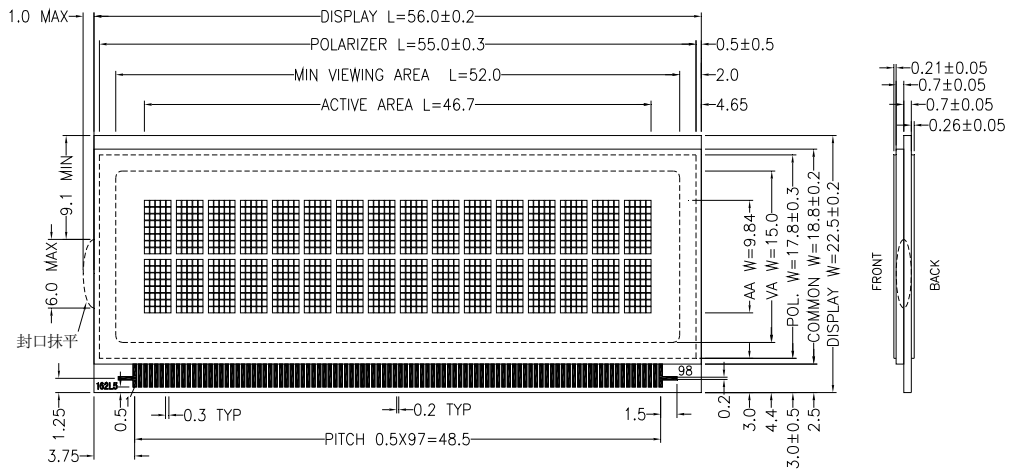

UNLESS OTHERWISE SPECIFIED  
DIMENSIONS ARE IN MM  
TOLERANCES:  $\pm 0.2$ MM



( 1 : 1 )

# MIDAS

design • manufacture • supply



# LABELLING

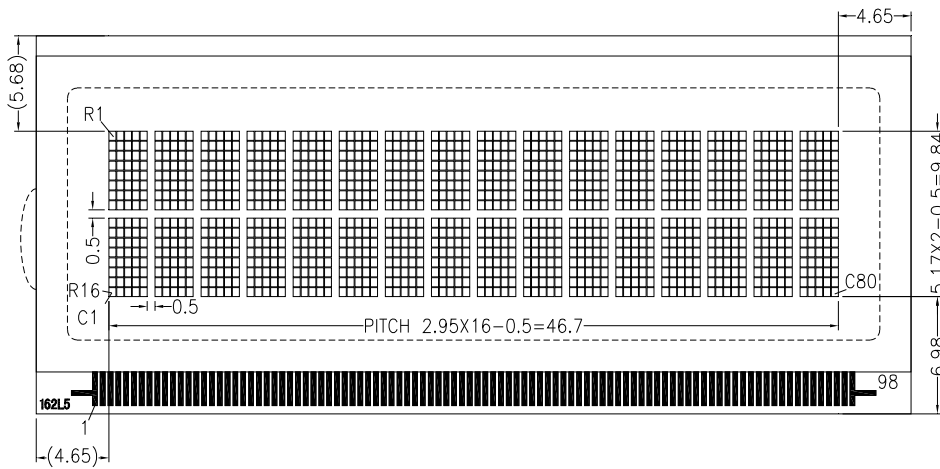

UNLESS OTHERWISE SPECIFIED  
 DIMENSIONS ARE IN MM  
 TOLERANCES: ±0.2MM



## PAD CONFIGURATION & GRAPHIC DIMENSION

design manufacture supply

PAD_NO.	PAD_CONFIGURATION
1	ESD
2	COM1[R1(C1-C80)]
9	COM8[R8(C1-C80)]
10	SEG1[C1(R1-R16)]
89	SEG80[C80(R1-R16)]
90	COM16[R16(C1-C80)]
97	COM9[R9(C1-C80)]
98	ESD

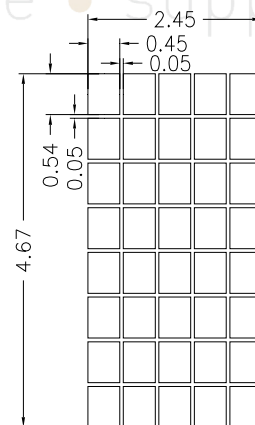

UNLESS OTHERWISE SPECIFIED  
 DIMENSIONS ARE IN MM  
 TOLERANCES: ±0.1MM





# SEG & COM LAYOUT

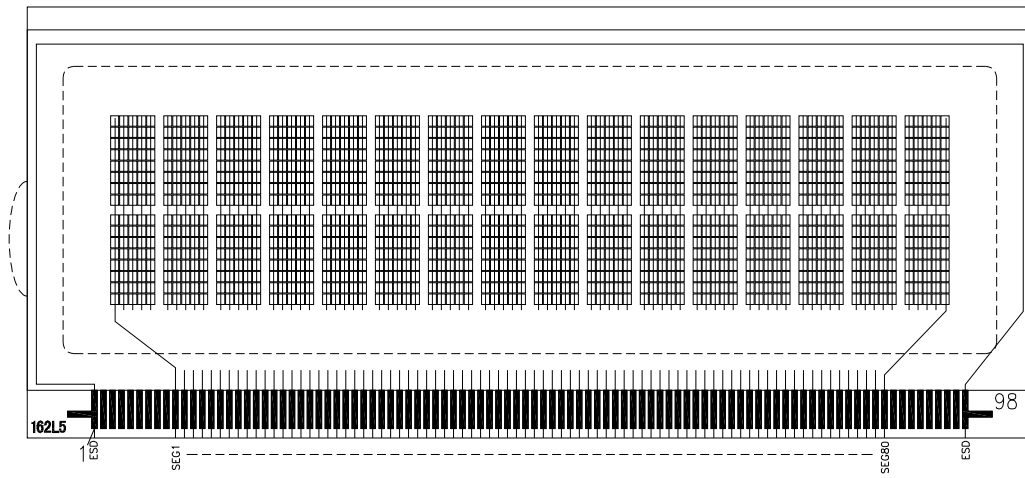

SEG LAYOUT

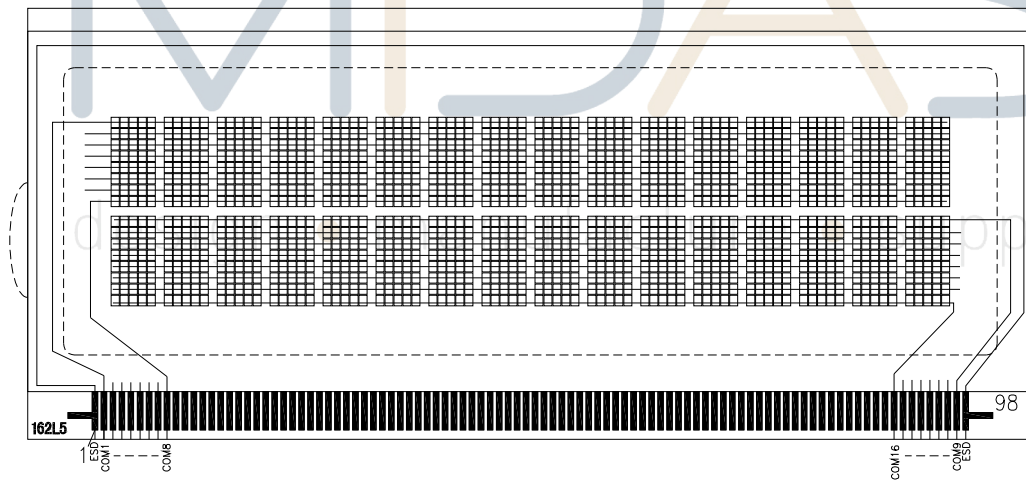

COM LAYOUT



## THE MODULE ACCEPT QUALITY LEVEL (AQL)

1. AQL standard value: Critical defect =0.1, Major defect=0.65; Minor defect =2.5.

### RELIABILITY TEST

Operating life time: 50,000 hours

(at room temperature without direct irradiation of sunlight)

Reliability characteristics shall meet following requirements.

Tests Item	Condition
High temperature storage	+80°C x 96HRS (Without Polarizer)
Low temperature storage	-30°C x 4HRS
High temperature operation	+70°C x 96HRS
Low temperature operation	-20°C x 4HRS
High temperature, High humidity	+60°C x 95%RH x 96HRS (Without Polarizer)
Thermal shock	-20°C x 30min → 25°C x 10s → +70°C x 30 min x 5 cycles
Vibration test	Frequency x Swing x Time 40Hz x 4mm x 4hrs
Drop test	Drop height*Times 1.0m * 6times

design • manufacture • supply

