

# ROTARY ACTUATORS SERIES R1, Ø 32-100 mm

Rack-type rotary cylinders in various configurations:

- Configuration with standard magnet
- Version with male pinion or female hole
- Mechanical stroke adjustment
- Special configurations on request

The central body has ISO bore holes for wall fixing using ISO pin and/or flange fittings.

We always suggest to use flow microregulators. During the setup of the actuator, start with CLOSE flow microregulators, and open gradually till the achievement of the required speed.



TECHNICAL DATA		32	40	50	63	80	100
Gaskets		NBR					
Operating pressure	P	10 bar (1 MPa - 145 psi)					
Temperature range	°C	-10 to +70					
Fluid		Filtered lubricated or unlubricated air. Lubrication, if used, must be continuous.					
Bores	mm	Ø 32 ; Ø 40 ; Ø 50 ; Ø 63 ; Ø 80 ; Ø 100					
Rotation angle		90°; 180°; 270°; 360°					
Type of construction		Extruded profile					
Configuration		Magnetic standard cushioned					
Axial load	N	2500	2800	4500	5600	8500	12200
Max. moment (6 bar - 0.6 Mpa)	MF (Nm)	4.5	12.5	16	32	70	120

NB: The product is supplied with negative end-of-stroke piston (in the proximity of head A).

The first cycle involves movement of the piston (towards head B) with consequent anti-clockwise rotation of the pinion.

#### ACTUAL ROTATION ANGLE

- Cylinders without regulation of the rotation angle: the manufacturing tolerance is  $-1^{\circ} +4^{\circ}$  compared to the nominal value

- Cylinders with regulation of the rotation angle: the possible regulation counts  $\pm 3^{\circ}$ .

#### COMPONENTS

- ① ADJUSTING SCREW: steel
- ② HEAD GASKET: NBR
- ③ RACK BUSHING: self-lubricating sintered bronze
- ④ PINION: C40 chromed steel
- ⑤ CENTRAL BODY: anodised aluminium
- ⑥ BALL BEARING
- ⑦ JACKET: aluminium
- ⑧ PISTON GASKET: NBR
- ⑨ PISTON: aluminium
- ⑩ HEAD: die cast aluminium
- ⑪ NEEDLE: OT 58 brass

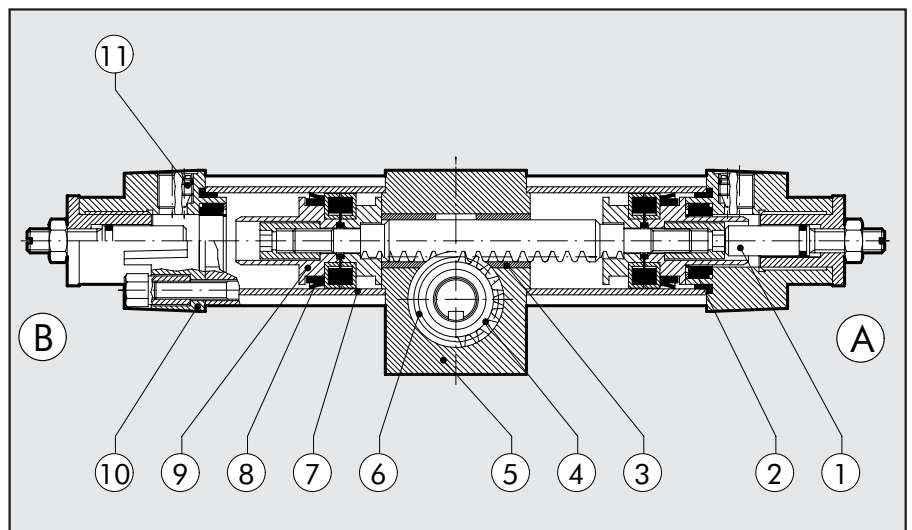

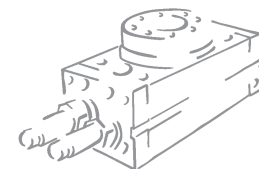

## DIMENSIONS OF ROTARY CYLINDER Ø 32-100

1

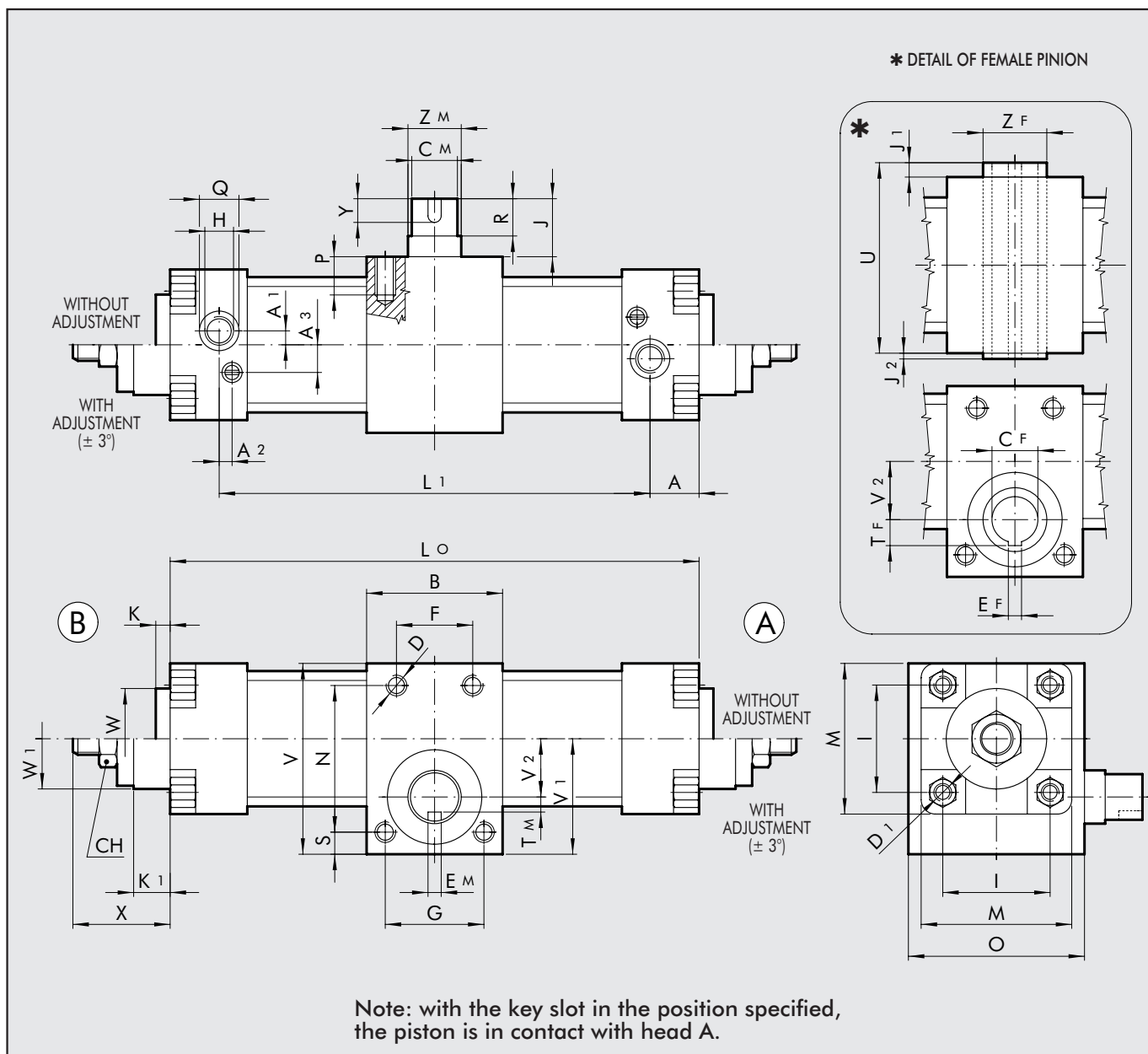

Ø	A	A <sub>1</sub>	A <sub>2</sub>	A <sub>3</sub>	B	CMh8	CF	D	D <sub>1</sub>	EM	EF	F	G	H	I	J	J <sub>1</sub>	J <sub>2</sub>	K	K <sub>1</sub>	L	L <sub>2</sub>
32	15	4	4	7.5	47	14	10	M6	M6	5	3	30	30	1/8	32.5	34.5	5	-	3	16	176	146
40	17.5	6	4.5	10	54	16	12	M6	M6	5	4	30	30	1/4	38	39.5	5	2	3	20	194	159
50	19	5.5	3	10.5	62	19	14	M8	M8	6	5	32	45	1/4	46.5	46.5	7.5	-	3	25	209	171
63	22	7.5	5	13	72	24	16	M10	M8	8	5	38	52	3/8	56.5	52.5	4.5	-	3	25	232	188
80	21	6.5	4	15	92	28	25	M12	M10	8	8	48	70	3/8	72	58.5	9.5	-	3	32	273	231
100	21	9	7	15	107	38	30	M14	M10	10	8	60	80	1/2	89	67	7.5	-	3	35	299	257

M	N	O	P	Q	R	S	TM	TF	U	V	V <sub>1</sub>	V <sub>2</sub>	W	W <sub>1</sub>	X	Y	ZM	ZF	CH	Δ
46	50	47	10	15	30	9	4	6.5	51.2	68	44.5	19	30	30	36	20	15	15	13	0.233
52	60	54	11	20	35	7	5	7.3	60	74	46	23	35	35	50	25	17	17	17	0.262
65	65	64	12	20	40	10	6	9.3	71	85	51	25	40	40	54	25	20	20	17	0.311
75	73	73.5	15	24	45	11	8	10.3	78	95	56	27.5	45	45	55	30	25	25	19	0.344
95	100	93.5	20	24	50	12.5	10	16	102	125	76	39	45	45	68	35	35	35	19	0.466
115	120	109	25	30	60	15	14.5	18.5	117	150	90	45	55	55	75	45	45	45	22	0.555

$$L_0 = L + 2 \cdot SL \quad L_1 = L_2 + 2 \cdot SL$$

$$SL = \alpha^\circ \cdot \Delta$$

Δ = Linear displacement (mm) for each degree of rotation

### KEY TO CODES

W	1	6	5	0	5	0	1	0	9	0
									ANGLE OF ROTATION*	
W165	cyl. with male piston			032	1			090		
W166	cyl. with female pinion			040	2			180		
				050				270		
				063				360		
				080						
				100						

\* expressed in sexagesimal degrees.

## ACCESSORIES: MAGNETIC SENSORS

### ORDERING CODES

Code	Description
W0950000201	REED SENSOR ACC. DSM2-C525 HS
W0950000222	E.HALL PNP SENSOR ACC. DSM3-N225
W0950000232	E.HALL NPN SENSOR ACC. DSM3-M225

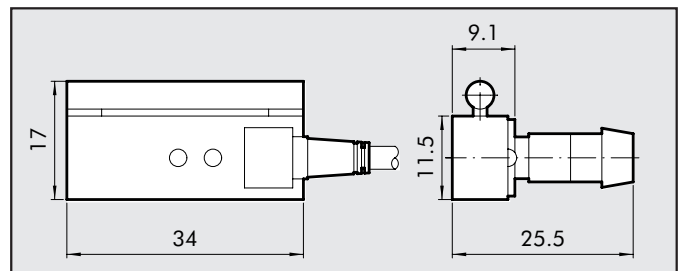

### SENSOR SUPPORT BRACKETS

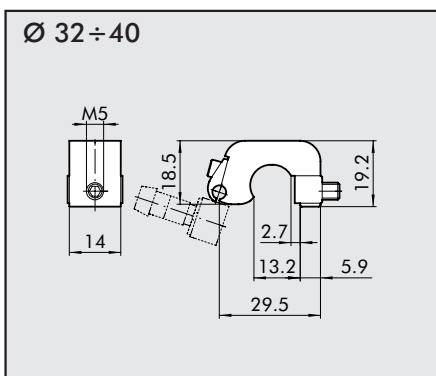

Code	Description
W0950000711	BRACKET ACC. D.32 DST 80

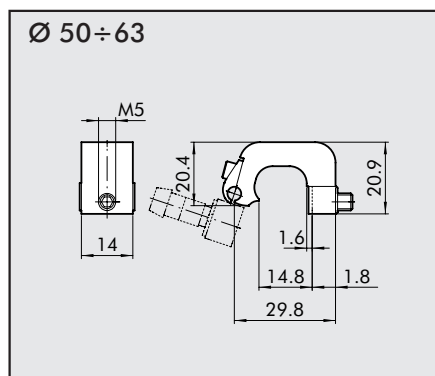

Code	Description
W0950000712	BRACKET ACC. D.50 DST 81

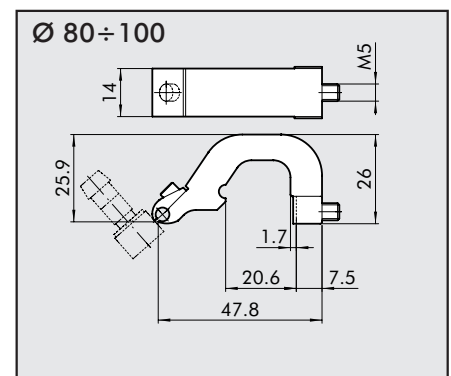

Code	Description
W0950000713	BRACKET ACC. D.80-100-125 DST 82