

ATOF® Blade Fuses

Rated 32V



Specifications

Voltage Rating:	32 VDC
Interrupting Rating:	1000A @ 32 VDC
*Recommended Environmental Temperature:	-40°C to +125°C
Terminals Material:	ATOF® (Tin Plated) / ATO Ag (Silver Plated)
Housing Material:	PA66 (U.L. 94 Flammability rating – V2)
Net Weight Per Fuse:	1.4±5% gr
Complies with:	SAE J1284,ISO 8820-3
UL Listed:	File AU1410
CSA Certified:	File No. 29862

*Tin plating's temperature limit is =130°C, Silver plating allows up to 150°C at the terminal interface.

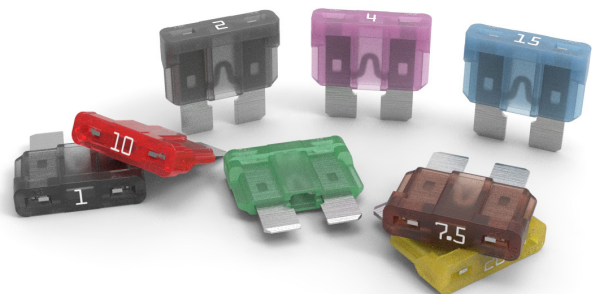

Description

ATOF® automotive blade fuses replaced obsolete ATO Series 257 fuses. Automakers in the United States and around the world consider ATOF® fuses standard equipment for protecting low-voltage circuits.

Applications

- Cars
- Trucks
- SUVs
- Offroad vehicles
- Buses
- Watercraft as approved by Littelfuse®

Features & Benefits

- Color coding shows the amperage rating for each fuse
- See-through housing makes it easy to check whether a fuse has blown
- Checkpoints on top make it possible to measure resistance without removing the fuse
- High-contrast amperage stamp on the top of the housing aids identification
- Simple to install and remove

Ordering Information

Part Number	Rating	Package Size
ATOF® (Tin Plated)		
0287xxx.PXCN	1 - 40	2000
0287xxx.U	1 - 40	500
0287xxx.H	1 - 40	100
0287xxx.L	1 - 40	50
ATO Ag (Silver Plated)		
0287xxx.PXS	1 - 40	2000

ATOF® Blade Fuses

Rated 32V

Ratings

Part Number	Current Rating (A)	Housing Material Color	Test Cable Size (mm ²)	Typ. Voltage Drop (mV)	Typ. Cold Resistance (mΩ)	Typ. I ² t (A ² s)
0287001_	1	Black	0.35	176	123	0.4
0287002_	2	Grey	0.35	141	53.5	1.4
0287003_	3	Purple	0.35	137	31.1	7.4
0287004_	4	Pink	0.35	136	22.8	14
0287005_	5	Brown	0.5	128	17.85	26
028707.5_	7.5	Dark Brown	0.75	116	10.91	60
0287010_	10	Red	1	109	7.70	115
0287015_	15	Blue	1.5	102	4.80	340
0287020_	20	Yellow	2.5	98	3.38	520
0287025_	25	Light Orange	2.5	92	2.52	1,000
0287030_	30	Green	4	84	1.97	1,500
0287035_	35	Dark Green	6	87	1.61	2,300
0287040_	40	Orange	6	96	1.44	3,300

The typical I²t is an average value calculated from the breaking capacity tests by using the melting time before the arcing occurs.

Dimensions

Dimensions in mm for reference only.
See outline drawing for dimensions and tolerances.

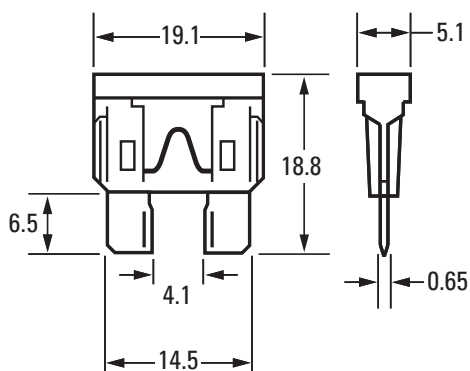

ATOF® Blade Fuses

Rated 32V

Time-Current Characteristic Curves

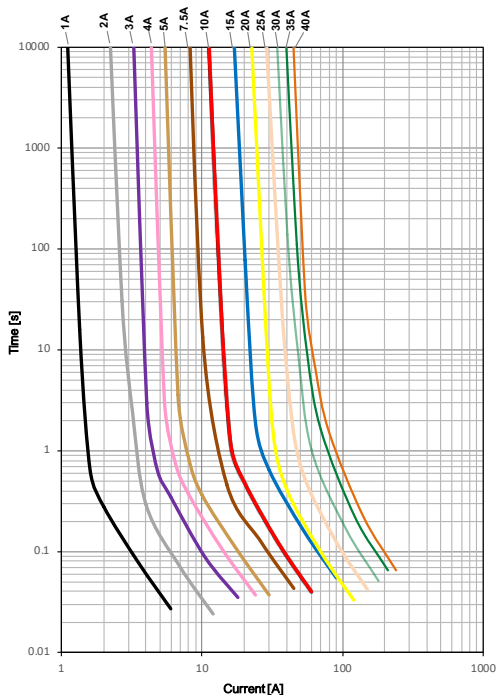

Time-Current Characteristics

% of Rating	Current Rating	Opening Time Min / Max (s)
100	35A & 40A	360,000 / ∞
110	1A-30A	360,000 / ∞
135	1A & 2A 3A-40A	0.35 / 600 0.750 / 600
160	1A-40A	0.250 / 50
200	1A & 2A 3A-40A	0.1 / 5 0.15 / 5
350	1A & 2A 3A-40A	0.02 / 0.5 0.08 / 0.5
600	1A-30A 35A & 40A	0.1 max 0.15 max

Typical Derating of Fuse Melting Element

Temperature Security Margin is 20%
 Wire Cross Section And Fixture Test Set Up Refer To ISO 8820-3
 Please Contact Littelfuse® For Details Regarding Derating Test Set Up

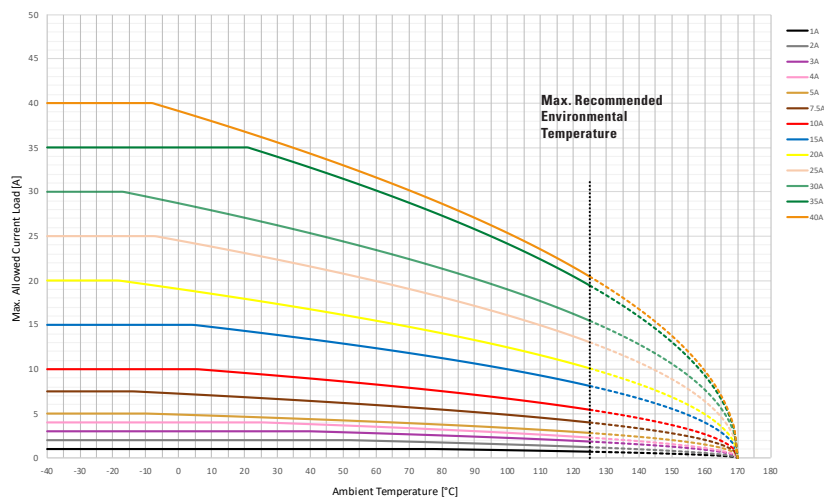

Temperature Table

	max. allowed current load [A] at ambient temperature (typical derating)						
	-40°C	0°C	20°C	65°C	85°C	110°C	125°C
1A	1	1	1	1	1	1	1
2A	2	2	2	2	2	1	1
3A	3	3	3	3	2	2	2
4A	4	4	4	3	3	3	2
5A	5	5	5	4	4	3	3
7.5A	8	7	7	6	5	5	4
10A	10	10	10	8	7	6	5
15A	15	15	14	12	11	9	8
20A	20	19	18	15	14	12	10
25A	25	25	23	19	18	15	13
30A	30	29	27	23	21	18	15
35A	35	35	35	29	27	22	19
40A	40	39	37	31	28	24	20

Derating curves may change depending on the final condition of the application (terminals characteristics, wire size etc.). Please ask Littelfuse® for more information.