

PISR

Engineer's Kit : EK-PISR

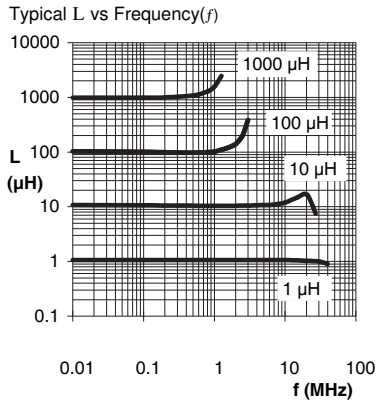
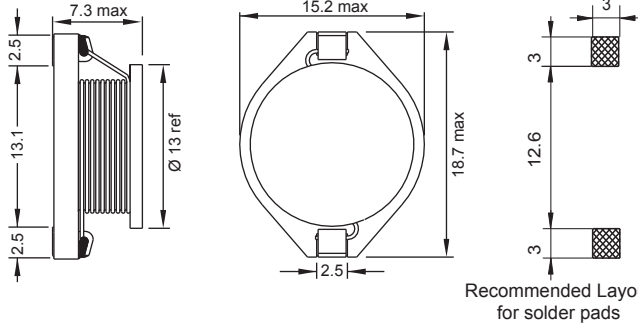

Part No	Inductance L (μH)	f. (MHz)	Tol \pm (%)	SRF min (MHz)	DCR max (Ω)	Rated DC Current (A)	
						I _{sat}	I _{ΔT=40°C}
PISR-1R0M-04	1	0.1	20	164	0.009	21	8.6
PISR-1R5M-04	1.5	0.1	20	160	0.007	-	7.4
PISR-2R2M-04	2.2	0.1	20	95	0.014	14	7.1
PISR-3R3M-04	3.3	0.1	20	72	0.017	15	6.4
PISR-4R7M-04	4.7	0.1	20	70	0.02	-	5.5
PISR-5R6M-04	5.6	0.1	20	41	0.022	12	5.5
PISR-6R8M-04	6.8	0.1	20	35	0.029	-	4.7
PISR-100M-04	10	0.1	20	24	0.029	10	4.5
PISR-150M-04	15	0.1	20	20	0.035	8	4.1
PISR-220M-04	22	0.1	20	15	0.04	7	3.6
PISR-330M-04	33	0.1	20	10	0.06	5.6	3.1
PISR-470M-04	47	0.1	20	8	0.07	4.6	2.7
PISR-680M-04	68	0.1	20	6.5	0.1	3.6	2.3
PISR-820M-04	82	0.1	20	6	0.15	3.1	1.9
PISR-101M-04	100	0.1	20	5.2	0.17	3.1	1.9
PISR-151M-04	150	0.1	20	4.2	0.22	2.6	1.6
PISR-221M-04	220	0.1	20	3.3	0.34	2.2	1.3
PISR-271M-04	270	0.1	20	3	0.52	1.9	1.1
PISR-331M-04	330	0.1	20	2.7	0.52	1.9	1.1
PISR-471M-04	470	0.1	20	2.1	0.76	1.4	0.85
PISR-681M-04	680	0.1	20	1.8	1.1	1.2	0.74
PISR-102M-04	1000	0.1	20	1.3	1.7	1	0.57

Material : Ferrite
SPQ : Reel 350 [-04]

Remark : I_{sat} & I _{Δ T} - see description in Inductors Technical Data page 58

All dimensions in mm

SMD Power Inductors