



Part no.: 50121904
BT318B-OM
Fastening

Figure can vary

Contents

- Technical data
- Dimensioned drawings
- Accessories

Part no.: 50121904 – BT318B-OM – Fastening

Technical data

Basic data

Suitable for 318 series sensors

Mechanical data

Chemical designation, plastic mounting devices	Polyoxymethylene (POM)
Design of mounting device	Mounting clamp
Type of fastening, at system	Through-hole mounting
Type of fastening, at device	Screw type
Type of mounting device	Adjustable Swiveling Turning
Mounting device material	Plastic
ITEM-compatible	No

Classification

Customs tariff number	39269097
eCl@ss 8.0	27279202
eCl@ss 9.0	27273701
ETIM 5.0	EC003015
ETIM 6.0	EC003015

Dimensioned drawings

All dimensions in millimeters

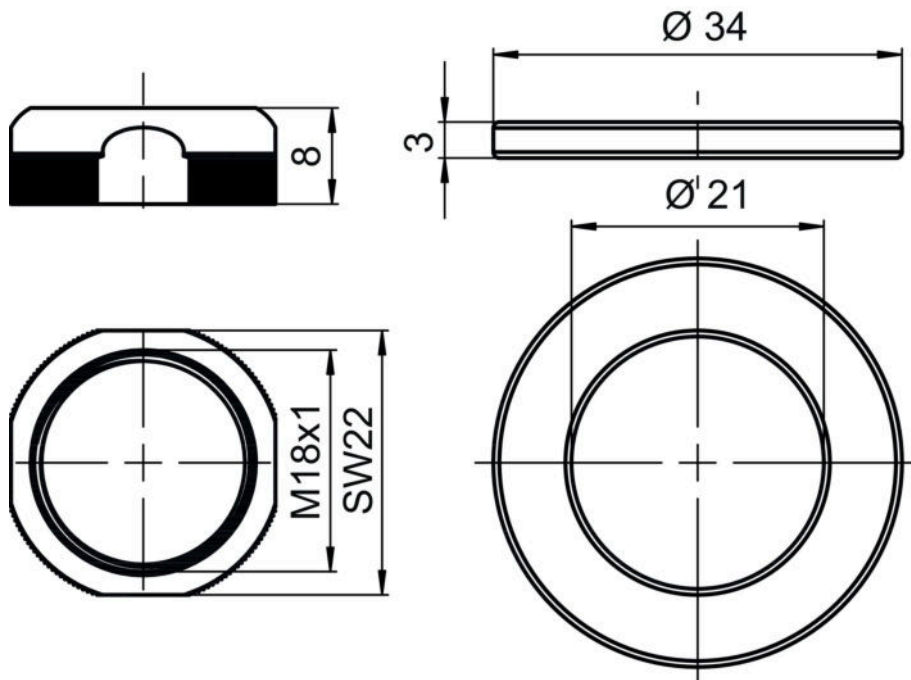

Part no.: 50121904 – BT318B-OM – Fastening

Accessories

Mounting technology - Other

	Part no.	Designation	Article	Description
	50117257	BT D21M	Mounting bracket	Diameter, inner: 21 mm Design of mounting device: Angle, L-shape Fastening, at system: Through-hole mounting Mounting bracket, at device: Screw type Type of mounting device: Adjustable Material: Metal

Note

A list with all available accessories can be found on the Leuze electronic website in the Download tab of the article detailed page.