



Compact Cylinder Series CQ2



Reduce the size and improve your machine's performance with the world's most flexible compact cylinder range from SMC

Small is definitely the new big:

The need for increased performance from smaller, more energy efficient machines are demands heard throughout the world. Today, small is definitely the new big for the many machine designers and machine builders.

As the worldwide leading experts in pneumatics, our continued investment in developing smaller, more compact, energy efficient components for factory automation applications can be seen throughout our extensive product range.

However, we are constantly reviewing and improving our product range and our newly redesigned and improved compact air operated cylinder range – Series CQ2 – is just one small example of our constant quest for product perfection.

Gain competitive advantage by discovering the benefits of using our improved CQ2 compact cylinder range

Series CQ2 – the facts:

The striking difference between our new CQ2 range and our previous model is the totally redesigned body, which offers improved auto-switch mounting possibilities plus an overall reduction of cylinder weight of between 5 -13% depending on the selected model, with any loss of body strength.

Whilst still delivering the same powerful performance, the compact size of this cylinder range coupled with this weight reduction now makes mounting even easier.

Our new CQ2 cylinders in bore sizes between \varnothing 32 to 200mm have been designed with slide in grooves which can accommodate auto-switches on all four cylinder sides without the need for auto-switch brackets. And, for smaller bore sizes between \varnothing 12 and 25mm, slide in grooves have also been integrated in the new body design to accommodate bracket free auto-switches on two surfaces.

Designed for use with our easy to set, dual colour, Series D-M9W auto-switch range, which illuminates green when the optimum position is located, the cylinders integrated auto-switch groove effectively eliminates the need for mounting brackets and protects the switch against accidental damage during installation and potential operator health and safety issues during machine maintenance checks.

Reduce your inventory costs and differentiate your machines from your competitors by discovering our new CQ2 compact cylinder range

Series CQ2 – the world's most flexible pneumatic cylinder range:

Flexibility is not a word that's often used to describe a pneumatic actuator, but with over 40 standard options, 6 mounting types and excellent auto switch mounting positionability, our improved Series CQ2, really is the most flexible, compact designed, air actuator in the world!

Suitable for almost all machine applications and available in 15 bore sizes from 12mm – 200mm (depending on your selected model), our CQ2 range could be the perfect solution - to help reduce your current stock inventory and also to differentiate your machines from your competitors.

Our Series CQ2 really is a truly outstanding range of pneumatic cylinders!

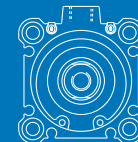

Compact overall dimensions in any size

Exclusive bodies (-XB10) for $\varnothing 32$ to $\varnothing 100$ intermediate strokes (50 mm or more) now kept in inventory*, enabling shorter delivery times.
 * Formerly produced upon receipt of order

Bore size (mm)	Stroke										
	50	55	60	65	70	75	80	85	90	95	100
$\varnothing 32$ to $\varnothing 100$	◆	●	●	●	●	◆	●	●	●	●	◆

◆ Standard stroke ● Currently stocked intermediate stroke

And the most innovative solutions in compact design

Built-in one-touch fittings

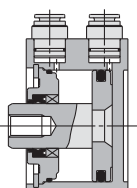

Cylinder with valve



Compact Cylinder with air cushion



With the most compact and flexible auto-switch mounting

■ Auto-switches can be mounted on 4 surfaces.

$\varnothing 32$ to $\varnothing 200$

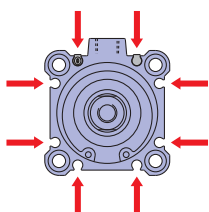

■ 2 switches can be mounted on the same surface.

$\varnothing 12$ to $\varnothing 25$

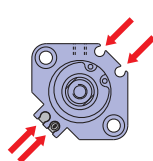

($\varnothing 12$: One slot for each surface)

■ No protrusion of auto switch

- Prevention of damage to auto switch.
- Sleeves cannot get caught in the auto switch and its mounting rail.
- Reduction in labour for design.

There is no need to check for interference with a machine, because the outer dimensions of the cylinder do not change when the auto switch is mounted.

■ Reduction in labour for work

NEW

- Reduction in number of components
- No loss of components

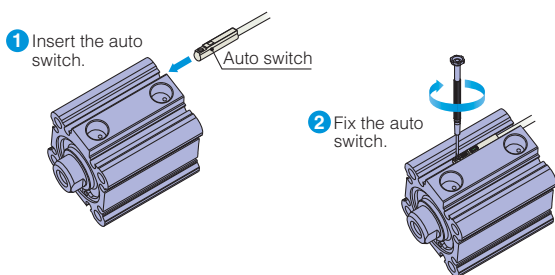

■ Reduction in labour for design

NEW

- The auto switch can be replaced with the foot brackets mounted.

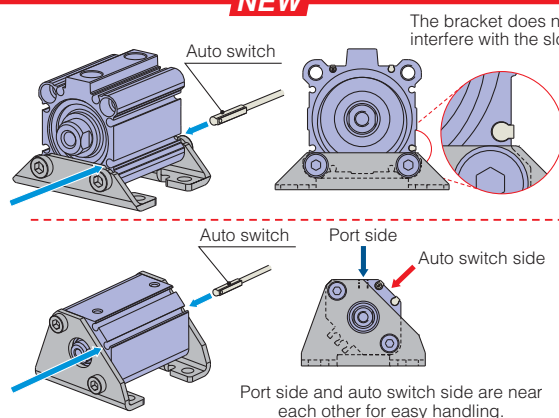

■ Small auto switch

- 2-colour indication solid state auto switch
- Appropriate setting of the mounting position can be performed without mistakes.





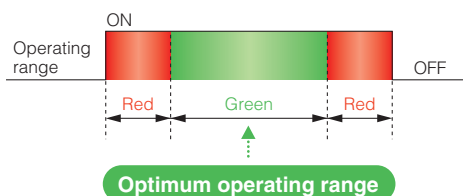



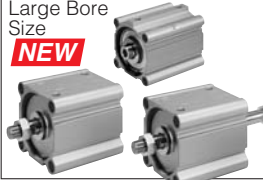

A green light illuminates up at the optimum operating range.

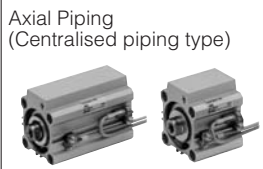

With a short overall length, the space-saving cylinder helps to make various jigs and equipment more compact.

Series Variations

Series	Action	Type	Bore size (mm)	Standard stroke (mm)
NEW 	Double acting	Single rod CQ2	12 16 20 25 32 40 50 63 80 100	$\phi 12, \phi 16$: 5 to 30 $\phi 20, \phi 25$: 5 to 50 $\phi 32, \phi 40$: 5 to 100 $\phi 50$ to $\phi 100$: 10 to 100
		Double rod CQ2W	12 16 20 25 32 40 50 63 80 100	$\phi 12, \phi 16$: 5 to 30 $\phi 20, \phi 25$: 5 to 50 $\phi 32, \phi 40$: 5 to 100 $\phi 50$ to $\phi 100$: 10 to 100
	Single acting	Spring return/ Spring extend CQ2	12 16 20 25 32 40 50	$\phi 12$ to $\phi 40$: 5, 10 $\phi 50$: 10, 20
NEW 	Double acting	Single rod CQ2	125 140 160 180 200	10 to 300
		Double rod CQ2W	125 140 160 180 200	10 to 300
NEW 	Double acting	Single rod CQ2	125 140 160 180 200	125 to 300
NEW 	Double acting	Single rod CQ2K	12 16 20 25 32 40 50 63	$\phi 12, \phi 16$: 5 to 30 $\phi 20, \phi 25$: 5 to 50 $\phi 32, \phi 40$: 5 to 100 $\phi 50, \phi 63$: 10 to 100
		Double rod CQ2KW	12 16 20 25 32 40 50 63	$\phi 12, \phi 16$: 5 to 30 $\phi 20, \phi 25$: 5 to 50 $\phi 32, \phi 40$: 5 to 100 $\phi 50, \phi 63$: 10 to 100
	Double acting	Single rod CQP2	12 16 20 25 32 40 50 63 80 100	$\phi 12, \phi 16$: 5 to 30 $\phi 20, \phi 25$: 5 to 50 $\phi 32, \phi 40$: 5 to 100 $\phi 50$ to $\phi 100$: 10 to 100
	Single acting	Spring return/ Spring extend CQP2	12 16 20 25 32 40 50	$\phi 12$ to $\phi 40$: 5, 10 $\phi 50$: 10, 20
NEW 	Double acting	Single rod CQ2□S	32 40 50 63 80 100	$\phi 32$ to $\phi 40$: 5 to 100 $\phi 50$ to $\phi 100$: 10 to 100
	Double acting	Single rod CBQ2	20 25 32 40 50 63 80 100	$\phi 20$ to $\phi 63$: 10 to 100 $\phi 80, \phi 100$: 25 to 100
NEW 	Double acting	Single rod CQ2□R	20 25 32 40 50 63 80 100	$\phi 20, \phi 25$: 5 to 50 $\phi 32, \phi 40$: 5 to 100 $\phi 50$ to $\phi 100$: 10 to 100
		Refer to Best Pneumatics No. 3.		
		Refer to Best Pneumatics No. 3.		

How to order

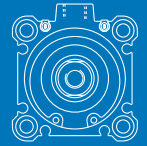

Compact Cylinder: Standard Single/Double Acting, Single/Double Rod

Series CQ2/CQ2W

ø12, ø16, ø20, ø25, ø32, ø40, ø50, ø63, ø80, ø100

Without built-in magnet
ø12 to ø25

Without built-in magnet
ø32 to ø100

With built-in magnet

CQ2 **B** **20** - **30**

CQ2 **B** **32** - **30** **Z**

CDQ2 **B** **32** - **30** **Z**

With built-in magnet

Type

—	Single rod
W	Double rod

Mounting

B	Through-hole (Standard)
A	Both ends tapped

* Cylinder mounting bolts are not included. Order them separately.

Type

—	Pneumatic
H	Air-hydro ^{Note 1, 2)}

Note 1) Bore sizes available for air-hydro type are ø20 to ø100.
Note 2) Option only available for double acting types.

Bore size

12	12 mm
16	16 mm
20	20 mm
25	25 mm
32	32 mm
40	40 mm
50	50 mm
63	63 mm ^{Note 3)}
80	80 mm ^{Note 3)}
100	100 mm ^{Note 3)}

Note 3) Bore available for double acting types.

Port thread type

—	M thread	ø12 to ø25
	Rc	
TN	NPT	ø32 to ø100
TF	G ^{Note 4)}	
F	Built-in one-touch fittings ^{Note 5)}	

Note 4) "TF" is not available for air-hydro type.
Note 5) Bore sizes available with one-touch fittings are ø32 to ø63. Besides, it is not possible to use for air-hydro type.
* For cylinders without auto switch, M threads are compatible only for ø32-5 mm stroke.

Auto switch mounting groove

Z	ø12 to ø25	2 surfaces
	ø32 to ø100	4 surfaces

Note 11) The made-to-order, heat resistant auto switch -XB14 is not applicable.

Body option

—	Standard (Rod end female thread)
F	With boss on head end ^{Note 8)}
C	With rubber bumper ^{Note 9, 10)}
M	Rod end male thread

* Combination of body options ("CM", "FC", "FM", "FCM") is available.
Note 8) Option only available for single rod types.
Note 9) Option only available for double acting types.
Note 10) Air-hydro type with rubber bumper is not available.

Action

D	Double acting ^{Note 6)}
S	Single acting, Spring return ^{Note 7)}
T	Single acting, Spring extend ^{Note 7)}

Note 6) Option for double acting types.
Note 7) Option only available for single acting types.

Cylinder stroke (mm)

Pneumatic type (Double Acting types)

Bore size	Standard stroke
12, 16	5, 10, 15, 20, 25, 30
20, 25	5, 10, 15, 20, 25, 30, 35, 40, 45, 50
32, 40	5, 10, 15, 20, 25, 30, 35, 40, 45, 50, 75, 100
50 to 100	10, 15, 20, 25, 30, 35, 40, 45, 50, 75, 100

Air-hydro type (Double Acting types)

Bore size	Standard stroke
20, 25	5, 10, 15, 20, 25, 30, 35, 40, 45, 50
32, 40	5, 10, 15, 20, 25, 30, 35, 40, 45, 50, 75, 100
50, 63, 80, 100	10, 15, 20, 25, 30, 35, 40, 45, 50, 75, 100

Single Acting types

Bore size	Standard stroke
12, 16, 20, 25, 32, 40	5, 10
50	10, 20



Manufacture of Intermediate Strokes (Except air-hydro type)

1. Spacer-installed type 1: Standard model number

Intermediate stroke with ◉: Available in 1 mm intervals

A spacer is installed on tubes with a stroke longer than the specified stroke (◆).

◆: Standard stroke

Bore size (mm)	Stroke range	Type	Stroke																			
			5	10	15	20	25	30	35	40	45	50	75	100								
12, 16	1 to 29	Spacer-installed type 1	◉◆	◉◆	◉◆	◉◆	◉◆	◉◆	◉◆	◉◆	◉◆	◉◆	◉◆	◉◆	◉◆	◉◆	◉◆	◉◆	◉◆	◉◆		
20, 25	1 to 49		◉◆	◉◆	◉◆	◉◆	◉◆	◉◆	◉◆	◉◆	◉◆	◉◆	◉◆	◉◆	◉◆	◉◆	◉◆	◉◆	◉◆	◉◆		
32, 40	1 to 99		◉◆	◉◆	◉◆	◉◆	◉◆	◉◆	◉◆	◉◆	◉◆	◉◆	◉◆	◉◆	◉◆	◉◆	◉◆	◉◆	◉◆	◉◆		
50 to 100	1 to 99		◉◆	◉◆	◉◆	◉◆	◉◆	◉◆	◉◆	◉◆	◉◆	◉◆	◉◆	◉◆	◉◆	◉◆	◉◆	◉◆	◉◆	◉◆		

Ordering example (when ordering ø32-57 mm stroke (with through-hole (standard), without switch)

Type	1. Spacer-installed type 1
Part no.	Standard model number
Order no.	CQ2B32-57DZ (uses 75 mm stroke tube) • CQ2B32-75DZ with 18 mm width spacer inside • The B dimension is 108 mm.

2. Spacer-installed type 2: Suffix “-XB10A”

Intermediate stroke with ◉: Available in 1 mm intervals

A spacer is installed on tubes with a stroke longer than the specified stroke (●).

◆: Standard stroke ●: Stroke in stock

Bore size (mm)	Stroke range	Type	Stroke																
			55	60	65	70	*	75	80	85	90	95	*	100					
32, 40	51 to 94	Spacer-installed type 2	◉●	◉●	◉●	◉●	◉●	◉●	◉●	◉●	◉●	◉●	◉●	◉●	◉●	◉●	◉●	◉●	◉●
50 to 100	51 to 94		◉●	◉●	◉●	◉●	◉●	◉●	◉●	◉●	◉●	◉●	◉●	◉●	◉●	◉●	◉●	◉●	◉●

Ordering example (when ordering ø32-57 mm stroke (with through-hole (standard), without switch)

Type	2. Spacer-installed type 2
Part no.	Suffix “-XB10A” to the end of model number.
Order no.	CQ2B32-57DZ-XB10A (uses 60 mm stroke tube) • CQ2B32-60DZ-XB10 with 3 mm width spacer inside • The B dimension is 93 mm.

Note) Specify a spacer-installed type 1 with standard model number for ordering an intermediate stroke with a * mark.

3. Exclusive body type: Suffix “-XB10”

Available in 1 mm intervals

Exclusive body can be manufactured for specified stroke upon request.

Bore size (mm)	Stroke range	Type
12, 16	6 to 29	Exclusive body
20, 25	6 to 49	
32, 40	6 to 99	
50 to 100	11 to 99	

Note) In the case of exclusive body type with ø32 to ø100 (-XB10) with the stroke length exceeding 50 mm, reference values of the longitudinal dimension (A/B dimension) will be the same as those with auto switch. Refer to page 185 for details.

Ordering example

(when ordering ø32-57 mm stroke (with through-hole (standard), without switch)

Type	3. Exclusive body type
Part no.	Suffix “-XB10” to the end of model number.
Order no.	CQ2B32-57DZ-XB10 (uses 57 mm stroke tube) • Makes 57 mm stroke tube. • The B dimension is 90 mm.

For 55, 60, 65, 70, 80, 85, 90, and 95 stroke, exclusive bodies are kept in inventory, enabling shorter delivery times.

Retaining Ring Installation/Removal

⚠ Caution

- For installation and removal, use an appropriate pair of pliers (tool for installing a type C retaining ring).
- Even if a proper plier (tool for installing a type C retaining ring) is used, it is likely to inflict damage to a human body or peripheral equipment, as a retaining ring may be flown out of the tip of a plier (tool for installing a type C retaining ring). Be much careful with the popping of a retaining ring. Besides, be certain that a retaining ring is placed firmly into the groove of rod cover before supplying air at the time of installment.

Mounting

⚠ Caution

The CQ2 series compact cylinders are designed to create compact mechanical equipment and promote space saving. Thus, if it is used in the same manner as conventional cylinders such as tie-rod cylinders, it may degrade the performance. Pay sufficient attention to the operating conditions when using.

Mounting

⚠ Caution

- Allowable lateral load**
Lateral load that can apply to the piston rod end is limited. If a cylinder is used with lateral load over the limit, it may cause air leakage due to abnormal friction of seals, galling of cylinder tubes and pistons, or abnormal friction of the bearing part. The lateral load applied to the piston rod must be within the allowable range indicated in this catalogue. When the load exceeds the limit, use a double rod cylinder, install a guide, or change the bore size to suit the load in order to make the load within the allowable range. As a standard product, an anti-lateral load type cylinder that is resistant to approx. 2 times more than the conventional compact CQ2 series is also available.
- Connection with a work piece**
When a work piece is mounted on the piston rod end, connect them aligning the center of piston rod and a work piece. If they are off-center, lateral load is generated and phenomena mentioned in (1) may occur. In order not to apply the off-center load, use of a floating joint or simple joint is recommended.

- Simultaneous use of multiple cylinders**
It is difficult to control the speed of pneumatic cylinders. The following conditions cause speed change: change in supply pressure, load, temperature and lubrication, performance difference of each cylinder, deterioration of each part over time, etc. Aspeed controller can be used to control the speed of multiple cylinders simultaneously for a short period of time, but depending on conditions, it may not work as desired. If multiple cylinders cannot operate simultaneously, unreasonable force is applied to the piston rod because cylinder positions may not be the same. This may cause abnormal friction of seals and bearings, and galling of cylinder tubes and pistons. Do not use an application to operate several cylinders simultaneously by adjusting cylinder speed. If this is inevitable, use a high rigid guide against load, so that the cylinder is not damaged even when the each cylinder output is slightly different.

How to order

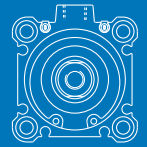

Compact Cylinder: Large Bore Size Double Acting, Single/Double Rod

Series CQ2/CQ2W

ø125, ø140, ø160, ø180, ø200

Without built-in magnet

CQ2 **B** **125** - **30** **DC** **Z**

With built-in magnet

CDQ2 **B** **125** - **30** **DC** **Z**

With built-in magnet ●

Type ●

—	Single rod
W	Double rod

Mounting ●

B Through-hole/Both ends tapped common (Standard)

* Cylinder mounting bolts are not included. Order them separately.

Bore size ●

125	125 mm
140	140 mm
160	160 mm
180	180 mm
200	200 mm

Port thread type ●

—	Rc
TN	NPT
TF	G

Auto switch mounting groove ●

Z ø125 to ø200 4 surfaces

Body option ●

—	Standard (Rod end female thread)
M	Rod end male thread

Cushion ●

C Rubber bumper

Action ●

D Double acting

Cylinder stroke (mm) ●

Bore size (mm)	Standard stroke
125, 140, 160	10, 20, 30, 40, 50, 75, 100, 125, 150, 175, 200, 250, 300
180, 200	

How to order

Compact Cylinder: Long Stroke Double Acting, Single Rod

Series CQ2

ø32, ø40, ø50, ø63, ø80, ø100

Without built-in magnet **CQ2** **A** **32** **□** - **200** **DC** **□** **Z**

With built-in magnet **CDQ2** **A** **32** **□** - **200** **DC** **□** **Z**

With built-in magnet ●

Mounting ●

A	Both ends tapped
----------	------------------

Bore size ●

32	32 mm
40	40 mm
50	50 mm
63	63 mm
80	80 mm
100	100 mm

Port thread type ●

—	Rc
TN	NPT
TF	G
F	Built-in one-touch fittings <small>Note)</small>

Note) Bore sizes available with one-touch fittings are ø32 to ø63.



Auto switch mounting groove ●

Z	4 surfaces
----------	------------

Body option ●

—	Standard (Rod end female thread)
M	Rod end male thread

Cushion ●

C	Rubber bumper
----------	---------------

Action ●

D	Double acting
----------	---------------

Cylinder stroke (mm) ●

Bore size	Standard stroke
32, 40, 50 63, 80, 100	125, 150, 175, 200, 250, 300

How to order

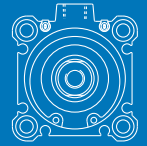

Compact Cylinder: Non-rotating Rod Double Acting, Single/Double Rod

Series CQ2K/CQ2KW

ø12, ø16, ø20, ø25, ø32, ø40, ø50, ø63

Without built-in magnet
ø12 to ø25

Without built-in magnet
ø32 to ø63

With built-in magnet

CQ2K **B** 20 - **30** **D**

CQ2K **B** 32 - **30** **D** **Z**

CDQ2K **B** 32 - **30** **D** **Z**

With built-in magnet

Non-rotating rod

Type

—	Single rod
W	Double rod

Mounting

B	Through-hole (Standard)	ø12 to ø63
A	Both ends tapped	ø40, ø50, ø63

* Cylinder mounting bolts are not included. Order them separately.

Auto switch mounting groove

Z	ø12 to ø25	2 surfaces
	ø32 to ø63	4 surfaces

Body option

—	Standard (Rod end female thread)
F	With boss on head end ^{Note 3)}
C	With rubber bumper (ø12 with auto switch only)
M	Rod end male thread

* Combination of body options ("FM") is available. Note 3) Option only available for single rod types.

Action

D	Double acting
---	---------------

Cylinder stroke (mm)

Bore size	Standard stroke
12, 16	5, 10, 15, 20, 25, 30
20, 25	5, 10, 15, 20, 25, 30, 35, 40, 45, 50
32, 40	5, 10, 15, 20, 25, 30, 35, 40, 45, 50, 75, 100
50, 63	10, 15, 20, 25, 30, 35, 40, 45, 50, 75, 100

Bore size

12 ^{Note 1)}	12 mm	32	32 mm
16	16 mm	40	40 mm
20	20 mm	50	50 mm
25	25 mm	63	63 mm

Note 1) When ø12 with auto switch is required, the body option should be with rubber bumper (C). Example) CDQ2KB12-30DCZ

Port thread type

—	M thread	ø12 to ø25
	Rc	
TN	NPT	ø32 to ø63
TF	G	
F	Built-in one-touch fittings ^{Note 2)}	

Note 2) Bore sizes available with one-touch fittings are ø32 to ø63.
* For cylinders without auto switch, M threads are compatible only for ø32-5 mm stroke model.

How to order

Compact Cylinder: Axial Piping Single/Double Acting, Single Rod

Series CQP2

ø12, ø16, ø20, ø25, ø32, ø40, ø50, ø63, ø80, ø100

Without auto switch

CQP2B **50** - **30** **D**

With auto switch

CDQP2B **50** - **30** **D**

With auto switch
(Built-in magnet)

Axial piping

Mounting

B Through-hole

* Cylinder mounting bolts are not included. Order them separately.

Type

—	Pneumatic
H	Air-hydro ^{Note 1, 2)}

Note 1) Bore sizes available for air-hydro type are ø20 to ø100.
Note 2) Option only available for double acting type.

Bore size

12	12 mm
16	16 mm
20	20 mm
25	25 mm
32	32 mm
40	40 mm
50	50 mm
63	63 mm ^{Note 3)}
80	80 mm ^{Note 3)}
100	100 mm ^{Note 3)}

Note 3) Bore only available for double acting type.

Port thread type

—	M thread	ø12 to ø25
	Rc	
TN	NPT	ø32 to ø100
TF	G	



Body option

—	Standard (Rod end female thread)
C	With rubber bumper ^{Note 6, 7)}
M	Rod end male thread

* Combination of body option ("CM") is available.
Note 6) Air-hydro type with rubber bumper is not available.
Note 7) Option only available for double acting type.

Action

D	Double acting ^{Note 4)}
S	Single acting, Spring return ^{Note 5)}
T	Single acting, Spring extend ^{Note 5)}

Note 4) Option for double acting type.
Note 5) Option only available for single acting type.

Cylinder stroke (mm)

Pneumatic type (Double Acting types)	
Bore size	Standard stroke
12, 16	5, 10, 15, 20, 25, 30
20, 25	5, 10, 15, 20, 25, 30, 35 40, 45, 50
32, 40	5, 10, 15, 20, 25, 30, 35 40, 45, 50, 75, 100
50, 63 80, 100	10, 15, 20, 25, 30, 35, 40 45, 50, 75, 100

Air-hydro type (Double Acting types)	
Bore size	Standard stroke
20, 25	5, 10, 15, 20, 25, 30, 35 40, 45, 50
32, 40	5, 10, 15, 20, 25, 30, 35 40, 45, 50, 75, 100
50, 63 80, 100	10, 15, 20, 25, 30, 35, 40 45, 50, 75, 100

Single Acting types	
Bore size	Standard stroke
12, 16, 20 25, 32, 40	5, 10
50	10, 20

How to order

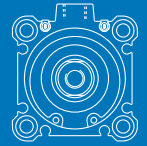

Compact Cylinder: Anti-lateral Load Double Acting, Single Rod

Series CQ2

ø32, ø40, ø50, ø63, ø80, ø100

Without built-in magnet

CQ2 B S 32 - 30 D C Z

With built-in magnet

CDQ2 B S 32 - 30 D C Z

Mounting

B	Through-hole (Standard)
A	Both ends tapped

* Cylinder mounting bolts are not included. Order them separately.

Type

S	Anti-lateral load
----------	-------------------

Bore size

32	32 mm
40	40 mm
50	50 mm
63	63 mm
80	80 mm
100	100 mm

Port thread type

—	Rc
TN	NPT
TF	G

Cylinder stroke (mm)

Bore size	Standard stroke
32, 40	5, 10, 15, 20, 25, 30, 35, 40, 45, 50, 75, 100
50, 63, 80, 100	10, 15, 20, 25, 30, 35, 40, 45, 50, 75, 100

Auto switch mounting groove

Z	4 surfaces
----------	------------

Body option 2

—	Standard (Rod end female thread)
M	Rod end male thread

Cushion

C	Rubber bumper
----------	---------------

Body option 1

—	Standard
F	With boss on head end

Action

D	Double acting
----------	---------------

How to order

Compact Cylinder: With End Lock Double Acting, Single Rod

Series CBQ2

ø20, ø25, ø32, ø40, ø50, ø63, ø80, ø100

Without auto switch

CBQ2 **B** **40** **□** - **30** **D** **C** **□** - **H** **N**

With auto switch

CDBQ2 **B** **40** **□** - **30** **D** **C** **□** - **H** **N**

With auto switch
(Built-in magnet)

Manual release type

N	Non-lock type
L	Lock type

Lock position

H	Head end lock
R	Rod end lock

Body option

—	Rod end female thread
CM	Rod end male thread

Cushion

C	Rubber bumper
----------	---------------

Action

D	Double acting
----------	---------------



ø20, ø25

B	Through-hole/Both ends tapped common (Standard)
L	Foot
F	Rod flange
G	Head flange
D	Double clevis

Note 1) Mounting brackets are shipped together, (but not assembled).

Note 2) At the 75 and 100 mm strokes with ø80, ø100, both ends tapped (A) is the standard. Through-hole (B) is not available.

ø32 to ø100

B	Through-hole (Standard) ^{Note 2)}
A	Both ends tapped
L	Foot
F	Rod flange
G	Head flange
D	Double clevis

Note 3) Mounting brackets are shipped together, (but not assembled).

Mounting

Bore size

20	20 mm	50	50 mm
25	25 mm	63	63 mm
32	32 mm	80	80 mm
40	40 mm	100	100 mm

Port thread type

—	M thread	ø20, ø25
	Rc	
TN	NPT	ø32 to ø100
TF	G	

Cylinder stroke (mm)

Bore size	Standard stroke
20 a 63	10, 15, 20, 25, 50, 75, 100
80, 100	25, 50, 75, 100

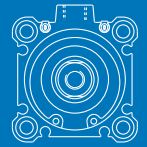

Compact Cylinder: Water Resistant Double Acting, Single Rod

Series CQ2

ø20, ø25, ø32, ø40, ø50, ø63, ø80, ø100

Without built-in magnet ø20, ø25	CQ2	B	20		R	-	30	D	
Without built-in magnet ø32 to ø100	CQ2	B	32		R	-	30	D	Z
With built-in magnet	CDQ2	B	32		R	-	30	D	Z

With built-in magnet

Mounting

B	Through-hole (Standard)	(ø20 to ø100)
A	Both ends tapped	(ø40 to ø100)

* Cylinder mounting bolts are not included.
Order them separately.

Bore size

20	20 mm
25	25 mm
32	32 mm
40	40 mm
50	50 mm
63	63 mm
80	80 mm
100	100 mm

Port thread type

—	M thread
	Rc
TN	NPT
TF	G

Water resistant cylinder

R	NBR seal (Nitrile rubber)
V	FKM seal (Fluororubber)

Auto switch mounting groove

Z	ø20 to ø25	2 surfaces
	ø32 to ø100	4 surfaces

Body option

—	Standard (Rod end female thread)
M	Rod end male thread

Action

D	Double acting
----------	---------------

Cylinder stroke (mm)

Bore size	Standard stroke
20, 25	5, 10, 15, 20, 25, 30, 35, 40, 45, 50
32, 40	5, 10, 15, 20, 25, 30, 35, 40, 45, 50, 75, 100
50, 63, 80, 100	10, 15, 20, 25, 30, 35, 40, 45, 50, 75, 100

Specifications

Pneumatic type

Bore size (mm)	12	16	20	25	32	40	50	63	80	100	125	140	160	180	200
Fluid	Air														
Proof pressure	1.5 MPa														1.05 MPa
Maximum operating pressure	1.0 MPa														0.7 MPa
Minimum operating pressure	Double acting type	0.07 MPa		0.05 MPa											
	Single acting type	0.25 MPa	0.18 MPa		0.17 MPa	0.15 MPa	0.13 MPa	—							
Ambient and fluid temperature	Without auto switch: -10 to 70°C (No freezing) With auto switch: -10 to 60°C (No freezing)														
Lubrication	Not required (Non-lube)														
Piston speed	50 to 500 mm/s														20 to 400 mm/s
Allowable kinetic energy (J)	Standard	0.022	0.038	0.055	0.09	0.15	0.26	0.46	0.77	1.36	2.27	—			
	With rubber bumper	0.043	0.075	0.11	0.18	0.29	0.52	0.91	1.54	2.71	4.54	7.4	9.8	12.4	
Stroke length tolerance												+1.0 mm (Note) 0		+1.4 mm (Note) 0	

Note) Stroke length tolerance does not include the amount of bumper change.

With rubber bumper type is standard form ø25 to ø200 bore.

Air-hydro type

Bore size (mm)	20	25	32	40	50	63	80	100
Fluid	Turbine oil (Note)							
Proof pressure	1.5 MPa							
Maximum operating pressure	1.0 MPa							
Minimum operating pressure	0.18 MPa			0.1 MPa				
Ambient and fluid temperature	5 to 60°C							
Piston speed	5 to 50 mm/s							
Cushion	None							
Stroke length tolerance	+1.0 mm 0							

Note) Refer to "Handling Precautions for SMC Products" (M-E03-3) for Actuator Precautions (5).

Mounting Brackets/Part No.

Standard (Note 4)

Bore size (mm)	Model	Foot (Note 1)	Flange	Double clevis (Note 3)	
12	Without switch	CQ2□□-□D	CQ-L012	CQ-F012	CQ-D012
	With switch	CQ2□□-□DZ	CQ-LZ12		
16	Without switch	CQ2□□-□D	CQ-L016	CQ-F016	CQ-D016
	With switch	CQ2□□-□DZ	CQ-LZ16		
20	Without switch	CQ2□□-□D	CQ-L020	CQ-F020	CQ-D020
	With switch	CQ2□□-□DZ	CQ-LZ20		
25	Without switch	CQ2□□-□D	CQ-L025	CQ-F025	CQ-D025
	With switch	CQ2□□-□DZ	CQ-LZ25		
32		CQ2□□-□DZ	CQ-L032	CQ-F032	CQ-D032
40		CQ2□□-□DZ	CQ-L040	CQ-F040	CQ-D040
50		CQ2□□-□DZ	CQ-L050	CQ-F050	CQ-D050
63 (Note 2)		CQ2□□-□DZ	CQ-L063	CQ-F063	CQ-D063
80 (Note 2)		CQ2□□-□DZ	CQ-L080	CQ-F080	CQ-D080
100 (Note 2)		CQ2□□-□DZ	CQ-L100	CQ-F100	CQ-D100

Note 1) When ordering a foot bracket, the required quantity will be different depending on the bore size.

- ø12 to ø25:
 - Without switch: Order 2 pieces per cylinder.
 - With switch: Order 1 piece per cylinder. (Part number for a set of 2 foot brackets)
- ø32 to ø100:
 - Order 2 pieces per cylinder.

Note 2) Not applicable to single acting types.

Note 3) Not applicable to double acting, double rod types.

Note 4) Parts belonging to each bracket are as follows.

- Foot or Flange: Body mounting bolts
- Double clevis: Clevis pin, Type C retaining rings for axis, Body mounting bolts

Note 5) Clevis pin and retaining rings are included with double clevis.

Note 6) When ordering a foot bracket, order 2 pieces per cylinder.

Note 7) Only applicable to CQ2 with end lock types.

Note 8) Not applicable to non-rotating single rod type and water resistant type.

Note 9) Not applicable to non-rotating single rod type.

Long stroke; Non-rotating single rod; Antilateral load; Water resistant; With end lock (Note 5)

Bore size (mm)	Foot (Note 6)	Flange	Double clevis (Note 4)
20 (Note 7)	CQS-L020	CQS-F020	CQS-D020
25 (Note 7)	CQS-L025	CQS-F025	CQS-D025
32 (Note 8)	CQ-L032	CQ-F032	CQ-D032
40	CQ-L040	CQ-F040	CQ-D040
50	CQ-L050	CQ-F050	CQ-D050
63	CQ-L063	CQ-F063	CQ-D063
80 (Note 9)	CQ-L080	CQ-F080	CQ-D080
100 (Note 9)	CQ-L100	CQ-F100	CQ-D100

Non-rotating, double rod

Bore size (mm)	Foot (Note 6)	Flange
40	CQ-L040	CQ-F040
50	CQ-L050	CQ-F050
63	CQ-L063	CQ-F063

Auto-switches

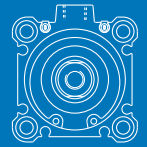

Applicable CQ2 cylinder		Part number	Wiring output	Model	Lead wire length	Pre-wired connector	Mounting surface	Mounting bracket										
Standard NEW 	General purpose solid state auto-switch	D-M9BWL	2 wire	In-line	3 m	—		Not required										
		D-M9BWVL		Perpendicular														
		D-M9PWL	3 wire (PNP)	In-line	3 m	—												
		D-M9PWVL		Perpendicular														
		D-M9PWSAPC	3 wire (PNP)	In-line	0,5 m	M8 (3 pin)												
		D-M9PWVSAPC		Perpendicular														
Large Bore Size NEW 	Water resistant solid state auto-switch	D-M9BAL	2 wire	In-line	3 m	—		Not required										
		D-M9BAVL		Perpendicular														
		D-M9PAL	3 wire (PNP)	In-line	3 m	—												
		D-M9PASAPC		Perpendicular														
		D-A93L	2 wire	In-line	3 m	—												
		D-A93VL		Perpendicular														
D-A93SAPC	In-line	0,5 m	M8 (3 pin)															
Long Stroke NEW 	General purpose reed auto-switch	D-A73L	2 wire	Perpendicular	3 m	—		<table border="1"> <thead> <tr> <th>Bore size</th> <th>Bracket</th> </tr> </thead> <tbody> <tr> <td>ø12 to ø25</td> <td>BQ4-012</td> </tr> <tr> <td>ø32 to ø160</td> <td>BQ5-032</td> </tr> </tbody> </table>	Bore size	Bracket	ø12 to ø25	BQ4-012	ø32 to ø160	BQ5-032				
		Bore size			Bracket													
ø12 to ø25	BQ4-012																	
ø32 to ø160	BQ5-032																	
D-A73SAPC	0,5 m	M8 (3 pin)																
Water Resistant NEW Anti-lateral Load NEW 	Magnetic field resistant auto-switch	D-P3DWL	3 wire (PNP)	In-line	3 m	—		BQ3-032S										
		D-P3DWSC			0,5 m				M8 (3 pin)									
Axial Piping (Centralised piping type) 	General purpose solid state auto-switch	D-M9BWL	2 wire	In-line	3 m	—		<table border="1"> <thead> <tr> <th>Bore size</th> <th>Bracket</th> </tr> </thead> <tbody> <tr> <td>ø12, ø16, ø20, ø25</td> <td>BQ-1</td> </tr> <tr> <td>ø20, ø25</td> <td>BQ-012</td> </tr> <tr> <td>ø32 to ø100</td> <td>BQ-2</td> </tr> <tr> <td>ø32 to ø100</td> <td>BQ-012</td> </tr> </tbody> </table> <p>Note) Two kinds of auto switch brackets are used as a set.</p>	Bore size	Bracket	ø12, ø16, ø20, ø25	BQ-1	ø20, ø25	BQ-012	ø32 to ø100	BQ-2	ø32 to ø100	BQ-012
		Bore size		Bracket														
		ø12, ø16, ø20, ø25	BQ-1															
		ø20, ø25	BQ-012															
		ø32 to ø100	BQ-2															
		ø32 to ø100	BQ-012															
	D-M9BWVL	Perpendicular	3 m	—														
	D-M9PWL	3 wire (PNP)	In-line	3 m	—													
	D-M9PWVL		Perpendicular															
	D-M9PWSAPC	3 wire (PNP)	In-line	0,5 m	M8 (3 pin)													
	D-M9PWVSAPC		Perpendicular															
	D-A93L	2 wire	In-line	3 m	—													
D-A93VL	Perpendicular																	
D-A93SAPC	In-line	0,5 m	M8 (3 pin)															
General purpose reed auto-switch	D-A73L	2 wire	Perpendicular	3 m	—	<table border="1"> <thead> <tr> <th>Bore size</th> <th>Bracket</th> </tr> </thead> <tbody> <tr> <td>ø12 to ø25</td> <td>BQ-1</td> </tr> <tr> <td>ø12, ø16, ø20, ø25</td> <td>BQ-2</td> </tr> <tr> <td>ø32 to ø100</td> <td>BQ-2</td> </tr> </tbody> </table>	Bore size	Bracket	ø12 to ø25	BQ-1	ø12, ø16, ø20, ø25	BQ-2	ø32 to ø100	BQ-2				
	Bore size			Bracket														
	ø12 to ø25	BQ-1																
	ø12, ø16, ø20, ø25	BQ-2																
ø32 to ø100	BQ-2																	
D-A73SAPC	0,5 m	M8 (3 pin)																
General purpose solid state auto-switch	D-M9BWL	2 wire	In-line	3 m	—		<table border="1"> <thead> <tr> <th>Bore size</th> <th>Bracket</th> </tr> </thead> <tbody> <tr> <td>ø20, ø25, ø63, ø80, ø100</td> <td>Not required</td> </tr> <tr> <td>ø32 to ø50</td> <td>BQ-2</td> </tr> <tr> <td>ø32 to ø50</td> <td>BQ-012</td> </tr> </tbody> </table> <p>Note) Two kinds of auto switch brackets are used as a set.</p>	Bore size	Bracket	ø20, ø25, ø63, ø80, ø100	Not required	ø32 to ø50	BQ-2	ø32 to ø50	BQ-012			
	Bore size		Bracket															
	ø20, ø25, ø63, ø80, ø100	Not required																
	ø32 to ø50	BQ-2																
	ø32 to ø50	BQ-012																
	D-M9BWVL	Perpendicular	3 m	—														
D-M9PWL	3 wire (PNP)	In-line	3 m	—														
D-M9PWVL		Perpendicular																
D-M9PWSAPC	3 wire (PNP)	In-line	0,5 m	M8 (3 pin)														
D-M9PWVSAPC		Perpendicular																
D-A93L	2 wire	In-line	3 m	—														
D-A93VL		Perpendicular																
D-A93SAPC	In-line	0,5 m	M8 (3 pin)															
General purpose reed auto-switch	D-A73L	2 wire	Perpendicular	3 m	—		<table border="1"> <thead> <tr> <th>Bore size</th> <th>Bracket</th> </tr> </thead> <tbody> <tr> <td>ø32 to ø100</td> <td>BQ-2</td> </tr> </tbody> </table>	Bore size	Bracket	ø32 to ø100	BQ-2							
	Bore size			Bracket														
ø32 to ø100	BQ-2																	
D-A73SAPC	0,5 m	M8 (3 pin)																
-XB14 Made to Order Cylinder with Heat Resistant Auto Switch How to Order CQ02 [Standard model no.] -F7NJL- XB14 Cylinder with heat resistant auto switch. Note) The body shape is the same as the existing product. *Z is not included in the model number.	Heat resistant solid state auto-switch	D-F7NJL	3-wire (NPN)	In-line	3 m	—		<table border="1"> <thead> <tr> <th>Bore size</th> <th>Bracket</th> </tr> </thead> <tbody> <tr> <td>ø16, ø20, ø25</td> <td>BQ-1</td> </tr> <tr> <td>ø32, ø40, ø50, ø63</td> <td>BQJ1-032</td> </tr> </tbody> </table>	Bore size	Bracket	ø16, ø20, ø25	BQ-1	ø32, ø40, ø50, ø63	BQJ1-032				
									Bore size	Bracket								
ø16, ø20, ø25	BQ-1																	
ø32, ø40, ø50, ø63	BQJ1-032																	

Simple Specials/Made to Order

Series CQ2

The following special specifications can be ordered as a simplified made-to-order. There is a specification sheet available on paper and CD-ROM. Please contact your SMC sales representatives if necessary.

■ Simple Specials

Symbol	Specifications	CQ2 (Standard)				CQ2 (Large Bore Size)	
		Double acting		Single acting		Double acting	
		Single rod	Double rod	Single rod/ Spring return	Single rod/ Spring extend	Single rod	Double rod
-XA1 to 30	Special rod end shape	●	●	●			

■ Made to Order

Symbol	Specifications	CQ2 (Standard)				CQ2 (Large Bore Size)	
		Double acting		Single acting		Double acting	
		Single rod	Double rod	Single rod/ Spring return	Single rod/ Spring extend	Single rod	Double rod
-XB6	Heat resistant cylinder (-10 to 150°C)	●	●				
-XB7	Cold resistant cylinder (-40 to 70°C)	●	●				
-XB9	Low-speed cylinder (10 to 50 mm/s)	●	●				
-XB10	Intermediate stroke (Exclusive body type)	●	●	●		●	●
-XB10A	Intermediate stroke (Spacer-installed type) ^{Note 3)}	●					
-XB11	Long stroke (Air-hydro type only)	●					
-XB13	Low-speed cylinder (5 to 50 mm/s)	●	●				
-XB14	Cylinder with heat resistant auto switch ^{Note 2)}	●					
-XC4	With heavy-duty scraper	●	●				
-XC6	Piston rod/Retaining ring/Rod end nut material: Stainless steel	●	●	●	●		
-XC8	Adjustable stroke cylinder/Adjustable extension type	●					
-XC9	Adjustable stroke cylinder/Adjustable retraction type	●					
-XC10	Dual stroke cylinder/Double rod	●					
-XC11	Dual stroke cylinder/Single rod	●					
-XC26	With split pins for double clevis pin/double knuckle joint pin and flat washers	●		●	●		
-XC27	Double clevis pin/Double knuckle joint pin material: Stainless steel 304	●		●	●		
-XC35	With coil scraper	●	●				
-XC36	With boss on rod side	●	●	●	●		
-X144	Special port location	●	●	●	●		
-X202	Full length dimension is the same as Series CQ1	●		●	●		
-X203	L dimension from rod cover is the same as Series CQ1	●		●	●		
-X235	Special rod end for double rod cylinder		●				●
-X271	Fluororubber seals	●	●	●	●	●	●
-X293	Full length dimension is the same as Series CQ1W		●				
-X525	Long stroke of adjustable extension stroke cylinder (-XC8)	●					
-X526	Long stroke of adjustable retraction stroke cylinder (-XC9)	●					
-X633	Intermediate stroke of double rod cylinder		●				●
-X636	Long stroke of dual stroke single rod cylinder	●					
-X1876	Cylinder tube: With concave boss on head side	●		●	●		

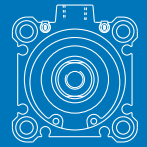

Note 1) For $\varnothing 40$ to $\varnothing 63$ only. $\varnothing 12$ to $\varnothing 32$ are available as a special product.
 Note 2) The body shape is the same as the existing product.
 Note 3) For $\varnothing 32$ to $\varnothing 100$ only.

CQ2 (Long Stroke)	CQ2K (Non-rotating Rod)		CQP2 (Axial Piping) <small>Note 2)</small>			CQ2□S (Anti-lateral Load)	CBQ2 <small>Note 2)</small> (With End Lock)
Double acting	Double acting		Double acting	Single acting		Double acting	Double acting
Single rod	Single rod	Double rod	Single rod	Single rod/ Spring return	Single rod/ Spring extend	Single rod	Single rod

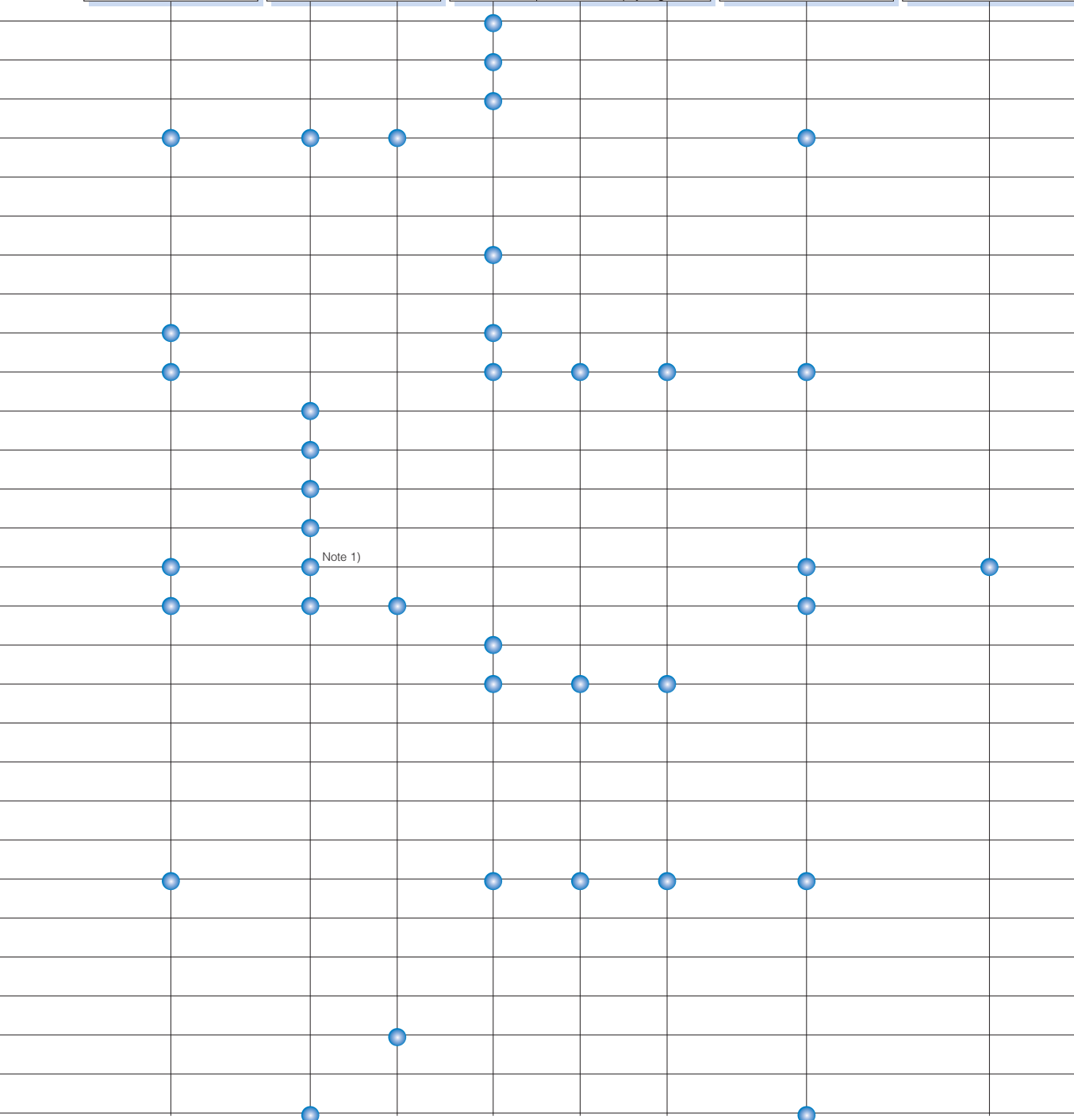

CQ2 (Long Stroke)	CQ2K (Non-rotating Rod)		CQP2 (Axial Piping)			CQ2□S (Anti-lateral Load)	CBQ2 (With End Lock)
Double acting	Double acting		Double acting	Single acting		Double acting	Double acting
Single rod	Single rod	Double rod	Single rod	Single rod/ Spring return	Single rod/ Spring extend	Single rod	Single rod

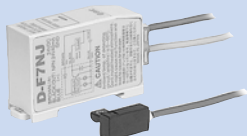
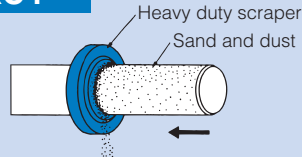
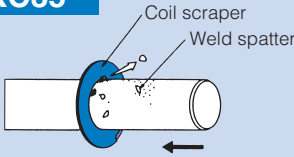

CQ2 made to order options to meet different requirements

Symbol	Details	How to order
For special environments		
-XB6	<p>Heat resistant cylinder (−10~150°C) Air cylinder in which the materials of the seals and the grease have been changed so that the cylinder can be operated at high ambient temperature of up to 150°C.</p>	<p>CQ2 CQ2W CQP2</p> <p>Standard model no. —XB6</p>
-XB7	<p>Cold resistant cylinder (−40~70°C) Air cylinder in which the materials of the seals and the grease have been changed so that the cylinder can be operated at ambient temperature as low as −40°C.</p>	<p>CQ2 CQ2W CQP2</p> <p>Standard model no. —XB7</p>
-XB14	 <p>Cylinder with heat resistant auto switch Heat resistant compact cylinder Series CDQ2 (ø16 to ø63) which can mount heat resistant solid state switch. (D-F7NJL, D-F7NJZ, Max. 150°C)</p>	<p>CDQ2</p> <p>Standard model no. —F7NJL—XB14</p>
-XC4	 <p>With heavy duty scraper As it is incorporated with a heavy duty scraper as a wiper ring, it is suitable for use in dusty area and also in earth and sand area such as casting machine, construction machine, industrial vehicle, etc.</p>	<p>C□Q2 C□QP2</p> <p>Standard model no. —XC4</p>
-XC6	<p>Piston rod, Rod end nut made of stainless steel It is suitable for rusty and/or corrosive area subject to water splashing.</p>	<p>C□Q2 C□Q2W C□QP2 C□Q2□S</p> <p>Standard model no. —XC6</p>
-XC35	 <p>With coil scraper It avoids entrance of frost, ice, weld spatter, cutting chips adhered to the piston rod, and protects the seals, etc.</p>	<p>CQ2 CQ2W CQP2</p> <p>Standard model no. —XC35</p>
-X271	<p>Fluoro rubber for seals Material for seals is changed to fluoro rubber.</p>	<p>C□Q2</p> <p>Standard model no. —X271</p>

For special speed conditions

-XB9	<p>Low speed cylinder (10~50 mm/s) Operates smoothly without sticking or slipping even at low speeds of 10~50 mm/s.</p>	<p>C□Q2 C□Q2W C□QP2</p> <p>Standard model no. —XB9</p>
-XB13	<p>Low speed cylinder (5~50 mm/s) Operates smoothly without sticking or slipping even at low speeds of 5~50 mm/s.</p>	<p>C□Q2 C□Q2W C□QP2</p> <p>Standard model no. —XB13</p>
-XB9	 <p>Smooth cylinder (Low friction)</p>	<p>C□Q2Y□□□-□DC□-□□</p>
-XB9	 <p>Low speed cylinder</p>	<p>C□Q2X□□□-□D□-□□</p>

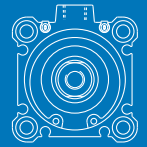

CQ2 made to order options

Symbol	Details	How to order
--------	---------	--------------

For adjusting cylinder stroke to cylinder length

-XB10 	Intermediate stroke (Using exclusive body) When using a cylinder with a non-standard intermediate stroke, this cylinder uses a special body without a spacer in order to shorten its overall dimensions and thus minimize the installation space.	C□Q2 C□Q2W C□Q2K Standard model no. - XB10 C□Q2KW C□Q2□S
-XB10A 	Intermediate stroke (Using exclusive body already in stock with an spacer)	C□Q2 Standard model no. - XB10 A
-XC8 	Adjustable stroke cylinder / Adjustable extension type A stroke adjustment mechanism is provided in the head side to adjust the extend stroke. (After the stroke is adjusted, cylinder with cushion on both sides is altered to with single-sided cushion.)	C□Q2B(H) Bore size - Stroke D(C)(M)(Z) - XC8 C□Q2K
-XC9 	Adjustable stroke cylinder / Adjustable retraction type The retract stroke of the cylinder can be adjusted by the adjusting bolt.	C□Q2B Bore size - Stroke D(M)(Z) - XC9
-XC10 	Dual stroke cylinder / Double rod type Two cylinders are constructed as one cylinder in a back-to-back configuration allowing the cylinder stroke to be controlled in three steps.	C□Q2B Bore size - Stroke S ₁ + Stroke S ₂ C□Q2K D(C)(M)(Z) - XC10
-XC11 	Dual stroke cylinder / Single rod type Two cylinders can be integrated by connecting them in line, and the cylinder stroke can be controlled in two stages in both directions.	C□Q2B Bore size - Stroke S ₁ + Stroke S ₁ - S ₂ D(C)(M)(Z) - XC11

For additional mounting possibilities and accuracy

-XA0~30 	Change of rod end shape Thirty typical diagrams are available. Fill in any special dimension you desire.	CQ2 CQ2W CQ2K Standard model no. - XA□ CQ2KW CQ2P CQ2S
-XC36 	With boss in rod side Cylinder with boss in rod side.	CQ2 CQ2W Standard model no. - XC36 CQP2
-X1876 	With concave boss on head end	C□Q2 C□Q2K Mounting Bore size - Stroke D(C)(M)(Z) S(M)(Z) - X1876 C□Q2□S T(M)(Z)
-X144 	Special port location Special port location (only for ø12 to ø25 with auto switches).	CDQ2 Standard model no. - X144□

Additional variations

CQ2□F 	With one-touch fittings	C□Q2□□□F-□□□Z
CQ2□H 	Air-hydro type	C□Q2□□H□□-□D□Z
10-, 11- 	Clean series	10-C□Q2B□-□D(M)Z 11-C□Q2B□-□D(M)Z
20- 	Copper and fluorine-free series	20-C□Q2B□-□D(C)(M)Z

■ For more information about the new CQ2 series:

To help you find the right CQ2 Cylinder for your application needs, simply check out our new **Cylinder Configurator v 2.0.(CC v2.0)**.

This user friendly configurator had been specifically developed to make the selection of standard CQ2 Cylinders, including Simple Special options and accessories, even easier than before .

To download our new CC v2.0 please go to **www.smc.eu** and click "software and downloads".

Suitable for almost all machine applications our Series CQ2 really is the most flexible compact air operated cylinder in the world.

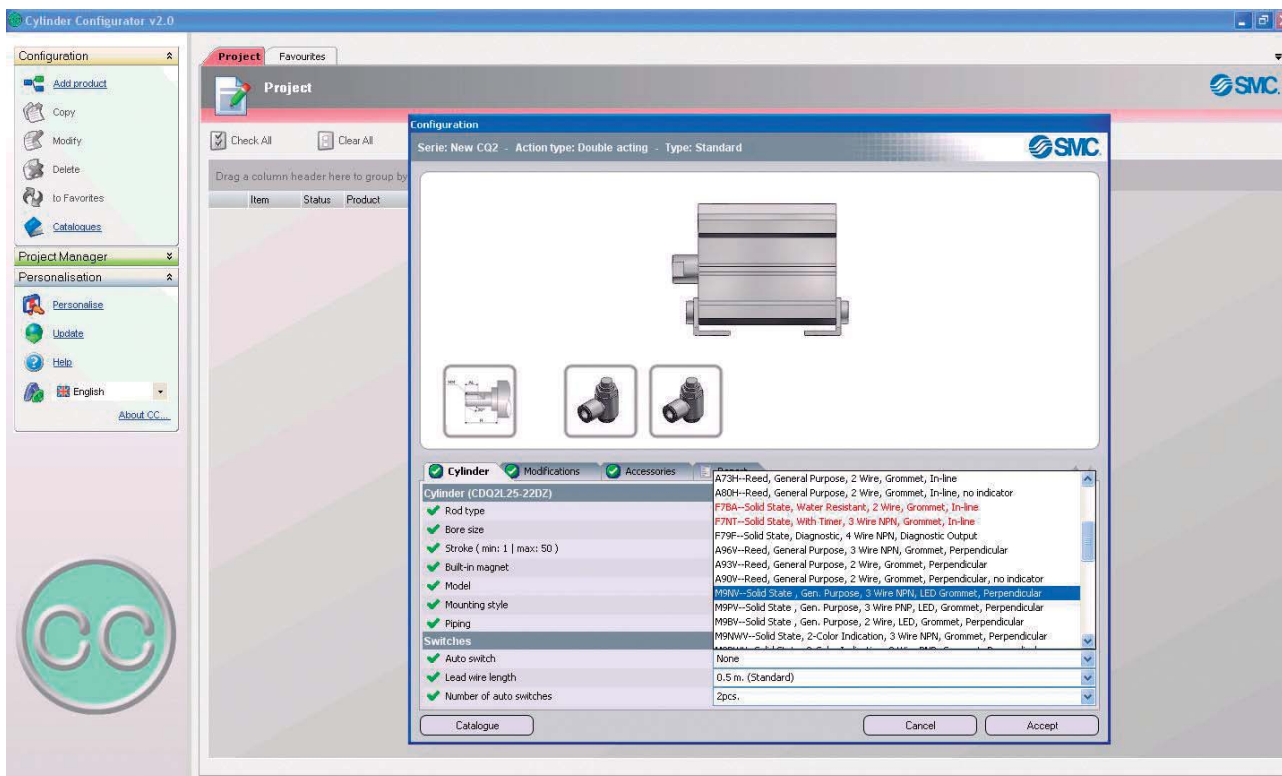

SMC CORPORATION (Europe)

CQ2-LEAF01B-UK