



PART NO.: 16-213SYGC/S530-E1/TR8

Device Number : DSE-163-007 REV. 1.0

0402 Package Chip LEDs

ECN : _____ Page: 1/8

Features :

- Package in 8mm tape on 7" diameter reel.
- Compatible with automatic placement equipment.
- Compatible with infrared and vapor phase reflow solder process.
- Mono-color type.

Descriptions :

- The 16-213 SMD Taping is much smaller than lead frame type components, thus enable smaller board size, higher packing density, reduced storage space and finally smaller equipment to be obtained.
- Besides, lightweight makes them ideal for miniature applications, etc.

Applications :

- Automotive: backlighting in dashboard and switch.
- Telecommunication: indicator and backlighting in telephone and fax.
- Flat backlight for LCD, switch and symbol.
- General use.

Package Dimensions :

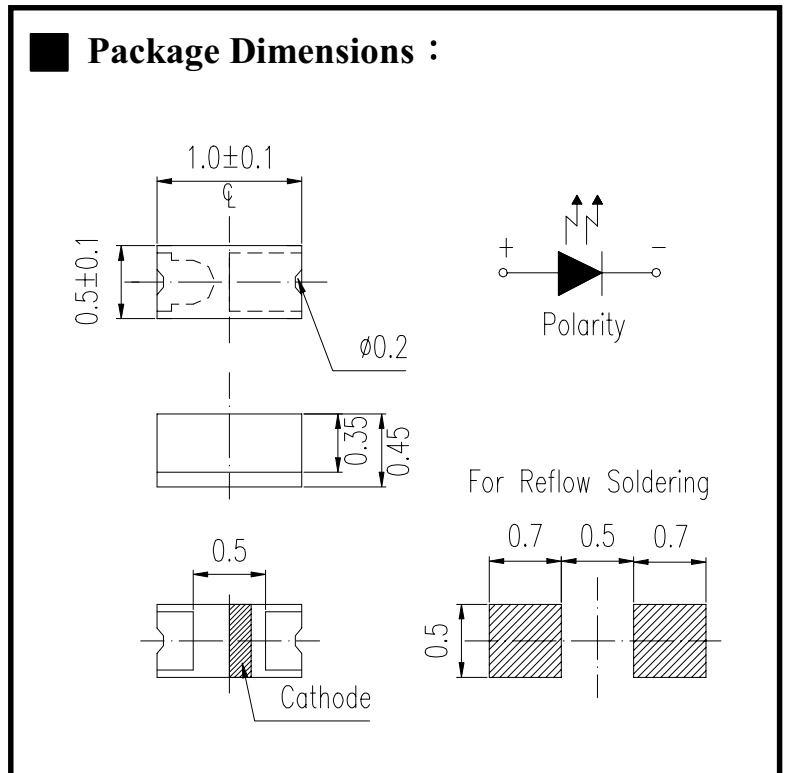

Notes :

Tolerances Unless Dimension $\pm 0.1\text{mm}$
 Angle $\pm 0.5^\circ$
 Unit = mm

PART NO.	Chip		Lens Color
	Material	Emitted Color	
16-213SYGC/S530-E1/TR8	AlGaInP	Super Yellow Green	Water Clear

Office: NO. 25, Lane 76, Sec. 3, Chung Yang Rd., Tucheng 236, Taipei, Taiwan, R.O.C.

TEL: 886-2-2267-2000, 2267-9936

FAX: 886-2-2267-6244, 2267-6189, 2267-6306

<http://www.everlight.com>



PART NO.: 16-213SYGC/S530-E1/TR8

Device Number : DSE-163-007 REV. 1.0

0402 Package Chip LEDs

ECN : _____ Page: 2/8

■ **Package Dimensions :**

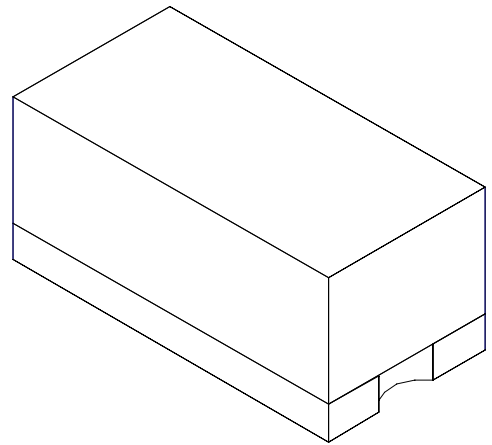
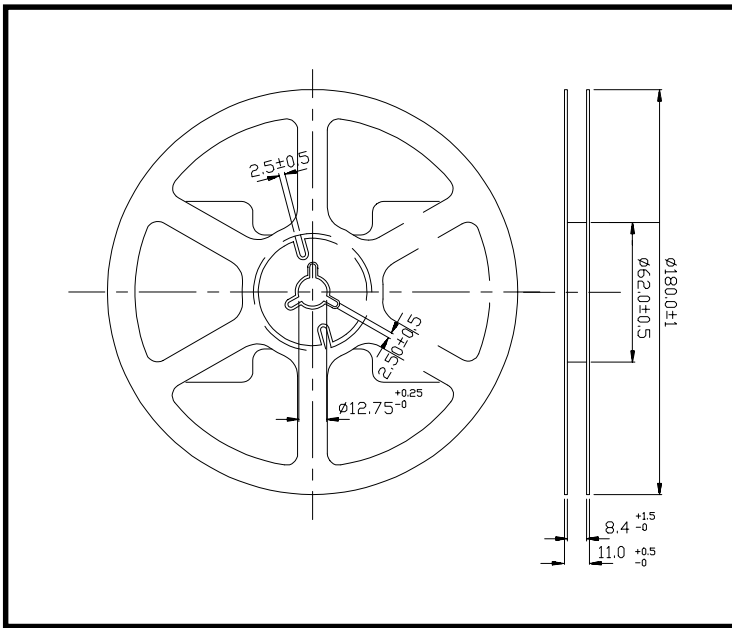

■ **Loaded quantity per reel 3000 pcs/reel :**

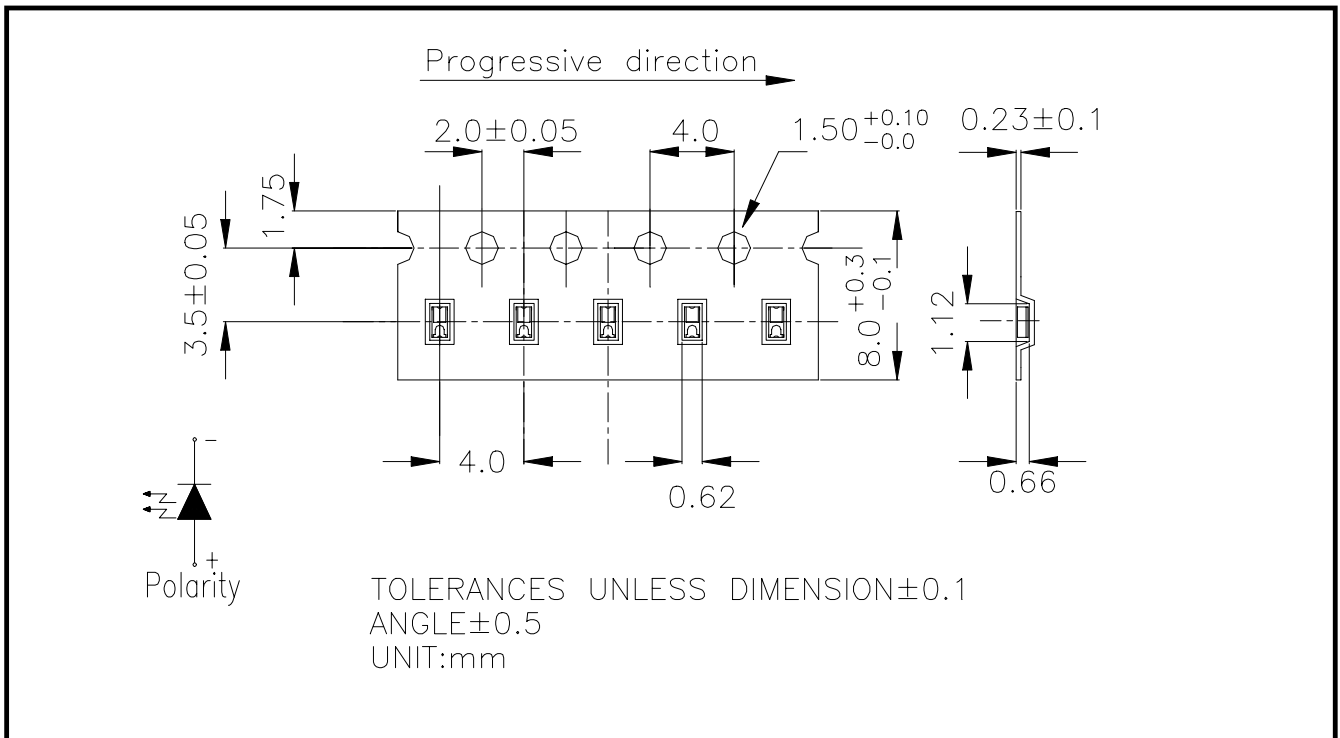



PART NO.: 16-213SYGC/S530-E1/TR8

Device Number : DSE-163-007 REV. 1.0

0402 Package Chip LEDs

ECN : _____ Page: 3/8

■ Absolute Maximum Ratings at Ta = 25°C

Parameter	Symbol	Rating	Unit
Reverse Voltage	V _R	5	V
Forward Current	I _F	25	mA
Operating Temperature	T _{opr}	-40 ~ +85	°C
Storage Temperature	T _{stg}	-40 ~ +90	°C
Soldering Temperature	T _{sol}	260 (for 5 second)	°C
Electrostatic Discharge	ESD	2000	V
Power Dissipation	P _d	60	mW
Peak Forward Current(Duty 1/10 @ 1KHz)	I _F (Peak)	160	mA

■ Electronic Optical Characteristics :

Parameter	Symbol	Min.	Typ.	Max.	Unit	Condition
Luminous Intensity	I _v	-----	1	-----	mcd	I _F =2mA
		10	15	-----	mcd	I _F =20mA
Viewing Angle	2θ 1/2	-----	120	-----	deg	I _F =20mA
Peak Wavelength	λ _p	-----	575	-----	nm	I _F =20mA
Dominant Wavelength	λ _d	-----	573	-----	nm	I _F =20mA
Spectrum Radiation Bandwidth	Δλ	-----	20	-----	nm	I _F =20mA
Forward Voltage	V _F	-----	2.0	2.4	V	I _F =20mA
Reverse Current	I _R	-----	-----	10	μA	V _R =5V



PART NO.: 16-213SYGC/S530-E1/TR8

Device Number : DSE-163-007 REV. 1.0

0402 Package Chip LEDs

ECN : _____ Page: 4/8

■ Reliability Test Items And Conditions:

NO	Item	Test Conditions	Test Hours/Cycle	Sample Size	Ac/Re
1	Solder Heat	TEMP : 260°C ± 5 °C	5 SEC	76 PCS	0/1
2	Temperature Cycle	H : +85°C 30min ∩ 5 min L : -55°C 30min	50 CYCLE	76 PCS	0/1
3	Thermal Shock	H : +100°C 5min ∩ 10 sec L : -10°C 5min	50 CYCLE	76 PCS	0/1
4	High Temperature Storage	TEMP : 100°C	1000 HRS	76 PCS	0/1
5	Low Temperature Storage	TEMP : -55°C	1000 HRS	76 PCS	0/1
6	DC Operating Life	I _F = 20 mA	1000 HRS	76 PCS	0/1
7	High Temperature / High Humidity	85°C/RH85%	1000 HRS	76 PCS	0/1



PART NO.: 16-213SYGC/S530-E1/TR8

Device Number : DSE-163-007 REV. 1.0

0402 Package Chip LEDs

ECN : _____ Page: 5/8

Typical Electro-Optical Characteristic Curves

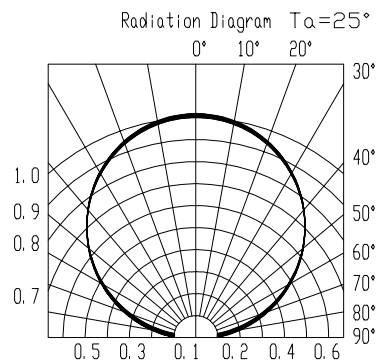
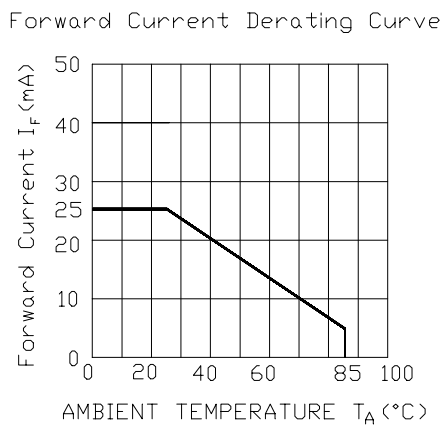
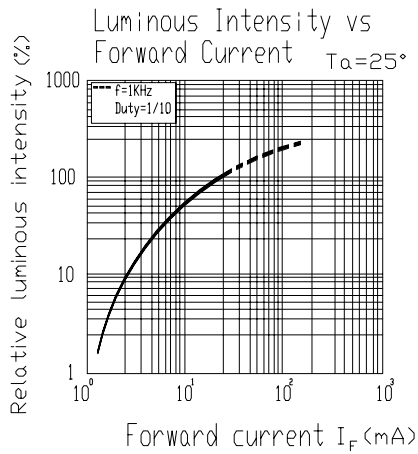
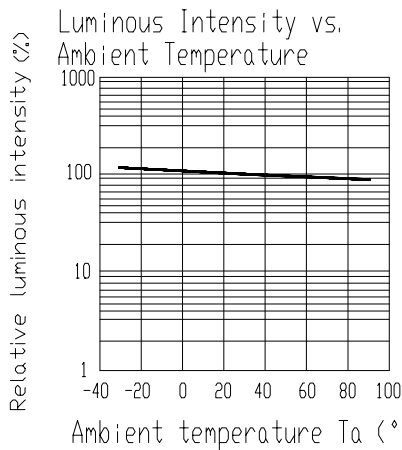
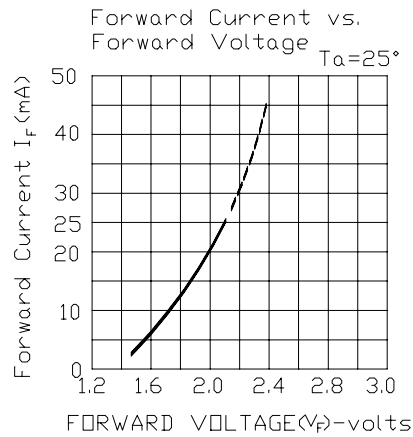
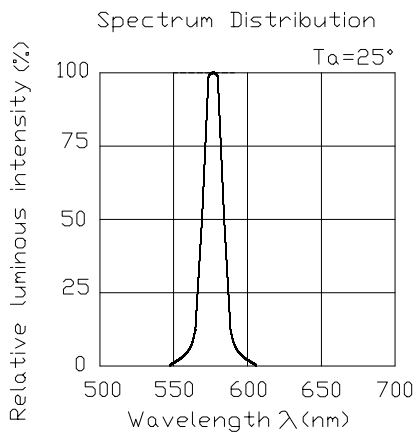



PART NO.: 16-213SYGC/S530-E1/TR8

Device Number : DSE-163-007 REV. 1.0

0402 Package Chip LEDs

ECN : _____ Page: 6/8

■ Test Circuit

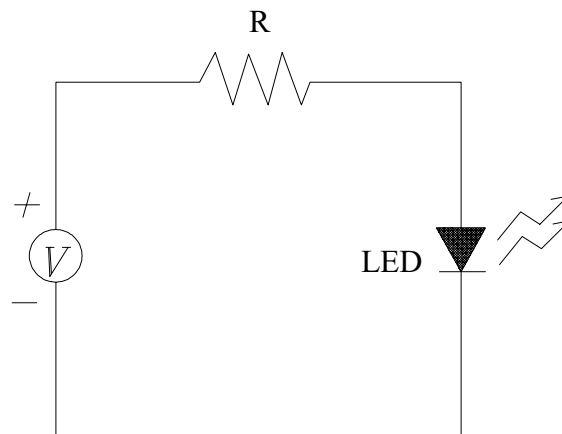

■ Precautions For Use

1. Over-current-proof

Customer must apply resistors for protection , otherwise slight voltage shift will cause big current change (Burn out will happen).

2. Storage time

2.1 The operation of temperature and R.H. are : $5^{\circ}\text{C}\sim 35^{\circ}\text{C}$, R.H.60%.

2.2 Once the package is opened, the products should be used within a week.

Otherwise, they should be keeping in a damp proof box with desiccating agent.

Considering the tape life , we suggest our customers to use our products within a year(from production date).

2.3 If opened more than one week in an atmosphere $5^{\circ}\text{C}\sim 35^{\circ}\text{C}$, R.H.60%, they should be treated at $60^{\circ}\text{C}\pm 5^{\circ}\text{C}$ for 15hrs.

2.4 When you discover that the desiccant in the package has a pink color (normal = blue) , you should treat them in the same conditions as 2.3.

PART NO.: 16-213SYGC/S530-E1/TR8
0402 Package Chip LEDs

Device Number : DSE-163-007 REV. 1.0

ECN : _____ Page: 7/8

■ **Soldering heat reliability (DIP)**

Please refer to the following figure :

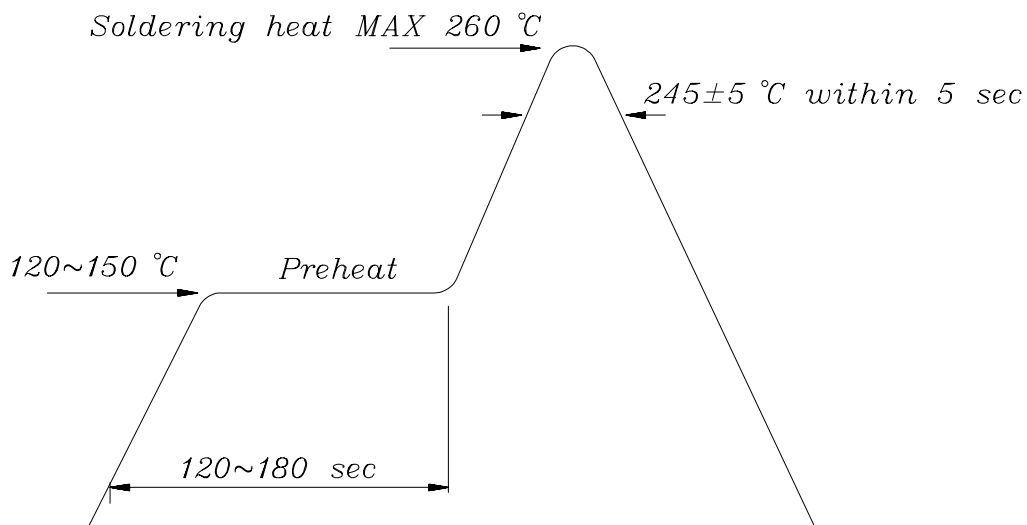

■ **Soldering Iron**

Basic spec is ≤ 5 sec when 260°C . If temperature is higher, time should be shorter ($+10^{\circ}\text{C} \rightarrow -1\text{sec}$). Power dissipation of iron should be smaller than 15 W , and temperature should be controllable. Surface temperature of the device should be under 230°C .

■ **Rework**

1. Customer must finish rework within 5 sec under 260°C .
2. The head of iron can not touch copper foil.
3. Twin-head type is preferred.

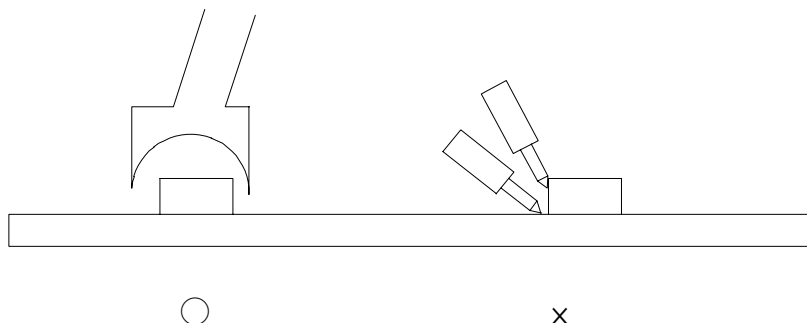



PART NO.: 16-213SYGC/S530-E1/TR8

Device Number : DSE-163-007 REV. 1.0

0402 Package Chip LEDs

ECN : _____ Page: 8/8

■ Reflow Temp. / Time :

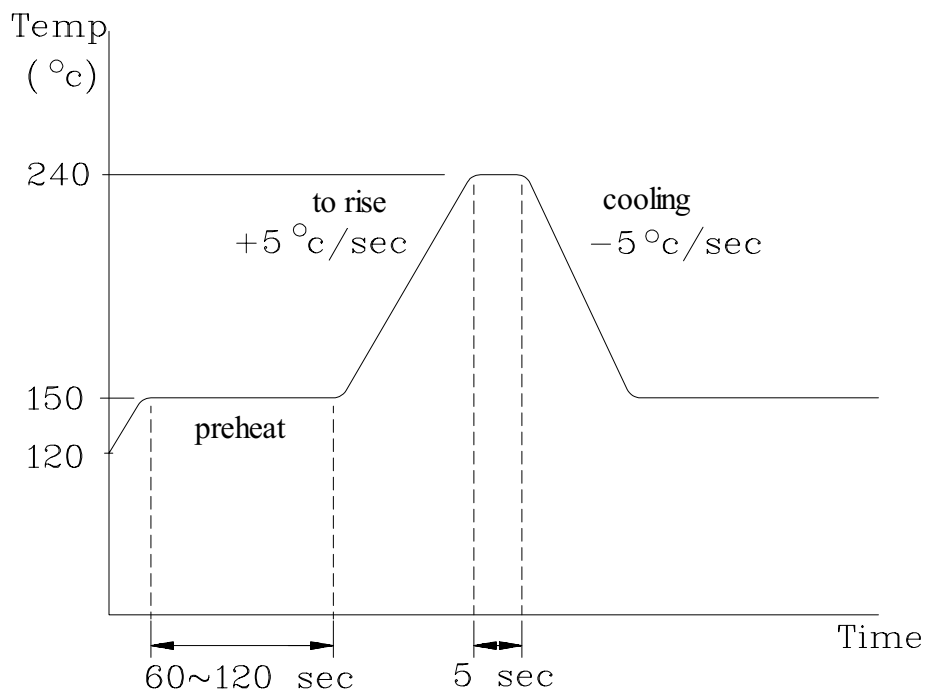

■ Thickness of tin paste :

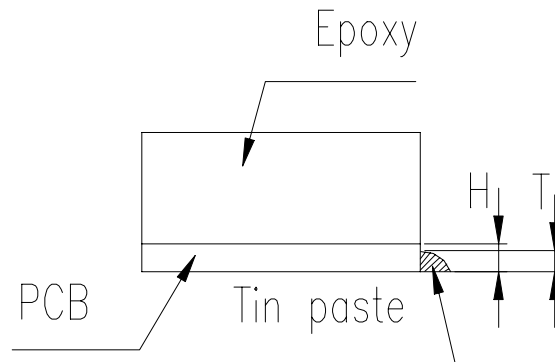

Thickness:
 $1/2H < T < H$