

Switch block , 1NO1NC

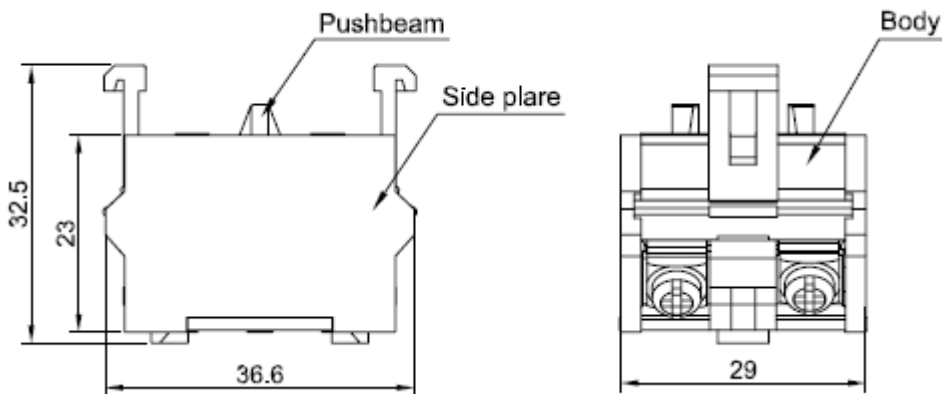

6 MAX: means the panel thickness, the max thickness for the panel no more than 6mm.

Specification	1NO1NC Switch block
Connection	Screw
Contact structure	1NO1NC
Contact material	PC
Mechanical life	500,000 times
Electrical life	50,000 times
Switch rating	250VAC / 5A
Operating and storage temperature	-20 to +55 °C
Operating and storage humidity	45 to 85 % RH

This is a publication by Conrad Electronic SE, Klaus-Conrad-Str. 1, D-92240 Hirschau (www.conrad.com).

All rights including translation reserved. Reproduction by any method, e.g. photocopy, microfilming, or the capture in electronic data processing systems require the prior written approval by the editor. Reprinting, also in part, is prohibited. This publication represents the technical status at the time of printing.

© Copyright 2017 by Conrad Electronic SE.