

GN 278 | Pivoting connecting clamps

Aluminium



- 1
- 2
- 3
- 4
- 5
- 6
- 7
- 8
- 9
- 10
- 11
- 12
- 13
- 14
- 15
- 16
- 17
- 18

MATERIAL

Aluminium, matte finish.
AISI 304 stainless steel screws and nuts.

STANDARD EXECUTIONS

- **GN 278-BL-OZ**: natural aluminium.
- **GN 278-BL-MZ**: natural aluminium, with embossed centering ring.
- **GN 278-BL-AV**: natural aluminium, with embossed toothing.
- **GN 278-BL-IV**: natural aluminium, with flush toothing.
- **GN 278-SW-OZ**: aluminium, epoxy resin coating, RAL 9005 black colour.
- **GN 278-SW-MZ**: aluminium, epoxy resin coating, RAL 9005 black colour, with embossed centering ring.
- **GN 278-SW-AV**: aluminium, epoxy resin coating, RAL 9005 black colour, with embossed toothing.
- **GN 278-SW-IV**: aluminium, epoxy resin coating, RAL 9005 black colour, with flush toothing.



FEATURES AND APPLICATIONS

The assembly hole of GN 278 connecting clamps allows an excellent match with tubes GN 990 (see page 1778).

GN 278 connecting clamps can be assembled with connecting clamps GN 272 (see page 1752), GN 274 (see page 1754) or GN 276 (see page 1758).

The clamping screws d_3 may be replaced by clamping kits GN 911 (see page 1782).

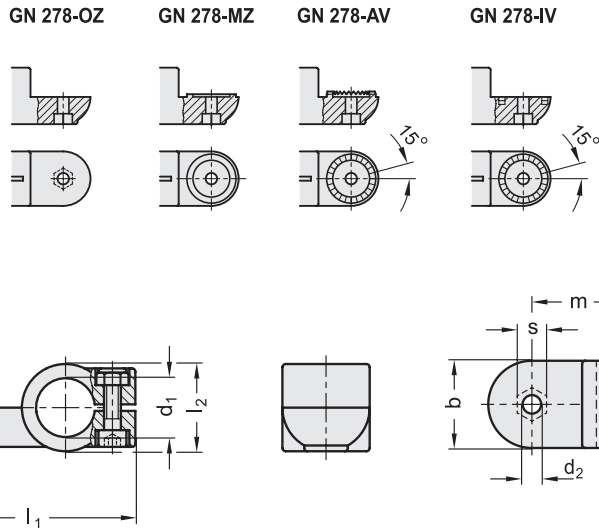

GN 278-BL-OZ GN 278-SW-OZ

Code BL	Code SW	Description	b	d1	d2	d3	d4	k	l1	l2	m	t	s	d3 Clamping kit	Δ
GN.60271	GN.60276	GN 278-B20-OZ-2-*	40	20	8.5	M8	M8	40	95	40	43	20	13	GN 911-M8-32	185
GN.60351	GN.60356	GN 278-B25-OZ-2-*	40	25	8.5	M8	M8	40	95	40	43	20	13	GN 911-M8-32	170
GN.60431	GN.60436	GN 278-B30-OZ-2-*	40	30	8.5	M8	M8	40	95	40	43	20	13	GN 911-M8-32	145
GN.60511	GN.60516	GN 278-B40-OZ-2-*	65	40	10.5	M10	M10	65	148	65	70	32.5	17	GN 911-M10-55	705
GN.60591	GN.60596	GN 278-B42-OZ-2-*	65	42	10.5	M10	M10	65	148	65	70	32.5	17	GN 911-M10-55	675
GN.60671	GN.60676	GN 278-B45-OZ-2-*	65	45	10.5	M10	M10	65	148	65	70	32.5	17	GN 911-M10-55	645
GN.60751	GN.60756	GN 278-B48-OZ-2-*	65	48	10.5	M10	M10	65	148	65	70	32.5	17	GN 911-M10-55	610
GN.60831	GN.60836	GN 278-B50-OZ-2-*	65	50	10.5	M10	M10	65	148	65	70	32.5	17	GN 911-M10-55	585

* Complete the description of the standard item needed by adding the finish of the connector clamps: BL (blank) or SW (black).

**GN 278-BL-MZ GN 278-SW-MZ**

Code BL	Code SW	Description	b	d1	d2	d3	d4	k	l1	l2	m	t	s	d3 Clamping kit	
GN.60251	GN.60256	GN 278-B20-MZ-2-*	40	20	8.5	M8	M8	40	95	40	43	20	13	GN 911-M8-32	185
GN.60331	GN.60336	GN 278-B25-MZ-2-*	40	25	8.5	M8	M8	40	95	40	43	20	13	GN 911-M8-32	170
GN.60411	GN.60416	GN 278-B30-MZ-2-*	40	30	8.5	M8	M8	40	95	40	43	20	13	GN 911-M8-32	145
GN.60491	GN.60496	GN 278-B40-MZ-2-*	65	40	10.5	M10	M10	65	148	65	70	32.5	17	GN 911-M10-55	695
GN.60571	GN.60576	GN 278-B42-MZ-2-*	65	42	10.5	M10	M10	65	148	65	70	32.5	17	GN 911-M10-55	675
GN.60651	GN.60656	GN 278-B45-MZ-2-*	65	45	10.5	M10	M10	65	148	65	70	32.5	17	GN 911-M10-55	645
GN.60731	GN.60736	GN 278-B48-MZ-2-*	65	48	10.5	M10	M10	65	148	65	70	32.5	17	GN 911-M10-55	605
GN.60811	GN.60816	GN 278-B50-MZ-2-*	65	50	10.5	M10	M10	65	148	65	70	32.5	17	GN 911-M10-55	575

GN 278-BL-AV GN 278-SW-AV

Code BL	Code SW	Description	b	d1	d2	d3	d4	k	l1	l2	m	t	s	d3 Clamping kit	
GN.60211	GN.60216	GN 278-B20-AV-2-*	40	20	8.5	M8	M8	40	95	40	43	20	13	GN 911-M8-32	190
GN.60291	GN.60296	GN 278-B25-AV-2-*	40	25	8.5	M8	M8	40	95	40	43	20	13	GN 911-M8-32	170
GN.60371	GN.60376	GN 278-B30-AV-2-*	40	30	8.5	M8	M8	40	95	40	43	20	13	GN 911-M8-32	150
GN.60451	GN.60456	GN 278-B40-AV-2-*	65	40	10.5	M10	M10	65	148	65	70	32.5	17	GN 911-M10-55	690
GN.60531	GN.60536	GN 278-B42-AV-2-*	65	42	10.5	M10	M10	65	148	65	70	32.5	17	GN 911-M10-55	675
GN.60611	GN.60616	GN 278-B45-AV-2-*	65	45	10.5	M10	M10	65	148	65	70	32.5	17	GN 911-M10-55	640
GN.60691	GN.60696	GN 278-B48-AV-2-*	65	48	10.5	M10	M10	65	148	65	70	32.5	17	GN 911-M10-55	600
GN.60771	GN.60776	GN 278-B50-AV-2-*	65	50	10.5	M10	M10	65	148	65	70	32.5	17	GN 911-M10-55	580

GN 278-BL-IV GN 278-SW-IV

Code BL	Code SW	Description	b	d1	d2	d3	d4	k	l1	l2	m	t	s	d3 Clamping kit	
GN.60231	GN.60236	GN 278-B20-IV-2-*	40	20	8.5	M8	M8	40	95	40	43	20	13	GN 911-M8-32	180
GN.60311	GN.60316	GN 278-B25-IV-2-*	40	25	8.5	M8	M8	40	95	40	43	20	13	GN 911-M8-32	160
GN.60391	GN.60396	GN 278-B30-IV-2-*	40	30	8.5	M8	M8	40	95	40	43	20	13	GN 911-M8-32	140
GN.60471	GN.60476	GN 278-B40-IV-2-*	65	40	10.5	M10	M10	65	148	65	70	32.5	17	GN 911-M10-55	685
GN.60551	GN.60556	GN 278-B42-IV-2-*	65	42	10.5	M10	M10	65	148	65	70	32.5	17	GN 911-M10-55	665
GN.60631	GN.60636	GN 278-B45-IV-2-*	65	45	10.5	M10	M10	65	148	65	70	32.5	17	GN 911-M10-55	620
GN.60711	GN.60716	GN 278-B48-IV-2-*	65	48	10.5	M10	M10	65	148	65	70	32.5	17	GN 911-M10-55	585
GN.60791	GN.60796	GN 278-B50-IV-2-*	65	50	10.5	M10	M10	65	148	65	70	32.5	17	GN 911-M10-55	565

* Complete the description of the standard item needed by adding the finish of the connector clamps: BL (blank) or SW (black).