

### Bottom View of Assembly

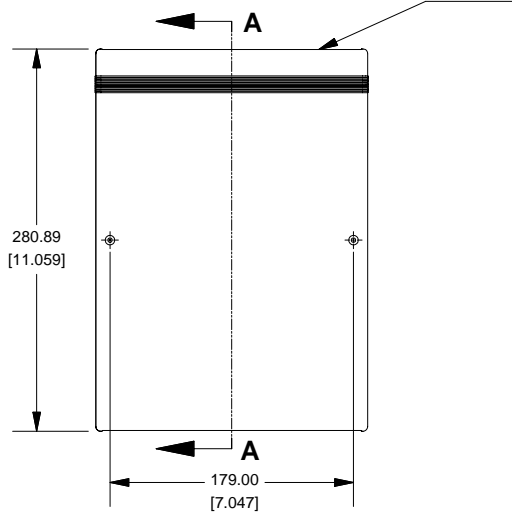

### SECTION A-A (Side View Inside Assembly)

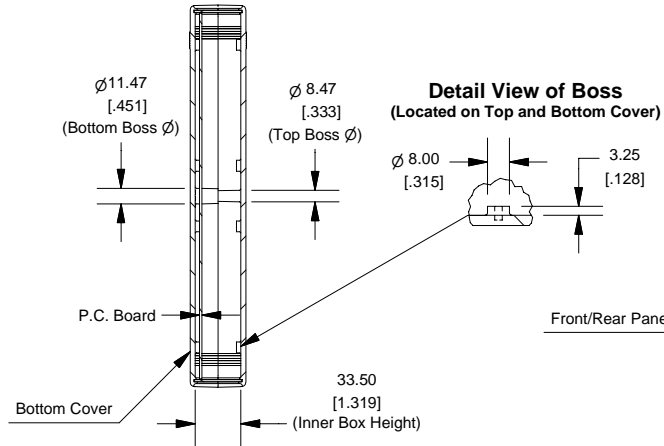

### Instrument (1598H)

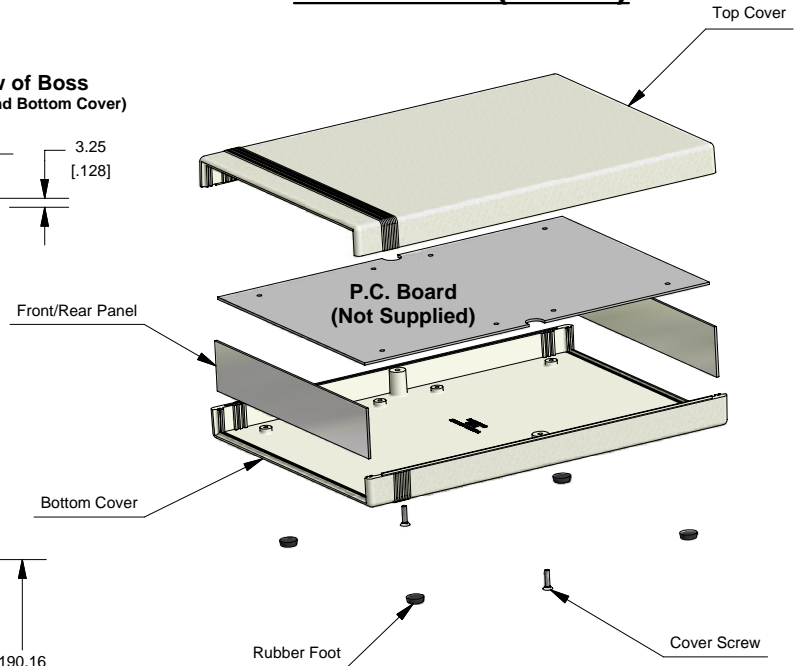

### End View of Assembly

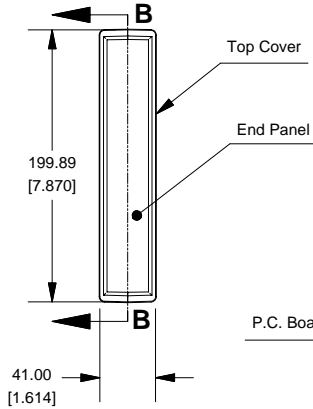

### SECTION B-B (Inside of Bottom Cover)

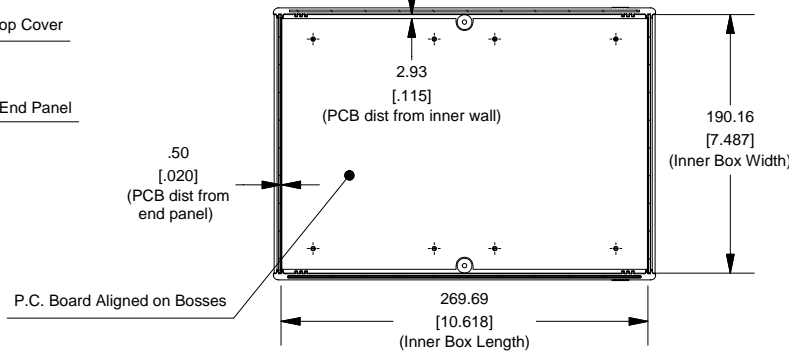

### Front/Rear Panel (Dashed Line Indicates Viewing Area)

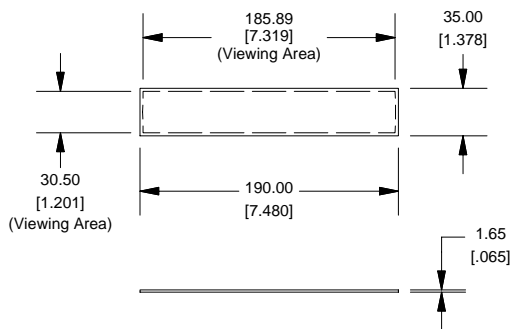

### Maximum P.C. Board Size

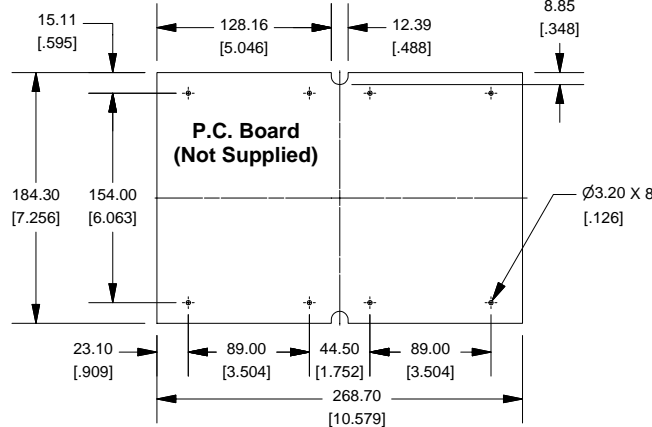

**NOTE**  
Purchased assembly includes top and bottom cover, front and end aluminum panels (type 5005H32, SPV coating on one side), 2 cover screws, and 4 rubber feet.

PART NUMBERS		
1598H- Polystyrene (UL94-HB)		
Grey Enclosure with Aluminum Panels 1598HSGY	Grey Enclosure with Black Plastic Panels 1598HSGYPBK	Black EMI/RFI Shielded --
1598H - Flame Retardant ABS (UL94-VO)		
Black Enclosure with Aluminum Panels 1598HBK	Grey Enclosure with Aluminum Panels 1598HGY	Black EMI/RFI Shielded 1598RHBK
Accessories		Rubber Feet (Pkg 24)
Black Plastic Panels (Optional) 1598PLHBK		1421T3
For 1598 Polystyrene Cover Screws (Pkg 100) [#4 x 5/8" (15.9mm)] 1598TS100	For 1598 FR-ABS Cover Screws (Pkg 100) [M3 - 0.5" x 10mm] 1591MS100	Both Models P.C. Board Screws (Pkg 100) [#6 x 1/4" (6.4mm)] 1598ATS100

