

- 1
- 2
- 3
- 4
- 5
- 6
- 7
- 8
- 9
- 10
- 11
- 12
- 13
- 14
- 15
- 16
- 17
- 18

MATERIAL

High-resistance reinforced phenolic based (PF) Duroplast, black colour, glossy finish.

STANDARD EXECUTIONS

Black-oxide steel hub.

- **VDC-GXX**: for gravity indicators.

Solid hub, see table for maximum permissible boring diameters d' and d'' .

- **VDC-GXX+I**: for gravity indicators.

Solid hub, see table for maximum permissible boring diameters d' and d'' .
Revolving handle I.301+x (see page 574) in Duroplast, black colour, glossy finish.

- **VDC-PXX+I**: for positive drive indicators.

Rear flange with internal crown gear wheel in acetal resin based (POM) technopolymer. Black-oxide steel screw and anchor pin.

Hub with H7 reamed through hole.

Revolving handle I.301+x (see page 574) in Duroplast, black colour, glossy finish.

ERGONOMY

The rim with internal rear scallops (for models with diameter $D \geq 125$ mm) makes the grip and the manoeuvre of the handwheel easier especially in the versions without handle.

INDICATOR CHOICE (TO BE ORDERED SEPARATELY)

To choose the indicator see the table below for possible assembly with indicators.

See also "Assembly instructions" for gravity indicators type G (on page 632) or positive drive indicators type P (on page 634).



ELESA Original design

VDC-GXX

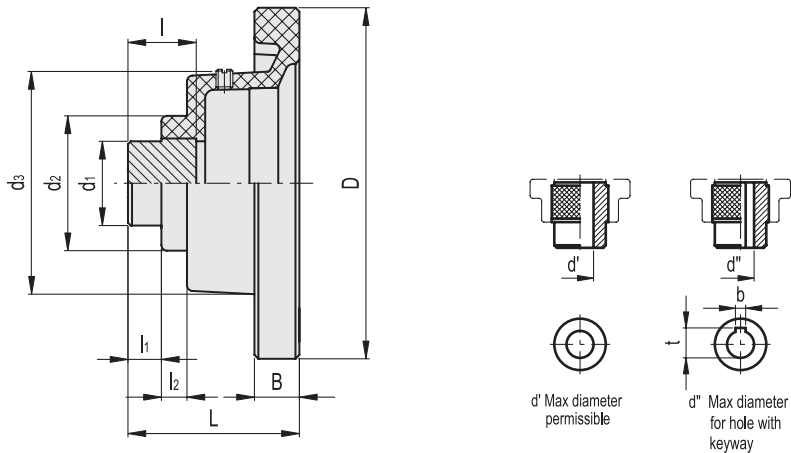

VDC-GXX

Code	Description	D	L	d'	d''	t	b	d1	d2	d3	l	l1	l2	B	⚖️	Handwheel/indicator combinations
CE.30501	VDC.125-GXX2	125	61	25	20	22.8	6	30	48	82	25	12	9	16	400	GA02 - GA12 - GW12
CE.30601	VDC.140-GXX2	140	65	25	20	22.8	6	30	50	82	25	12	9	17	470	GA02 - GA12 - GW12
CE.30701	VDC.160-GXX2	160	72	30	24	27.3	8	35	53	84	30	15	10	18	650	GA02 - GA12 - GW12
CE.30901	VDC.160-GXX5	160	71	31	25	28.3	8	36	53	123	34	14	11	18	730	GA05
CE.31001	VDC.180-GXX5	180	78	31	25	28.3	8	36	56	127	34	14	12	19	940	GA05
CE.31101	VDC.200-GXX5	200	79	35	29	32.3	8	40	59	127	34	13	15	20	1080	GA05

VDC-GXX+I

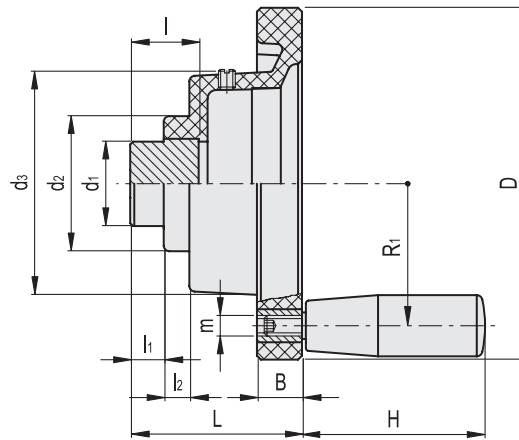

VDC-GXX+I

Code	Description	D	L	d'	d''	t	b	d1	d2	d3	l	l1	l2	B	H	m	R1	⚖	Handwheel/indicator combinations
CE.30461	VDC.80-GXX1+I	87	57	20	16	18.3	5	25	40	58	23	11	8.5	14	40	M6	34.5	245	GA01 - GA11
CE.30481	VDC.100-GXX2+I	108	60	25	20	22.8	6	30	46	79	25	12	9.5	14	50	M6	45	375	GA02 - GA12 - GW12
CE.30511	VDC.125-GXX2+I	125	61	25	20	22.8	6	30	48	82	25	12	9	16	65	M8	53	480	GA02 - GA12 - GW12
CE.30611	VDC.140-GXX2+I	140	65	25	20	22.8	6	30	50	82	25	12	9	17	65	M8	60	540	GA02 - GA12 - GW12
CE.30711	VDC.160-GXX2+I	160	72	30	24	27.3	8	35	53	84	30	15	10	18	80	M8	68	750	GA02 - GA12 - GW12
CE.30811	VDC.180-GXX2+I	180	78	30	24	27.3	8	35	56	85	30	15	10	19	80	M10	77.5	890	GA02 - GA12 - GW12
CE.30911	VDC.160-GXX5+I	160	71	31	25	28.3	8	36	53	123	34	14	11	18	80	M8	68	825	GA05
CE.31011	VDC.180-GXX5+I	180	78	31	25	28.3	8	36	56	127	34	14	12	19	80	M10	77.5	1010	GA05
CE.31111	VDC.200-GXX5+I	200	79	35	29	32.3	8	40	59	127	34	13	15	20	80	M10	87	1180	GA05

VDC-PXX+I

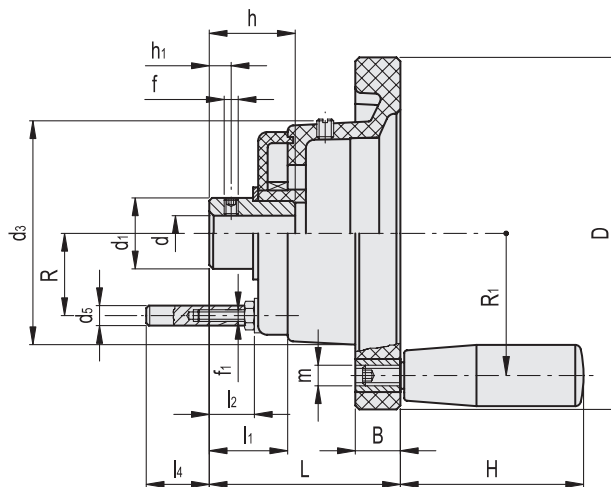

VDC-PXX+I

Code	Description	D	L	dH7	h	d1	d3	d5	f	f1	h1	l1	l2	l4	B	H	m	R	R1	⚖	Handwheel/indicator combinations
CE.30462	VDC.80-PXX1+I A-8	87	57	8	23	18	58	6	M5	M4	5	19	11	14.1	14	40	M6	19	34.5	230	PA01 - PA11
CE.30482	VDC.100-PXX2+I A-10	108	60	10	25	30	78	6	M5	M4	6	21	13	12.1	14	50	M6	28.5	45	390	PA02 - PA12 - PW12

- 1
- 2
- 3
- 4
- 5
- 6
- 7
- 8
- 9
- 10
- 11
- 12
- 13
- 14
- 15
- 16
- 17
- 18