

# I17001

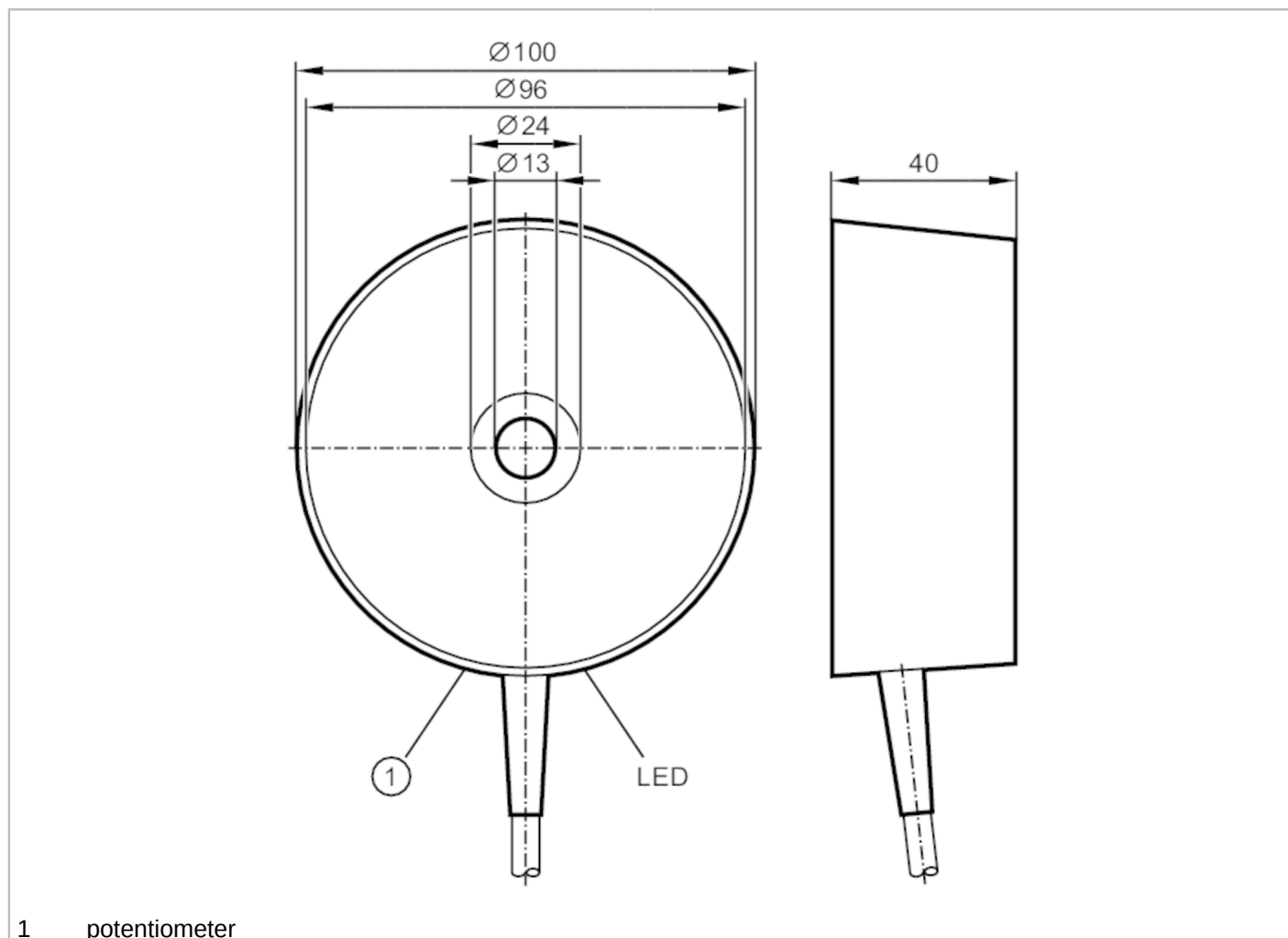

## Inductive area sensor

SIT-3070-BPKG



1 potentiometer



### Product characteristics

Electrical design		PNP
Output function		normally open
Sensing range	[mm]	20...70
Housing		cylindrical
Dimensions	[mm]	Ø 100 / L = 40

### Electrical data

Operating voltage	[V]	10...36 DC
Current consumption	[mA]	15; (24 V)
Protection class		II
Reverse polarity protection		yes

# I17001



## Inductive area sensor

SIT-3070-BPKG

Outputs		
Electrical design		PNP
Output function		normally open
Max. voltage drop switching output DC	[V]	2.5
Permanent current rating of switching output DC	[mA]	250
Switching frequency DC	[Hz]	5
Short-circuit protection		yes
Type of short-circuit protection		pulsed
Overload protection		yes
Detection zone		
Sensing range	[mm]	20...70
Sensing range adjustable		yes
Factory setting sensing range	[mm]	70
Real sensing range Sr	[mm]	70 ± 10 %
Accuracy / deviations		
Correction factor		steel: 1 / stainless steel: 0.7 / brass: 0.4 / aluminium: 0.4 / copper: 0.3
Hysteresis	[% of Sr]	< 15
Switch point drift	[% of Sr]	-15...15
Operating conditions		
Ambient temperature	[°C]	-20...70
Protection		IP 65
Tests / approvals		
EMC	EN 60947-5-2	
	EN 55011	class B
MTTF	[years]	724
Mechanical data		
Weight	[g]	516.5
Housing		cylindrical
Mounting		non-flush mountable
Dimensions	[mm]	Ø 100 / L = 40
Materials		PBT
Displays / operating elements		
Display	switching status	1 x LED, yellow
Accessories		
Accessories (supplied)		screws: 1
Remarks		
Pack quantity		1 pcs.

# I17001



## Inductive area sensor

SIT-3070-BPKG

### Electrical connection

Cable: 2 m, PVC; 3 x 0.5 mm<sup>2</sup>

### Connection

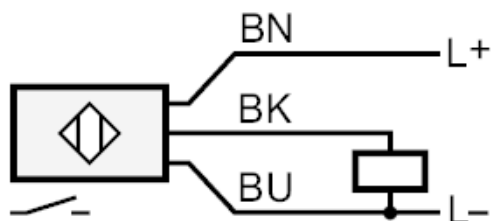

Core colours :

BK =

black

BN =

brown

BU =

blue