

Sencera Co. Ltd. Data Sheet

Tel:886-2-27046595 Fax:886-2-27041279 Email: justinel@ms14.hinet.net

4F-1, No. 26, Sec. 3, Jen-Ai road, Taipei, Taiwan, ROC. <http://welcome.to/sencera>

HS-130AS Alcohol sensor

- High sensitivity
- Quick response
- Low power consumption
- High quality and long term stable

Structure

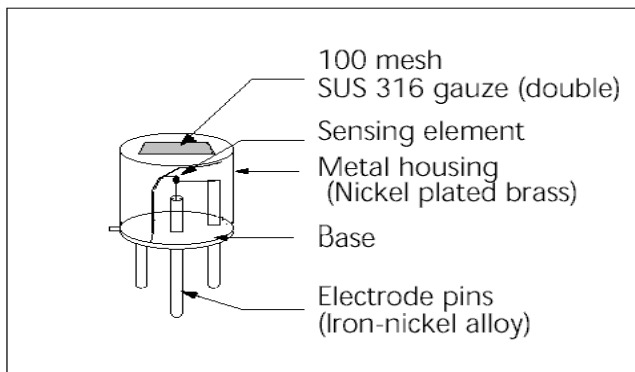

Fig 1a. Configuration

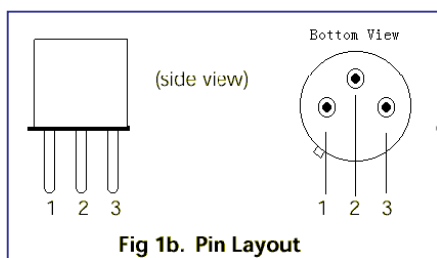

Fig 1b. Pin Layout

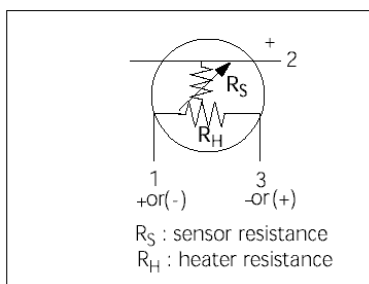

Fig 1c. Equivalent circuit

Structure and Dimensions:

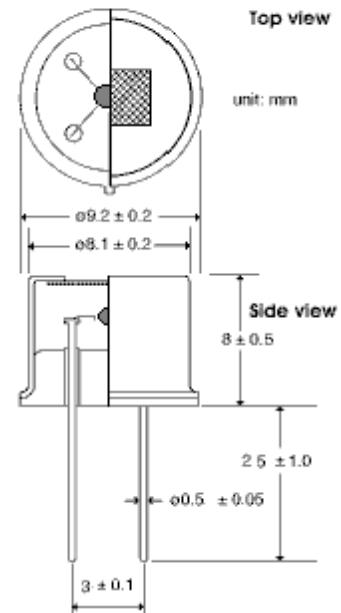

Fig 1d.

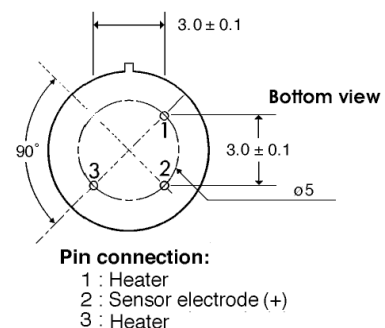

Fig. 1e

HS130AS semiconductor type alcohol sensor element is a mini type which picture and dimension please refer Fig 1a and Fig. 1b, Fig. 1c, Fig. 1d. Fig. 1e.

Operating conditions

Fig 2 shows the standard operating circuit . The sensor resistance (R_S) will be get from the different of the output voltage or variable resistor (R_L). In order to obtain the best performance and specified characteristics, the values of the heater voltage (V_H), circuit voltage (V_C) and load resistance (R_L) must be operated in the standard conditions shown in the next page of specification table.

Sensitivity characteristics

Fig 3 shows the sensitivity characteristics curves of the HS-130AS (typical data). Sensitivity characteristics of the element are expressed by the relationship between the sensor resistance and alcohol gas concentration. The sensor resistance will be decreases if increase alcohol gas concentration.

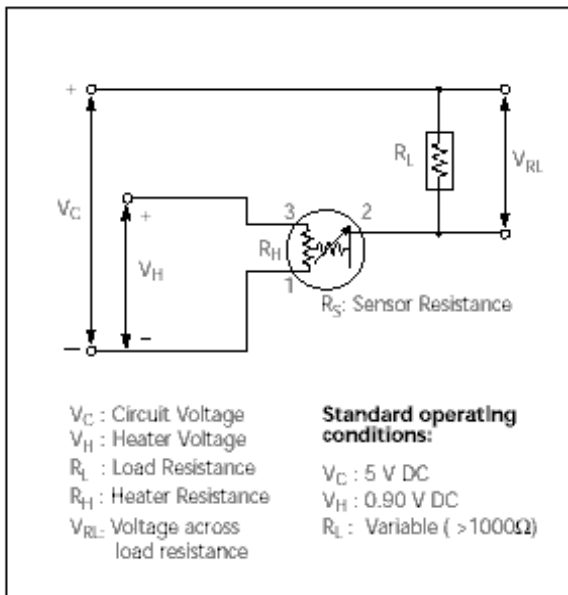

Fig 2. Standard circuit

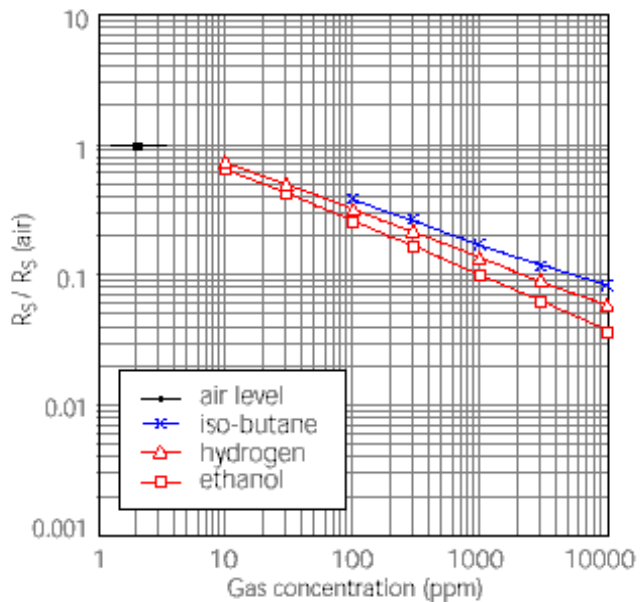

Fig 3. Sensitivity characteristics

A. Standard Operating conditions

Symbol	Parameter	Specification	Conditions etc.
V_H	Heater voltage	0.90V \pm 0.05V	AC or DC
V_C	Circuit voltage	Less than 5 V	DC (polarity is important)
R_L	Load resistance	Variable (> 10 K Ω)	$P_S < 10$ mW
R_H	Heater resistance	2.8 Ω \pm 0.5 Ω	at room temperature
I_H	Heater current	Less than 130 mA	$I_H = V_H / R_H$ (typical value)
P_H	Heater power consumption	120 mW	$P_H = V_H^2 / R_H$ (typical value)
P_S	Power dissipation of sensing element	Less than 10 mW	$P_S = (V_C - V_{RL})^2 / R_S$

B. Environmental conditions

Symbol	Parameter	Specification	Conditions etc.
Tao	Operating temperature	-20 ° C to +50 ° C	Recommended range
Tas	Storage temp	-20 ° C to +70 ° C	
RH	Relative humidity	Less than 95% RH	
(O2)	Oxygen concentration	21% ± 1%(Standard condition)	Absolute minimum level: more then 18%
		The sensitivity characteristics will be changed by the different oxygen concentration.	

C. Sensitivity characteristics

Model	HS-303A (reference specifications)		
Symbol	Parameter	Specification	Conditions etc.
R _s	Sensor resistance	(10kΩ to 100 kΩ)	at ethanol 300 ppm
β	Sensitivity	(0.50 ± 0.15)	Rs (at ethanol 300 ppm) / Rs (at ethanol 50 ppm)
Standard Test Conditions: Temp: 20 ° C ± 2 ° C , V C : 5.0 V ± 1%, Humidity: 65% ± 5%, V H : 0.9 V ± 1% (in clean air), R L : 50K Ω ±5%, Pre-heating time: more than 48 hours			

D. Mechanical characteristics

Items	Conditions	Specifications
Vibration	Frequency: 100 cpm Vertical amplitude: 4 mm Duration: 1 hour	Should satisfy the specifications shown in the sensitivity characteristics.
Shock	Acceleration: 100G Number of impacts: 5 times	