



## Product Change Notification / SYST-09AZHA626

---

### Date:

10-May-2022

### Product Category:

Power MOSFET Drivers

### PCN Type:

Document Change

### Notification Subject:

Data Sheet - MIC4467/4468/4469 Data Sheet Document Revision

### Affected CPNs:

[SYST-09AZHA626\\_Affected\\_CPN\\_05102022.pdf](#)

[SYST-09AZHA626\\_Affected\\_CPN\\_05102022.csv](#)

### Notification Text:

SYST-09AZHA626

Microchip has released a new Product Documents for the MIC4467/4468/4469 Data Sheet of devices. If you are using one of these devices please read the document located at [MIC4467/4468/4469 Data Sheet](#).

**Notification Status:** Final

#### Description of Change:

- 1) Converted Micrel document MIC4467/8/9 to Microchip data sheet DS20006614A.
- 2) Minor text changes throughout.

**Impacts to Data Sheet:** See above details.

**Reason for Change:** To Improve Productivity

**Change Implementation Status:** Complete

**Date Document Changes Effective:** 10 May 2022

**NOTE:** Please be advised that this is a change to the document only the product has not been changed.

**Markings to Distinguish Revised from Unrevised Devices:** N/A

## Attachments:

[MIC4467/4468/4469 Data Sheet](#)

Please contact your local [Microchip sales office](#) with questions or concerns regarding this notification.

## Terms and Conditions:

If you wish to receive Microchip PCNs via email please register for our PCN email service at our [PCN home page](#) select register then fill in the required fields. You will find instructions about registering for Microchips PCN email service in the [PCN FAQ](#) section.

If you wish to change your PCN profile, including opt out, please go to the [PCN home page](#) select login and sign into your myMicrochip account. Select a profile option from the left navigation bar and make the applicable selections.

Affected Catalog Part Numbers (CPN)

MIC4467YWM

MIC4467YWM-TR

MIC4467ZN

MIC4467ZWM

MIC4467ZWM-TR

MIC4468YN

MIC4468YWM

MIC4468YWM-TR

MIC4468ZN

MIC4468ZWM

MIC4468ZWM-TR

MIC4469YN

MIC4469YWM

MIC4469YWM-TR

MIC4469ZN

MIC4469ZWM

MIC4469ZWM-TR

---

---

## Quad 1.2A Peak Low-Side MOSFET Drivers

---

---

### Features

- Reliable, Low-Power Bipolar/CMOS/DMOS Construction
- Latch-Up Protected to >500 mA Reverse Current
- Logic Input withstands Swing to -5V
- High 3A Peak Output Current
- Wide 4.5V to 18V Operating Range
- Symmetrical Rise and Fall Times
- Short <40 ns Typical Delay Time
- TTL Logic Input Independent of Supply Voltage
- Low Equivalent 6 pF Input Capacitance
- Low 5Ω Typical Output Impedance
- Output Voltage Swings within 25 mV of Ground or  $V_S$ .

### Applications

- General-Purpose CMOS Logic Buffer
- Driving All 4 MOSFETs in an H-Bridge
- Direct Small Motor Driver
- Relay or Peripheral Drivers
- Dual Differential Output Power Drivers
- CCD Driver
- Pin Switching Network Driver

### General Description

The MIC4467/8/9 family of four output CMOS buffer/drivers is an expansion from the earlier single- and dual-output drivers, to which they are functionally closely related. Because package pin count permitted it, each driver has been equipped with a dual input logic gate for added flexibility. Placing four high-power drivers in a single package also improves system reliability and reduces total system cost. In some applications, one of these drivers can replace not only two packages of single-input drivers, but some of the associated logic as well.

Although primarily intended for driving power MOSFETs, and similar highly capacitive loads, these drivers are equally well suited to driving any other load (capacitive, resistive, or inductive), which requires high efficiency, low-impedance driver capable of high peak currents, rail-to-rail voltage swings, and fast switching times. For example, heavily loaded clock lines, coaxial cables, and piezoelectric transducers can all be driven easily with MIC446x series drivers. The only limitation on loading is that total power dissipation in the IC must be kept within the power dissipation limits of the package.

The MIC446x series drivers are built using a BCD process. They will not latch under any conditions within their power and voltage ratings. They are not subject to damage when up to 5V of noise spiking (either polarity) occurs on the ground line. They can accept up to half an amp of inductive kickback current (either polarity) into their outputs without damage or logic upset.

# MIC4467/8/9

## Logic Diagrams

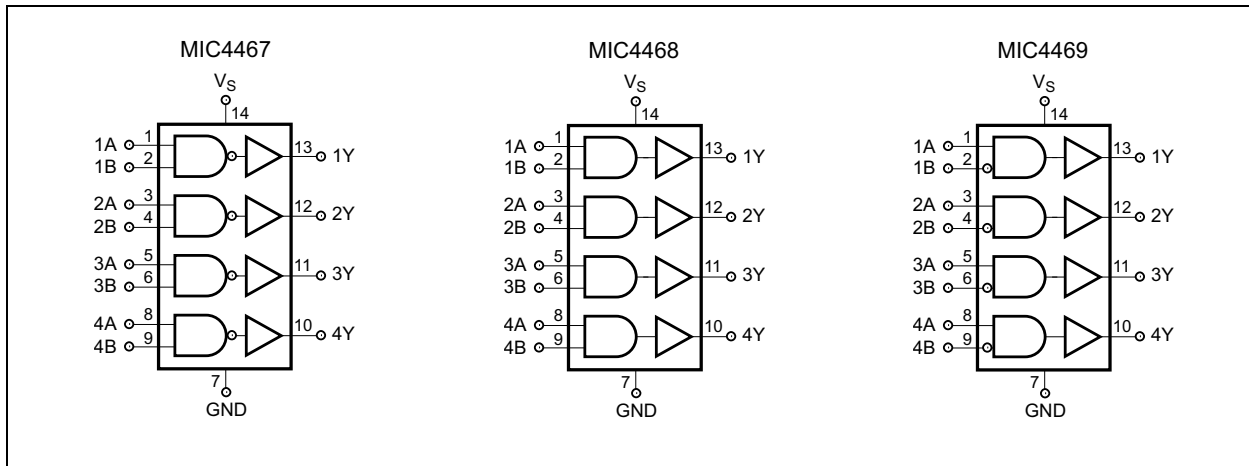

## Block Diagrams

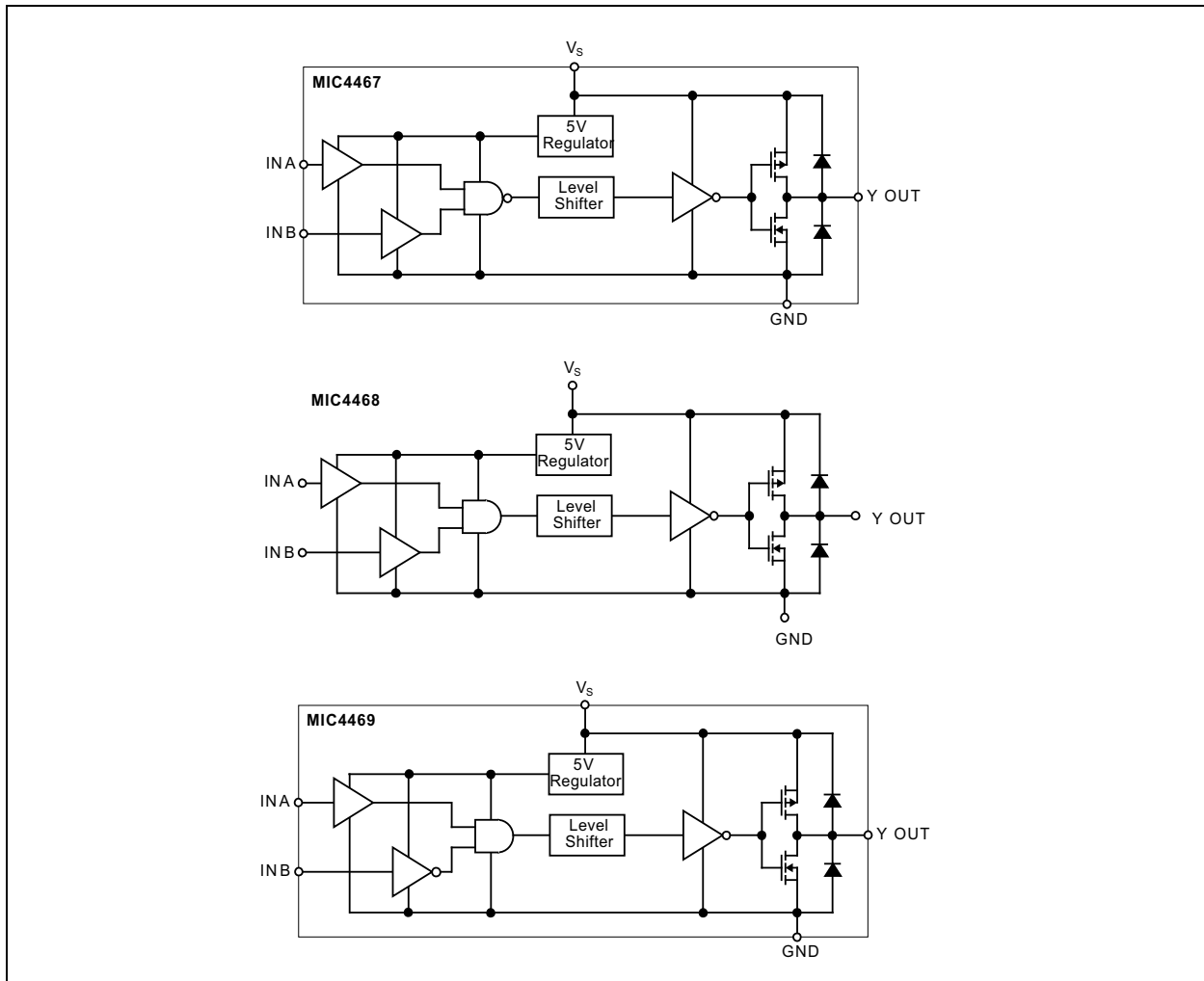

## 1.0 ELECTRICAL CHARACTERISTICS

### Absolute Maximum Ratings †

Supply Voltage .....	+22V
Input Voltage .....	$V_S + 0.3V$ to $GND - 5V$

### Operating Ratings ‡

Power Dissipation	
N Package (14-Pin Plastic DIP) .....	1.5W
WM package (16-Pin Wide SOIC) .....	1W

† **Notice:** Stresses above those listed under “Absolute Maximum Ratings” may cause permanent damage to the device. This is a stress rating only and functional operation of the device at those or any other conditions above those indicated in the operational sections of this specification is not intended. Exposure to maximum rating conditions for extended periods may affect device reliability. Specifications are for packaged product only.

‡ **Notice:** The device is not guaranteed to function outside its operating ratings.

**Note 1:** Devices are ESD sensitive. Handling precautions are recommended. Human body model, 1.5 kΩ in series with 100 pF.

## ELECTRICAL CHARACTERISTICS

**Electrical Characteristics:** Measured at  $T_A = +25^\circ\text{C}$  with  $4.5V \leq V_S \leq 18V$  unless otherwise specified. (Note 1)

Parameter	Symbol	Min.	Typ.	Max.	Units	Conditions
<b>Input</b>						
Logic 1 Input Voltage	$V_{IH}$	2.4	1.3	—	V	—
Logic 0 Input Voltage	$V_{IL}$	—	1.2	0.8	V	—
Input Current	$I_{IN}$	-1	—	1	μA	$0V \leq V_{IN} \leq V_S$
<b>Output</b>						
High Output Voltage	$V_{OH}$	$V_S - 0.15$	—	—	V	$I_{LOAD} = 10\text{ mA}$
Low Output Voltage	$V_{OL}$	—	—	0.15	V	$I_{LOAD} = 10\text{ mA}$
Output Resistance	$R_O$	—	5	15	Ω	$I_{OUT} = 10\text{ mA}, V_S = 18V$
Peak Output Current	$I_{PK}$	—	1.2	—	A	—
Latch-Up Protection Withstand Reverse Current	I	>500	—	—	mA	—
<b>Switching Time</b>						
Rise Time	$t_R$	—	14	25	ns	Figure 1-1
Fall time	$t_F$	—	13	25	ns	Figure 1-1
Delay Time	$t_{D1}$	—	30	75	ns	Figure 1-1
	$t_{D2}$	—	45	75	ns	Figure 1-1
<b>Power Supply</b>						
Power Supply Current	$I_S$	—	0.2	4	mA	—

**Note 1:** Specification for packaged product only.

# MIC4467/8/9

## ELECTRICAL CHARACTERISTICS

**Electrical Characteristics:** Measured over operating temperature range with  $4.5V \leq V_S \leq 18V$  unless otherwise specified. (Note 1)

Parameter	Symbol	Min.	Typ.	Max.	Units	Conditions
<b>Input</b>						
Logic 1 Input Voltage	$V_{IH}$	2.4	1.4	—	V	—
Logic 0 Input Voltage	$V_{IL}$	—	1.0	0.8	V	—
Input Current	$I_{IN}$	-1	—	1	$\mu A$	$0V \leq V_{IN} \leq V_S$
<b>Output</b>						
High Output Voltage	$V_{OH}$	$V_S - 0.3$	—	—	V	$I_{LOAD} = 10 \text{ mA}$
Low Output Voltage	$V_{OL}$	—	—	0.3	V	$I_{LOAD} = 10 \text{ mA}$
Output Resistance	$R_O$	—	7	30	$\Omega$	$I_{OUT} = 10 \text{ mA}, V_S = 18V$
Peak Output Current	$I_{PK}$	—	1.2	—	A	—
Latch-Up Protection Withstand Reverse Current	I	500	—	—	mA	—
<b>Switching Time</b>						
Rise Time	$t_R$	—	17	50	ns	Figure 1-1
Fall time	$t_F$	—	16	50	ns	Figure 1-1
Delay Time	$t_{D1}$	—	35	100	ns	Figure 1-1
	$t_{D2}$	—	55	100	ns	Figure 1-1
<b>Power Supply</b>						
Power Supply Current	$I_S$	—	0.4	8	mA	—

**Note 1:** Specification for packaged product only.

## TEMPERATURE SPECIFICATIONS (Note 1)

Parameters	Symbol	Min.	Typ.	Max.	Units	Conditions
<b>Temperature Ranges</b>						
Operating Ambient Temperature	$T_A$	-40	—	+85	$^{\circ}C$	Temperature Range Device: Y
		0	—	+70	$^{\circ}C$	Temperature Range Device: Z
Maximum Junction Temperature	$T_J$	—	—	+150	$^{\circ}C$	—
Storage Temperature Range	$T_S$	-65	—	+150	$^{\circ}C$	—
Lead Temperature	$T_{LEAD}$	—	—	+300	$^{\circ}C$	Soldering, 10 sec.
<b>Package Thermal Resistances</b>						
Thermal Resistance 14-Lead PDIP	$\theta_{JA}$	—	80	—	$^{\circ}C/W$	—
Thermal Resistance 16-Lead Wide SOIC	$\theta_{JA}$	—	120	—		—

**Note 1:** The maximum allowable power dissipation is a function of ambient temperature, the maximum allowable junction temperature and the thermal resistance from junction to air (i.e.,  $T_A$ ,  $T_J$ ,  $\theta_{JA}$ ).

## Test Circuits

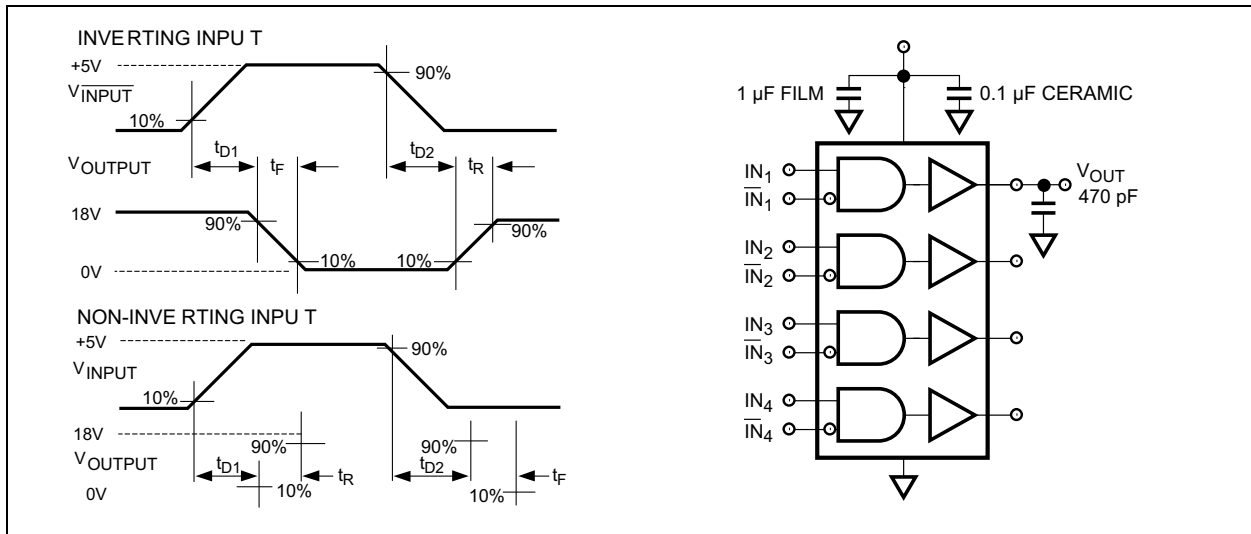

**FIGURE 1-1:** Inverting and Non-Inverting Input.

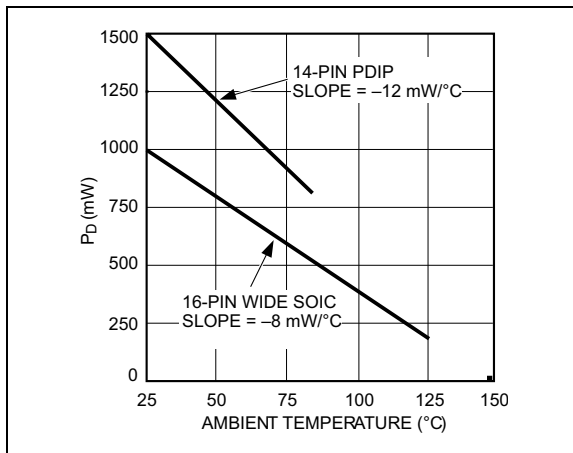

**FIGURE 1-2:** Package Power Dissipation.

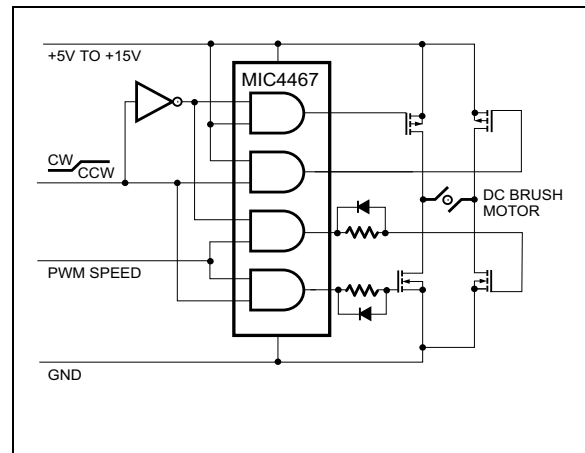

**FIGURE 1-3:** Quad Driver Drives H Bridge to Control motor Speed and Direction.



# MIC4467/8/9

## 2.0 TYPICAL PERFORMANCE CURVES

**Note:** The graphs and tables provided following this note are a statistical summary based on a limited number of samples and are provided for informational purposes only. The performance characteristics listed herein are not tested or guaranteed. In some graphs or tables, the data presented may be outside the specified operating range (e.g., outside specified power supply range) and therefore outside the warranted range.

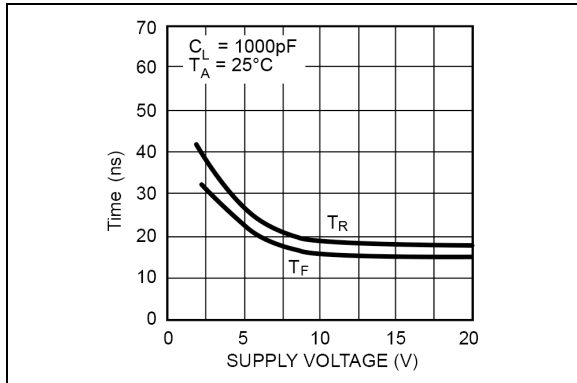

**FIGURE 2-1:** Rise and Fall Time vs. Supply Voltage.

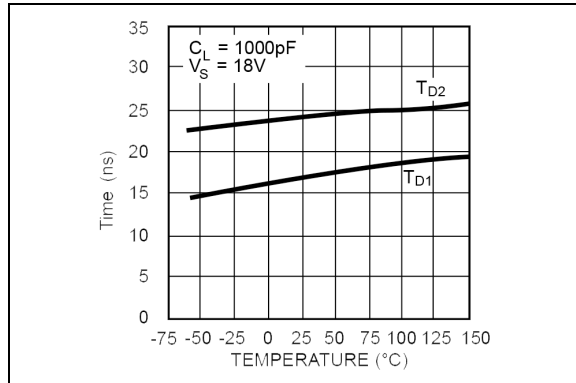

**FIGURE 2-4:** Delay Time vs. Temperature.

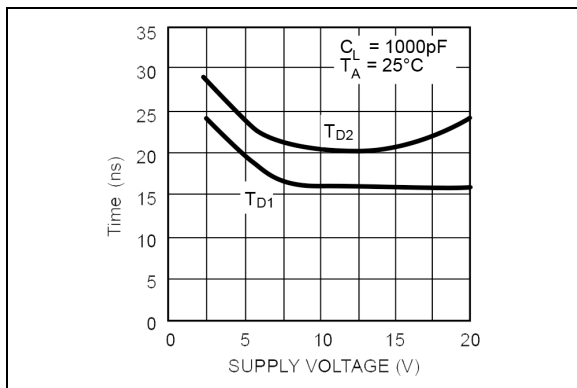

**FIGURE 2-2:** Delay Time vs. Supply Voltage.

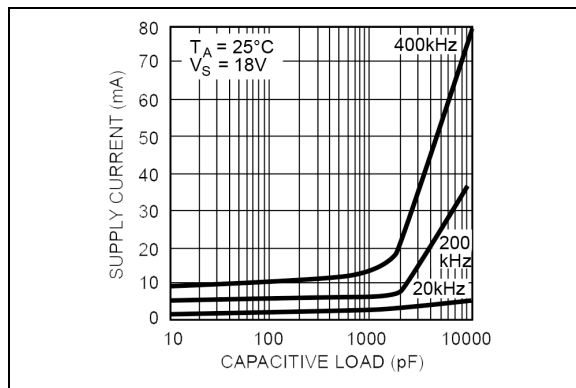

**FIGURE 2-5:** Supply Current vs. Capacitive Load.

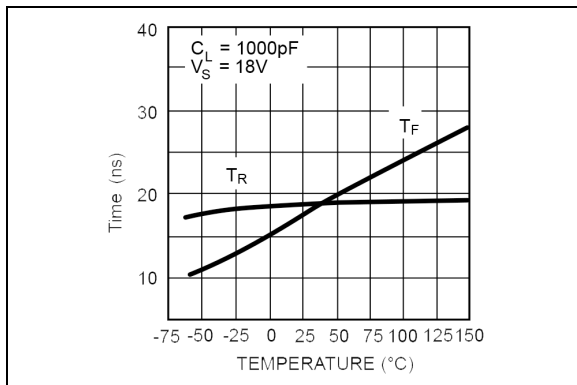

**FIGURE 2-3:** Rise and Fall Time vs. Temperature.

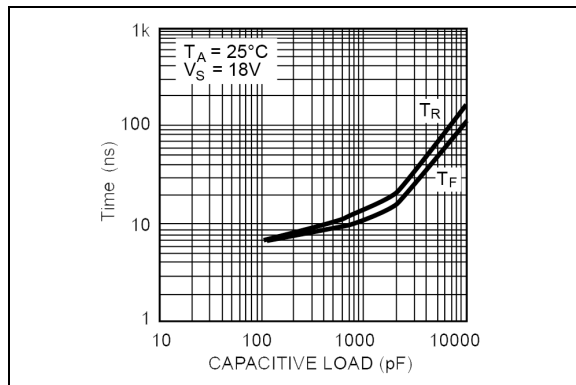

**FIGURE 2-6:** Rise and Fall Time vs. Capacitive Load.

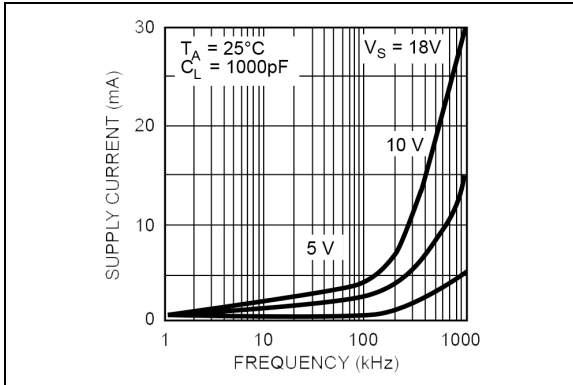

**FIGURE 2-7:** Supply Current vs. Frequency.

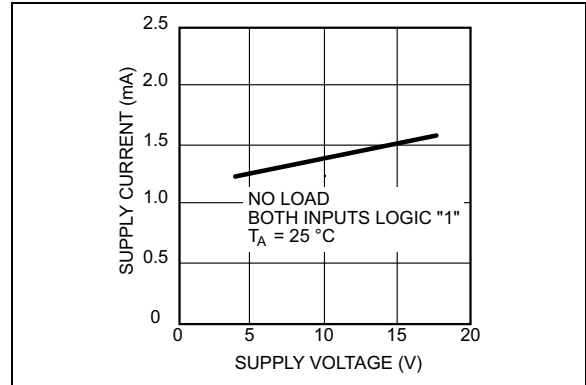

**FIGURE 2-10:** Quiescent Power Supply Current vs. Supply Voltage.

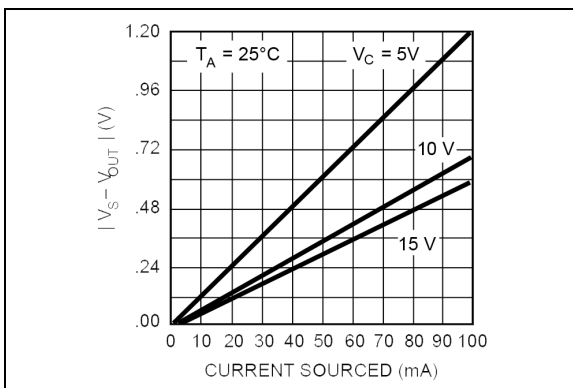

**FIGURE 2-8:** High Output vs. Current.

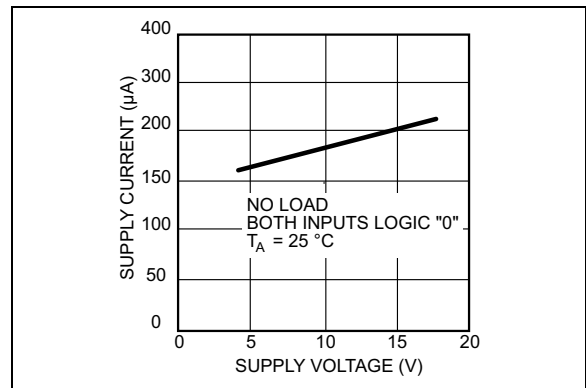

**FIGURE 2-11:** Quiescent Power Supply Current vs. Supply Voltage.

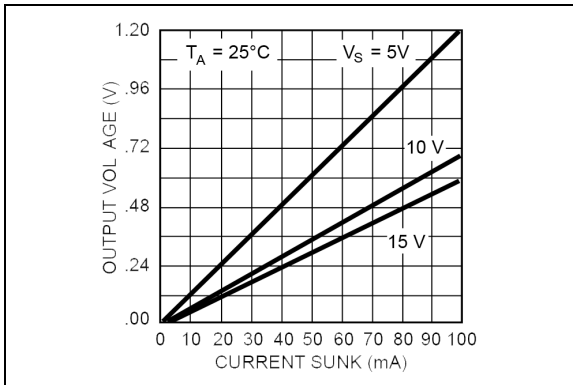
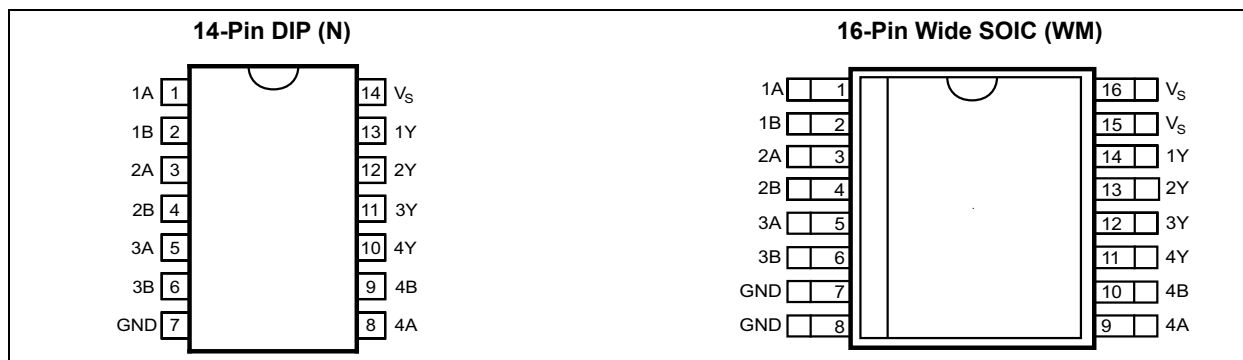

**FIGURE 2-9:** Low Output vs. Current.

# MIC4467/8/9

## 3.0 PIN DESCRIPTIONS

### Package Types



The descriptions of the pins are listed in [Table 3-1](#).

**TABLE 3-1: PIN FUNCTION TABLE**

Pin Number DIP	Pin Number Wide SOIC	Pin Name	Description
1	1	1A	Input A for Driver 1. TTL/CMOS Compatible Input
2	2	1B	Input B for Driver 1. TTL/CMOS Compatible Input
3	3	2A	Input A for Driver 2. TTL/CMOS Compatible Input
4	4	2B	Input B for Driver 2. TTL/CMOS Compatible Input
5	5	3A	Input A for Driver 3. TTL/CMOS Compatible Input
6	6	3B	Input B for Driver 3. TTL/CMOS Compatible Input
7	7	GND	Ground
8	—	4A	Input A for Driver 4. TTL/CMOS Compatible Input
—	8	GND	Ground
9	—	4B	Input B for Driver 4. TTL/CMOS Compatible Input
—	9	4A	Input A for Driver 4. TTL/CMOS Compatible Input
10	—	4Y	Output for Driver 4, CMOS Push-Pull Output
—	10	4B	Input B for Driver 4. TTL/CMOS Compatible Input
11	—	3Y	Output for Driver 3, CMOS Push-Pull Output
—	11	4Y	Output for Driver 4, CMOS Push-Pull Output
12	—	2Y	Output for Driver 2, CMOS Push-Pull Output
—	12	3Y	Output for Driver 3, CMOS Push-Pull Output
13	—	1Y	Output for Driver 1, CMOS Push-Pull Output
—	13	2Y	Output for Driver 2, CMOS Push-Pull Output
14	—	VS	Supply Input, 4.5V to 18V
—	14	1Y	Output for Driver 1, CMOS Push-Pull Output
—	15	VS	Supply Input, 4.5V to 18V
—	16	VS	Supply Input, 4.5V to 18V

## 3.1 Truth Table

TABLE 3-2: TRUTH TABLE

Part No.	Inputs		Output
	A	B	Y
MIC4467 (Each Driver)	L	X	H
	X	L	H
	H	H	L
MIC4468 (Each Driver)	H	H	H
	L	X	L
	X	L	L
MIC4469 (Each Driver)	L	X	L
	X	H	L
	H	L	H

# MIC4467/8/9

## 4.0 PACKAGING INFORMATION

### 4.1 Package Marking Information

16-Lead PDIP\*

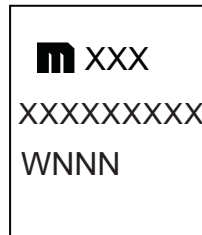

Example

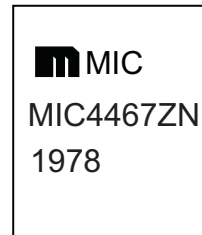

16-Lead Wide SOIC\*



Example



<p><b>Legend:</b> XX...X Product code or customer-specific information Y Year code (last digit of calendar year) YY Year code (last 2 digits of calendar year) WW Week code (week of January 1 is week '01') NNN Alphanumeric traceability code Ⓔ Pb-free JEDEC® designator for Matte Tin (Sn) * This package is Pb-free. The Pb-free JEDEC designator (Ⓔ) can be found on the outer packaging for this package.</p> <p>●, ▲, ▼ Pin one index is identified by a dot, delta up, or delta down (triangle mark).</p>
<p><b>Note:</b> In the event the full Microchip part number cannot be marked on one line, it will be carried over to the next line, thus limiting the number of available characters for customer-specific information. Package may or may not include the corporate logo.</p> <p>Underbar ( ) and/or Overbar ( ) symbol may not be to scale.</p>

**Note:** If the full seven-character YYWWNNN code cannot fit on the package, the following truncated codes are used based on the available marking space:  
6 Characters = YWWNNN; 5 Characters = WWNNN; 4 Characters = WNNN; 3 Characters = NNN;  
2 Characters = NN; 1 Character = N

## 14-Lead Plastic DIP Package Outline and Recommended Land Pattern

**TITLE**

14 LEAD PDIP PACKAGE OUTLINE & RECOMMENDED LAND PATTERN

<b>DRAWING #</b>	PDIP-14LD-PL-1	<b>UNIT</b>	INCH
<b>LEAD FRAME</b>	Copper	<b>LEAD FINISH</b>	Matte Tin

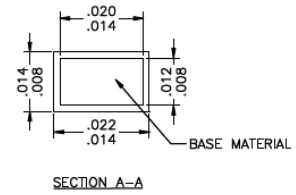
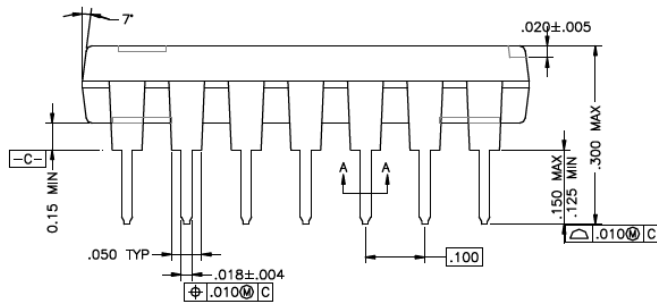
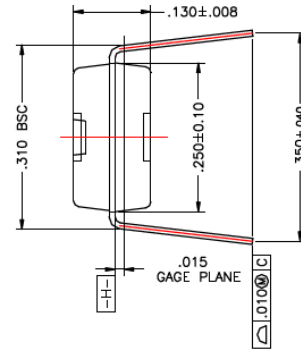
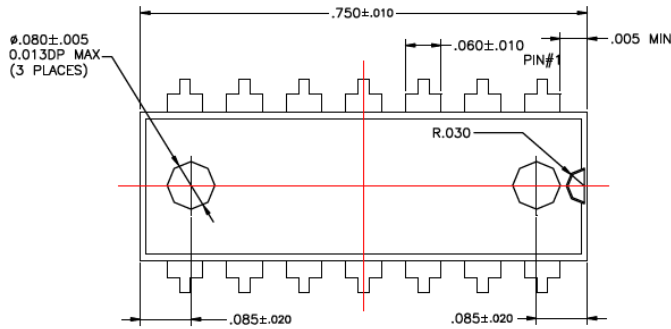

Note: For the most current package drawings, please see the Microchip Packaging Specification located at <http://www.microchip.com/packaging>.

# MIC4467/8/9

## 16-Lead Wide SOIC Package Outline and Recommended Land Pattern

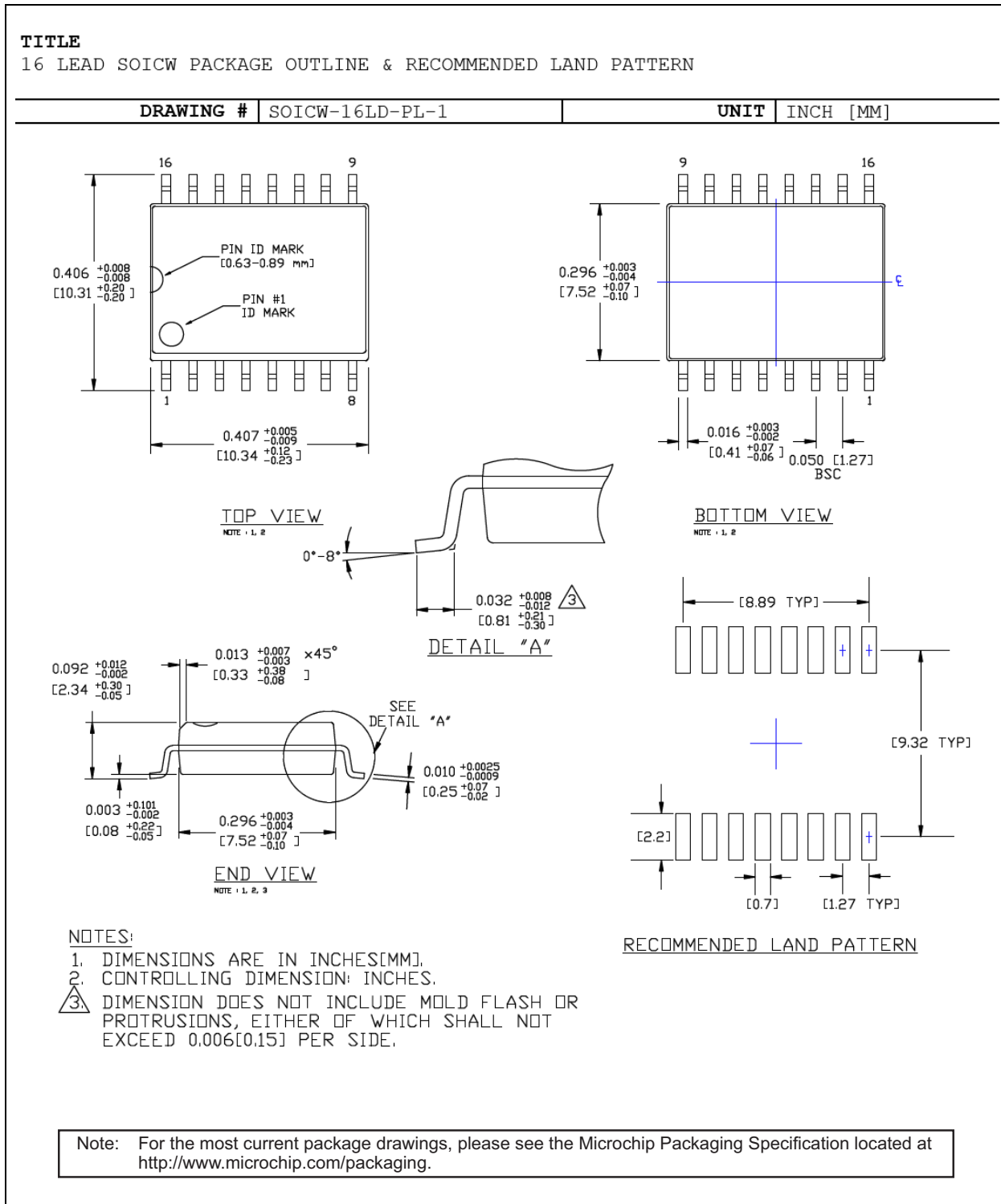

## APPENDIX A: REVISION HISTORY

### Revision A (May 2022)

- Converted Micrel document MIC4467/8/9 to Microchip data sheet DS20006614A.
- Minor text changes throughout.



# MIC4467/8/9

---

---

NOTES:

## PRODUCT IDENTIFICATION SYSTEM

To order or obtain information, e.g., on pricing or delivery, contact your local Microchip representative or sales office.

<u>PART NO.</u>	<u>X</u>	<u>XX</u>	<u>-XX</u>	<b>Examples:</b>
Device	Temperature Range	Package	Media Type	
<b>Device:</b>	MIC4467: Quad 1.2A-Peak Low-Side MOSFET Driver with Bi-Polar/CMOS/DMOS Process featuring NAND Input Logic			<b>a) MIC4467:</b> 1.2A-Peak, Quad Low-Side MOSFET Driver, NAND Input Logic, -40°C to +85°C Industrial Temperature Range, RoHS Compliant MIC4467YWM 16-Lead SOIC Wide Package, 47/Tube MIC4467YWM-TR 16-Lead SOIC Wide Package, 1,000/Reel
	MIC4468: Quad 1.2A-Peak Low-Side MOSFET Driver with Bi-Polar/CMOS/DMOS Process featuring AND Input Logic			<b>b) MIC4467:</b> 1.2A-Peak, Quad Low-Side MOSFET Driver, NAND Input Logic, 0°C to +70°C Commercial Temperature Range, RoHS Compliant MIC4467ZN 14-Lead PDIP Package, 25/Tube MIC4467ZWM 16-Lead SOIC Wide Package, 47/Tube MIC4467ZWM-TR 16-Lead SOIC Wide Package, 1000/Reel
	MIC4469: Quad 1.2A-Peak Low-Side MOSFET Driver with Bi-Polar/CMOS/DMOS Process featuring AND with 1 Inverting Input Logic			<b>c) MIC4468:</b> 1.2A-Peak, Quad Low-Side MOSFET Driver, AND Input Logic, -40°C to +85°C Industrial Temperature Range, RoHS Compliant MIC4468YN 14-Lead PDIP Package, 25/Tube MIC4468YWM 16-Lead SOIC Wide Package, 47/Tube MIC4468YWM-TR 16-Lead SOIC Wide Package, 1,000/Reel
<b>Temperature Range:</b>	Y = -40°C to +85°C, Industrial (RoHS Compliant)			<b>d) MIC4468:</b> 1.2A-Peak, Quad Low-Side MOSFET Driver, AND Input Logic, 0°C to +70°C Commercial Temperature Range, RoHS Compliant MIC4468ZN 14-Lead PDIP Package, 25/Tube MIC4468ZWM 16-Lead SOIC Wide Package, 47/Tube MIC4468ZWM-TR 16-Lead SOIC Wide Package, 1,000/Reel
	Z = 0°C to +70°C, Commercial (RoHS Compliant)			<b>MIC4469:</b> 1.2A-Peak, Quad Low-Side MOSFET Driver, AND with 1 Inverting Input Logic, -40°C to +85°C Industrial Temperature Range, RoHS Compliant MIC4469YN 14-Lead PDIP Package, 25/Tube MIC4469YWM 16-Lead SOIC Wide Package, 47/Tube MIC4469YWM-TR 16-Lead SOIC Wide Package, 1,000/Reel
<b>Package:</b>	N = 14-Lead PDIP			<b>MIC4469:</b> 1.2A-Peak, Quad Low-Side MOSFET Driver, AND with 1 Inverting Input Logic, -40°C to +85°C Commercial Temperature Range, RoHS Compliant MIC4469ZN 14-Lead PDIP Package, 25/Tube MIC4469ZWM 16-Lead SOIC Wide Package, 47/Tube MIC4469WM-TR 16-Lead SOIC Wide Package, 1,000/Reel
	WM = 16-Lead SOIC (Wide Body)			
<b>Media Type:</b>	<blank> = 25/Tube (N, PDIP)			
	<blank> = 47/Tube (WM, SOIC)			
	TR = 1,000/Reel (WM, SOIC)			
				<b>Note 1:</b> Tape and Reel identifier only appears in the catalog part number description. This identifier is used for ordering purposes and is not printed on the device package. Check with your Microchip Sales Office for package availability with the Tape and Reel option.

# MIC4467/8/9

---

---

NOTES:

---

---

**Note the following details of the code protection feature on Microchip products:**

- Microchip products meet the specifications contained in their particular Microchip Data Sheet.
- Microchip believes that its family of products is secure when used in the intended manner, within operating specifications, and under normal conditions.
- Microchip values and aggressively protects its intellectual property rights. Attempts to breach the code protection features of Microchip product is strictly prohibited and may violate the Digital Millennium Copyright Act.
- Neither Microchip nor any other semiconductor manufacturer can guarantee the security of its code. Code protection does not mean that we are guaranteeing the product is “unbreakable”. Code protection is constantly evolving. Microchip is committed to continuously improving the code protection features of our products.

---

This publication and the information herein may be used only with Microchip products, including to design, test, and integrate Microchip products with your application. Use of this information in any other manner violates these terms. Information regarding device applications is provided only for your convenience and may be superseded by updates. It is your responsibility to ensure that your application meets with your specifications. Contact your local Microchip sales office for additional support or, obtain additional support at <https://www.microchip.com/en-us/support/design-help/client-support-services>.

THIS INFORMATION IS PROVIDED BY MICROCHIP "AS IS". MICROCHIP MAKES NO REPRESENTATIONS OR WARRANTIES OF ANY KIND WHETHER EXPRESS OR IMPLIED, WRITTEN OR ORAL, STATUTORY OR OTHERWISE, RELATED TO THE INFORMATION INCLUDING BUT NOT LIMITED TO ANY IMPLIED WARRANTIES OF NON-INFRINGEMENT, MERCHANTABILITY, AND FITNESS FOR A PARTICULAR PURPOSE, OR WARRANTIES RELATED TO ITS CONDITION, QUALITY, OR PERFORMANCE.

IN NO EVENT WILL MICROCHIP BE LIABLE FOR ANY INDIRECT, SPECIAL, PUNITIVE, INCIDENTAL, OR CONSEQUENTIAL LOSS, DAMAGE, COST, OR EXPENSE OF ANY KIND WHATSOEVER RELATED TO THE INFORMATION OR ITS USE, HOWEVER CAUSED, EVEN IF MICROCHIP HAS BEEN ADVISED OF THE POSSIBILITY OR THE DAMAGES ARE FORESEEABLE. TO THE FULLEST EXTENT ALLOWED BY LAW, MICROCHIP'S TOTAL LIABILITY ON ALL CLAIMS IN ANY WAY RELATED TO THE INFORMATION OR ITS USE WILL NOT EXCEED THE AMOUNT OF FEES, IF ANY, THAT YOU HAVE PAID DIRECTLY TO MICROCHIP FOR THE INFORMATION.

Use of Microchip devices in life support and/or safety applications is entirely at the buyer's risk, and the buyer agrees to defend, indemnify and hold harmless Microchip from any and all damages, claims, suits, or expenses resulting from such use. No licenses are conveyed, implicitly or otherwise, under any Microchip intellectual property rights unless otherwise stated.

For information regarding Microchip's Quality Management Systems, please visit [www.microchip.com/quality](http://www.microchip.com/quality).

**Trademarks**

The Microchip name and logo, the Microchip logo, Adaptec, AnyRate, AVR, AVR logo, AVR Freaks, BesTime, BitCloud, CryptoMemory, CryptoRF, dsPIC, flexPWR, HELDO, IGLOO, JukeBlox, KeeLoq, Kleer, LANCheck, LinkMD, maXStylus, maXTouch, MediaLB, megaAVR, Microsemi, Microsemi logo, MOST, MOST logo, MPLAB, OptoLyzer, PIC, picoPower, PICSTART, PIC32 logo, PolarFire, Prochip Designer, QTouch, SAM-BA, SenGenuity, SpyNIC, SST, SST Logo, SuperFlash, Symmetricom, SyncServer, Tachyon, TimeSource, tinyAVR, UNI/O, Vectron, and XMEGA are registered trademarks of Microchip Technology Incorporated in the U.S.A. and other countries.

AgileSwitch, APT, ClockWorks, The Embedded Control Solutions Company, EtherSynch, Flashtec, Hyper Speed Control, HyperLight Load, IntelliMOS, Libero, motorBench, mTouch, Powermite 3, Precision Edge, ProASIC, ProASIC Plus, ProASIC Plus logo, QuietWire, SmartFusion, SyncWorld, Temux, TimeCesium, TimeHub, TimePictra, TimeProvider, TrueTime, WinPath, and ZL are registered trademarks of Microchip Technology Incorporated in the U.S.A.

Adjacent Key Suppression, AKS, Analog-for-the-Digital Age, Any Capacitor, AnyIn, AnyOut, Augmented Switching, BlueSky, BodyCom, CodeGuard, CryptoAuthentication, CryptoAutomotive, CryptoCompanion, CryptoController, dsPICDEM, dsPICDEM.net, Dynamic Average Matching, DAM, ECAN, Espresso T1S, EtherGREEN, GridTime, IdealBridge, In-Circuit Serial Programming, ICSP, INICnet, Intelligent Paralleling, Inter-Chip Connectivity, JitterBlocker, Knob-on-Display, maxCrypto, maxView, memBrain, Mindi, MiWi, MPASM, MPF, MPLAB Certified logo, MPLIB, MPLINK, MultiTRAK, NetDetach, NVM Express, NVMe, Omniscient Code Generation, PICDEM, PICDEM.net, PICkit, PICtail, PowerSmart, PureSilicon, QMatrix, REAL ICE, Ripple Blocker, RTAX, RTG4, SAM-ICE, Serial Quad I/O, simpleMAP, SimpliPHY, SmartBuffer, SmartHLS, SMART-I.S., storClad, SQI, SuperSwitcher, SuperSwitcher II, Switchtec, SynchroPHY, Total Endurance, TSHARC, USBCheck, VariSense, VectorBlox, VeriPHY, ViewSpan, WiperLock, XpressConnect, and ZENA are trademarks of Microchip Technology Incorporated in the U.S.A. and other countries.

SQTP is a service mark of Microchip Technology Incorporated in the U.S.A.

The Adaptec logo, Frequency on Demand, Silicon Storage Technology, Symmcom, and Trusted Time are registered trademarks of Microchip Technology Inc. in other countries.

GestIC is a registered trademark of Microchip Technology Germany II GmbH & Co. KG, a subsidiary of Microchip Technology Inc., in other countries.

All other trademarks mentioned herein are property of their respective companies.

© 2022, Microchip Technology Incorporated and its subsidiaries.

All Rights Reserved.

ISBN: 978-1-6683-0406-8



# MICROCHIP

## Worldwide Sales and Service

### AMERICAS

**Corporate Office**  
2355 West Chandler Blvd.  
Chandler, AZ 85224-6199  
Tel: 480-792-7200  
Fax: 480-792-7277  
Technical Support:  
<http://www.microchip.com/support>  
Web Address:  
[www.microchip.com](http://www.microchip.com)

#### Atlanta

Duluth, GA  
Tel: 678-957-9614  
Fax: 678-957-1455

#### Austin, TX

Tel: 512-257-3370

#### Boston

Westborough, MA  
Tel: 774-760-0087  
Fax: 774-760-0088

#### Chicago

Itasca, IL  
Tel: 630-285-0071  
Fax: 630-285-0075

#### Dallas

Addison, TX  
Tel: 972-818-7423  
Fax: 972-818-2924

#### Detroit

Novi, MI  
Tel: 248-848-4000

#### Houston, TX

Tel: 281-894-5983

#### Indianapolis

Noblesville, IN  
Tel: 317-773-8323  
Fax: 317-773-5453  
Tel: 317-536-2380

#### Los Angeles

Mission Viejo, CA  
Tel: 949-462-9523  
Fax: 949-462-9608  
Tel: 951-273-7800

#### Raleigh, NC

Tel: 919-844-7510

#### New York, NY

Tel: 631-435-6000

#### San Jose, CA

Tel: 408-735-9110  
Tel: 408-436-4270

#### Canada - Toronto

Tel: 905-695-1980  
Fax: 905-695-2078

### ASIA/PACIFIC

**Australia - Sydney**  
Tel: 61-2-9868-6733

**China - Beijing**  
Tel: 86-10-8569-7000

**China - Chengdu**  
Tel: 86-28-8665-5511

**China - Chongqing**  
Tel: 86-23-8980-9588

**China - Dongguan**  
Tel: 86-769-8702-9880

**China - Guangzhou**  
Tel: 86-20-8755-8029

**China - Hangzhou**  
Tel: 86-571-8792-8115

**China - Hong Kong SAR**  
Tel: 852-2943-5100

**China - Nanjing**  
Tel: 86-25-8473-2460

**China - Qingdao**  
Tel: 86-532-8502-7355

**China - Shanghai**  
Tel: 86-21-3326-8000

**China - Shenyang**  
Tel: 86-24-2334-2829

**China - Shenzhen**  
Tel: 86-755-8864-2200

**China - Suzhou**  
Tel: 86-186-6233-1526

**China - Wuhan**  
Tel: 86-27-5980-5300

**China - Xian**  
Tel: 86-29-8833-7252

**China - Xiamen**  
Tel: 86-592-2388138

**China - Zhuhai**  
Tel: 86-756-3210040

### ASIA/PACIFIC

**India - Bangalore**  
Tel: 91-80-3090-4444

**India - New Delhi**  
Tel: 91-11-4160-8631

**India - Pune**  
Tel: 91-20-4121-0141

**Japan - Osaka**  
Tel: 81-6-6152-7160

**Japan - Tokyo**  
Tel: 81-3-6880-3770

**Korea - Daegu**  
Tel: 82-53-744-4301

**Korea - Seoul**  
Tel: 82-2-554-7200

**Malaysia - Kuala Lumpur**  
Tel: 60-3-7651-7906

**Malaysia - Penang**  
Tel: 60-4-227-8870

**Philippines - Manila**  
Tel: 63-2-634-9065

**Singapore**  
Tel: 65-6334-8870

**Taiwan - Hsin Chu**  
Tel: 886-3-577-8366

**Taiwan - Kaohsiung**  
Tel: 886-7-213-7830

**Taiwan - Taipei**  
Tel: 886-2-2508-8600

**Thailand - Bangkok**  
Tel: 66-2-694-1351

**Vietnam - Ho Chi Minh**  
Tel: 84-28-5448-2100

### EUROPE

**Austria - Wels**  
Tel: 43-7242-2244-39  
Fax: 43-7242-2244-393

**Denmark - Copenhagen**  
Tel: 45-4485-5910  
Fax: 45-4485-2829

**Finland - Espoo**  
Tel: 358-9-4520-820

**France - Paris**  
Tel: 33-1-69-53-63-20  
Fax: 33-1-69-30-90-79

**Germany - Garching**  
Tel: 49-8931-9700

**Germany - Haan**  
Tel: 49-2129-3766400

**Germany - Heilbronn**  
Tel: 49-7131-72400

**Germany - Karlsruhe**  
Tel: 49-721-625370

**Germany - Munich**  
Tel: 49-89-627-144-0  
Fax: 49-89-627-144-44

**Germany - Rosenheim**  
Tel: 49-8031-354-560

**Israel - Ra'anana**  
Tel: 972-9-744-7705

**Italy - Milan**  
Tel: 39-0331-742611  
Fax: 39-0331-466781

**Italy - Padova**  
Tel: 39-049-7625286

**Netherlands - Drunen**  
Tel: 31-416-690399  
Fax: 31-416-690340

**Norway - Trondheim**  
Tel: 47-7288-4388

**Poland - Warsaw**  
Tel: 48-22-3325737

**Romania - Bucharest**  
Tel: 40-21-407-87-50

**Spain - Madrid**  
Tel: 34-91-708-08-90  
Fax: 34-91-708-08-91

**Sweden - Gothenberg**  
Tel: 46-31-704-60-40

**Sweden - Stockholm**  
Tel: 46-8-5090-4654

**UK - Wokingham**  
Tel: 44-118-921-5800  
Fax: 44-118-921-5820