

## Copy and face milling cutter heads

For milling cutter indexable inserts RD..1003., RD..12T3., RD..1604..

**ATORN**<sup>®</sup>

### Application

For face milling and copy milling, light and medium chipping

### Version

- Wear-resistant, nickel-plated version
- With internal cooling
- Clamping screw tightening torque (indexable insert) M3.5 = 3.5 Nm, M4.5 = 7.6 Nm

<b>Art. No.</b>	<b>16035 380</b>
<b>Max. cutting edge diameter</b>	80 mm
<b>Length</b>	50 mm
<b>Bore diameter</b>	27 mm
<b>max. ap</b>	4 mm
<b>Number of cutting edges</b>	6 PCS
<b>Suitable indexable insert no.</b>	34

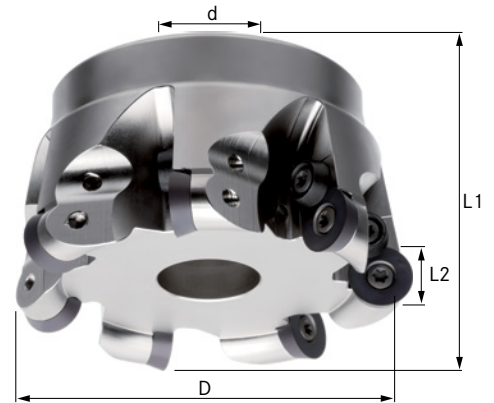

### EAN-Code

4050293320114