

Operating Instructions

RIA45

Process indicator



Table of contents

1	About this document	4	9	Maintenance	41
1.1	Symbols	4	9.1	Cleaning	41
1.2	Documentation	5	10	Repair	42
2	Safety instructions	7	10.1	General notes	42
2.1	Requirements for the personnel	7	10.2	Spare parts	42
2.2	Intended use	7	10.3	Return	43
2.3	Workplace safety	7	10.4	Disposal	43
2.4	Operational safety	7	11	Accessories	44
2.5	Product safety	8	11.1	Device-specific accessories	44
3	Incoming acceptance and product identification	9	11.2	Communication-specific accessories	44
3.1	Incoming acceptance	9	12	Technical data	45
3.2	Product identification	9	12.1	Input	45
3.3	Certificates and approvals	9	12.2	Output	45
3.4	Storage and transport	10	12.3	Power supply	47
4	Mounting	11	12.4	Performance characteristics	48
4.1	Installation requirements	11	12.5	Installation	49
4.2	Dimensions	11	12.6	Environment	50
4.3	Mounting procedure	11	12.7	Mechanical construction	51
4.4	Post-installation check	12	12.8	Operability	52
5	Wiring	13	12.9	Accessories	53
5.1	Electrical connection	13	13	Appendix	54
5.2	Post-connection check	15	13.1	Further explanations regarding the differential pressure application in level measurement	54
6	Operation	16	13.2	Display menu	56
6.1	Operating elements	16	13.3	Setup menu	57
6.2	Display and device status indicator / LED	18	13.4	Diagnostics menu	66
6.3	Symbols	18	13.5	Expert menu	68
6.4	Quick guide to the operating matrix	19	Index	75	
7	Commissioning	23			
7.1	Post-installation check and switching on the device	23			
7.2	General information about configuring the device	23			
7.3	Notes on setup access protection	23			
7.4	Device configuration	24			
7.5	In operation	36			
8	Diagnostics and troubleshooting ...	40			
8.1	General troubleshooting	40			
8.2	Overview of diagnostic information	40			
8.3	Diagnosis list	40			

1 About this document

1.1 Symbols

1.1.1 Safety symbols

DANGER

This symbol alerts you to a dangerous situation. Failure to avoid this situation will result in serious or fatal injury.

WARNING

This symbol alerts you to a dangerous situation. Failure to avoid this situation can result in serious or fatal injury.





CAUTION

This symbol alerts you to a dangerous situation. Failure to avoid this situation can result in minor or medium injury.







NOTICE







This symbol contains information on procedures and other facts which do not result in personal injury.

1.1.2 Electrical symbols





Symbol	Meaning
	Direct current
	Alternating current
	Direct current and alternating current
	Ground connection A grounded terminal which, as far as the operator is concerned, is grounded via a grounding system.
	Potential equalization connection (PE: protective earth) Ground terminals that must be connected to ground prior to establishing any other connections. The ground terminals are located on the interior and exterior of the device: <ul style="list-style-type: none"> ▪ Interior ground terminal: potential equalization is connected to the supply network. ▪ Exterior ground terminal: device is connected to the plant grounding system.

1.1.3 Symbols for certain types of information

Symbol	Meaning
	Permitted Procedures, processes or actions that are permitted.
	Preferred Procedures, processes or actions that are preferred.
	Forbidden Procedures, processes or actions that are forbidden.
	Tip Indicates additional information.
	Reference to documentation
	Reference to page

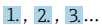
Symbol	Meaning
	Reference to graphic
	Notice or individual step to be observed
	Series of steps
	Result of a step
	Help in the event of a problem
	Visual inspection

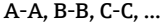
1.1.4 Symbols in graphics

Symbol	Meaning	Symbol	Meaning
	Item numbers		Series of steps
	Views		Sections
	Hazardous area		Safe area (non-hazardous area)

1.2 Documentation

Document	Purpose and content of the document
Technical Information (TI)	Planning aid for your device The document contains all the technical data on the device and provides an overview of the accessories and other products that can be ordered for the device.
Brief Operating Instructions (KA)	Guide that takes you quickly to the 1st measured value The Brief Operating Instructions contain all the essential information from incoming acceptance to initial commissioning.
Operating Instructions (BA)	Your reference document The Operating Instructions contain all the information that is required in various phases of the life cycle of the device: from product identification, incoming acceptance and storage, to mounting, connection, operation and commissioning through to troubleshooting, maintenance and disposal.
Description of Device Parameters (GP)	Reference for your parameters The document provides a detailed explanation of each individual parameter. The description is aimed at those who work with the device over the entire life cycle and perform specific configurations.

Document	Purpose and content of the document
Safety Instructions (XA)	<p>Depending on the approval, Safety Instructions (XA) are supplied with the device. The Safety Instructions are an integral part of the Operating Instructions.</p> <p> Information on the Safety Instructions (XA) that are relevant for the device is provided on the nameplate.</p>
Supplementary device-dependent documentation (SD/FY)	<p>Additional documents are supplied depending on the device version ordered: Always comply strictly with the instructions in the supplementary documentation. The supplementary documentation is an integral part of the device documentation.</p>

-  The document types listed are available:
- In the Download Area of the Endress+Hauser Internet site: www.endress.com → Download
 - Enter the serial number from the nameplate in the W@M Device Viewer (www.endress.com/deviceviewer): all data relating to the device and an overview of the Technical Documentation supplied with the device are displayed.
 - Enter the serial number on the nameplate into the Endress+Hauser Operations app or scan the 2-D matrix code (QR code) on the nameplate with the Endress+Hauser Operations app: all data relating to the device and the Technical Documentation pertaining to the device is displayed.

2 Safety instructions

2.1 Requirements for the personnel

The personnel for installation, commissioning, diagnostics and maintenance must fulfill the following requirements:

- ▶ Trained, qualified specialists must have a relevant qualification for this specific function and task.
- ▶ Are authorized by the plant owner/operator.
- ▶ Are familiar with federal/national regulations.
- ▶ Before starting work, read and understand the instructions in the manual and supplementary documentation as well as the certificates (depending on the application).
- ▶ Follow instructions and comply with basic conditions.

The operating personnel must fulfill the following requirements:

- ▶ Are instructed and authorized according to the requirements of the task by the facility's owner-operator.
- ▶ Follow the instructions in this manual.

2.2 Intended use

The process indicator evaluates analog process variables and displays them on its multicolored screen. Processes can be monitored and controlled with the device's outputs and limit relays. The device is equipped with a wide array of software functions for this purpose. Power can be supplied to 2-wire sensors with the integrated loop power supply.

- The device is an associated apparatus and may not be installed in the hazardous area.
- The manufacturer accepts no liability for damages resulting from incorrect use or use other than that intended. It is not permitted to convert or modify the device in any way.
- The device is designed for installation in a panel and must only be operated in an installed state.

2.3 Workplace safety

When working on and with the device:

- ▶ Wear the required personal protective equipment as per national regulations.

2.4 Operational safety

Risk of injury!

- ▶ Operate the device only if it is in proper technical condition, free from errors and faults.
- ▶ The operator is responsible for the interference-free operation of the device.

Modifications to the device

Unauthorized modifications to the device are not permitted and can lead to unforeseeable dangers!

- ▶ If modifications are nevertheless required, consult with the manufacturer.

Repair

To ensure continued operational safety and reliability:

- ▶ Carry out repairs on the device only if they are expressly permitted.
- ▶ Observe federal/national regulations pertaining to the repair of an electrical device.
- ▶ Use only original spare parts and accessories.

2.5 Product safety

This product is designed in accordance with good engineering practice to meet state-of-the-art safety requirements and has been tested and left the factory in a condition in which it is safe to operate.

3 Incoming acceptance and product identification

3.1 Incoming acceptance

Proceed as follows on receipt of the device:

1. Check whether the packaging is intact.
2. If damage is discovered:
Report all damage immediately to the manufacturer.
3. Do not install damaged material, as the manufacturer cannot otherwise guarantee compliance with the safety requirements and cannot be held responsible for the consequences that may result.
4. Compare the scope of delivery to the contents of the order.
5. Remove all the packaging material used for transportation.

3.2 Product identification

The following options are available for identification of the device:

- Nameplate specifications
- Extended order code with breakdown of the device features on the delivery note
- Enter the serial number from the nameplate in the *W@M Device Viewer* (www.endress.com/deviceviewer): all data relating to the device and an overview of the Technical Documentation supplied with the device are displayed.
- Enter the serial number on the nameplate into the *Endress+Hauser Operations App* or scan the 2-D matrix code (QR code) on the nameplate with the *Endress+Hauser Operations App*: all the information about the device and the technical documentation pertaining to the device is displayed.

3.2.1 Nameplate

The right device?



Check the information on the nameplate of the device:

- Product name and manufacturer ID
- Order code, extended order code and serial number
- Power supply and power consumption
- Approvals
- Temperature range
- Firmware version and device revision

3.2.2 Name and address of manufacturer

Name of manufacturer:	Endress+Hauser Wetzler GmbH + Co. KG
Address of manufacturer:	Obere Wank 1, D-87484 Nesselwang
Model/type reference:	RIA45

3.3 Certificates and approvals

-  For certificates and approvals valid for the device: see the data on the nameplate
-  Approval-related data and documents: www.endress.com/deviceviewer → (enter the serial number)

3.3.1 Other standards and guidelines

- IEC 60529:
Degrees of protection provided by enclosures (IP code)
- IEC 61010-1:
Safety requirements for electrical equipment for measurement, control and laboratory use
- EN 60079-11:
Explosive atmospheres - Part 11: Equipment protection by intrinsic safety "I" (optional)

3.4 Storage and transport

Please note the following:

The permitted storage temperature is -40 to 85 °C (-40 to 185 °F); it is possible to store the device at borderline temperatures for a limited period (48 hours maximum).

 Pack the device for storage and transportation in such a way that it is reliably protected against impact and external influences. The original packaging offers the best protection.

Avoid the following environmental influences during storage and transport:

- Direct sunlight
- Vibration
- Aggressive media

4 Mounting

4.1 Installation requirements

NOTICE

High temperatures reduce the life-time of the display.

- ▶ To avoid heat accumulation, ensure the device is sufficiently cooled.
- ▶ Do not operate the device in the upper temperature range over a longer period of time.

The process indicator is designed for use in a panel.

The orientation is determined by the legibility of the display. The connections and outputs are provided on the rear. The cables are connected via coded terminals.

Operating temperature range:

Non-Ex/Ex devices: -20 to 60 °C (-4 to 140 °F)

UL devices: -20 to 50 °C (-4 to 122 °F)

4.2 Dimensions

Observe the installation depth of approx. 150 mm (5.91 in) for the device incl. terminals and fastening clips.

In the case of devices with an Ex approval, the Ex frame is required and an installation depth of 175 mm (6.89 in) must be taken into consideration. For more dimensions please refer to the "Technical data" section.

- Panel cutout: 92 mm (3.62 in) x 45 mm (1.77 in).
- Panel thickness: max. 26 mm (1 in).
- Max. viewing angle range: 45° to the left and right from the central display axis.
- If the devices are arranged horizontally beside one another in the X-direction, or arranged vertically on top of one another in the Y-direction, the mechanical distance (specified by the housing and front section) must be observed.

4.3 Mounting procedure

The necessary panel cutout is 92 mm (3.62 in) x 45 mm (1.77 in)

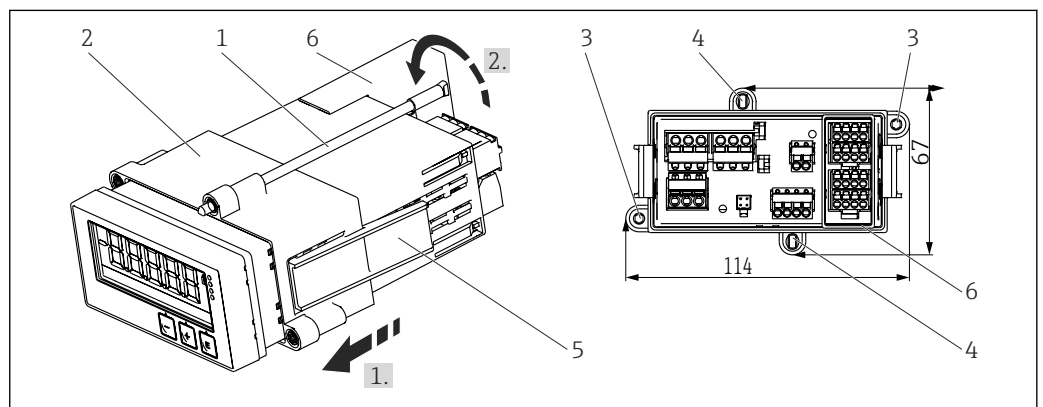

1 Installation in a panel

1. Screw the threaded rods (item 1) into the positions provided on the mounting frame (item 2). Four opposing screw positions (item 3/4) are available for this purpose.
2. Push the device through the panel cutout from the front.

3. To secure the casing in the panel, hold the device level and push the mounting frame (item 2), with the threaded rods screwed in, over the casing until the frame locks into position (1).
4. Then tighten the threaded rods to fix the device in place (2.).
5. For the Ex option, mount the spacer (item 6) for the terminals.

To remove the device, the mounting frame can be unlocked at the locking elements (item 5) and then removed.

4.4 Post-installation check

- Is the seal undamaged?
- Is the mounting frame securely fastened on the housing of the device?
- Are the threaded rods properly tightened?
- Is the device located in the center of the panel cutout?
- Is the spacer mounted (Ex option)?

5 Wiring

⚠ WARNING

Danger! Electric voltage!

- ▶ The entire connection of the device must take place while the device is de-energized.
- ▶ The protective ground connection must be established before all other connections. If the protective ground is disconnected, this can be a source of danger.
- ▶ Before commissioning the device, make sure that the supply voltage matches the voltage specifications on the nameplate.
- ▶ Provide suitable switch or circuit breaker in building installation. This switch must be provided close to the device (within easy reach) and marked as a circuit breaker.
- ▶ An overcurrent protection element (rated current $\leq 10\text{ A}$) is required for the power cable.

- i** ▪ Observe the terminal designation on the front of the device.
- The mixed connection of safety extra-low voltage and dangerous contact voltage to the relay is permitted.

5.1 Electrical connection

A loop power supply (LPS) is provided for every input. The loop power supply is primarily designed to supply power to 2-wire sensors and is galvanically isolated from the system and the outputs.

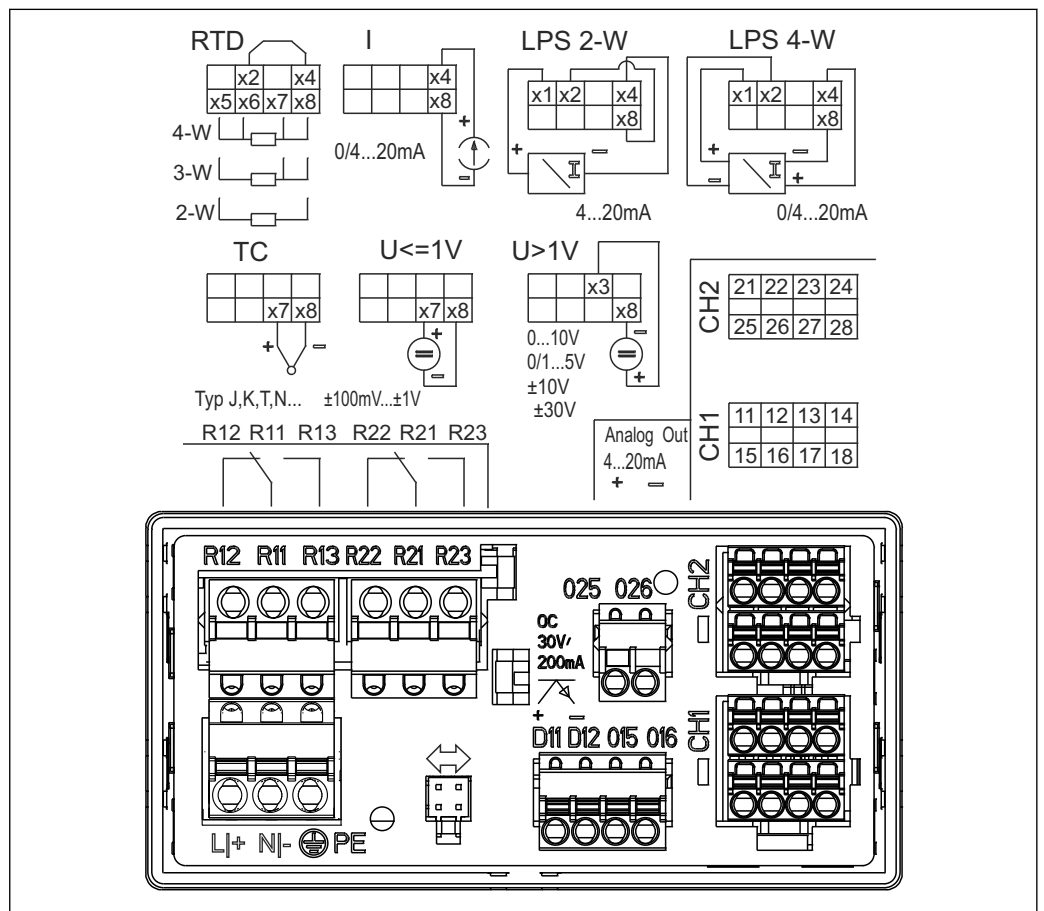

A0010228

2 Terminal assignment of device (channel 2 and relays optional). Note: Illustrated contact position of the relays if the power supply fails.

- i** We recommend you connect a suitable surge arrester upstream if high-energy transients can be expected on long signal cables.

5.1.1 Overview of possible connections on the process indicator

Terminal assignment of analog inputs, channel 1 and 2 (optional)									
CH1	11	12	13	14	CH2	21	22	23	24
	15	16	17	18		25	26	27	28

A0010406

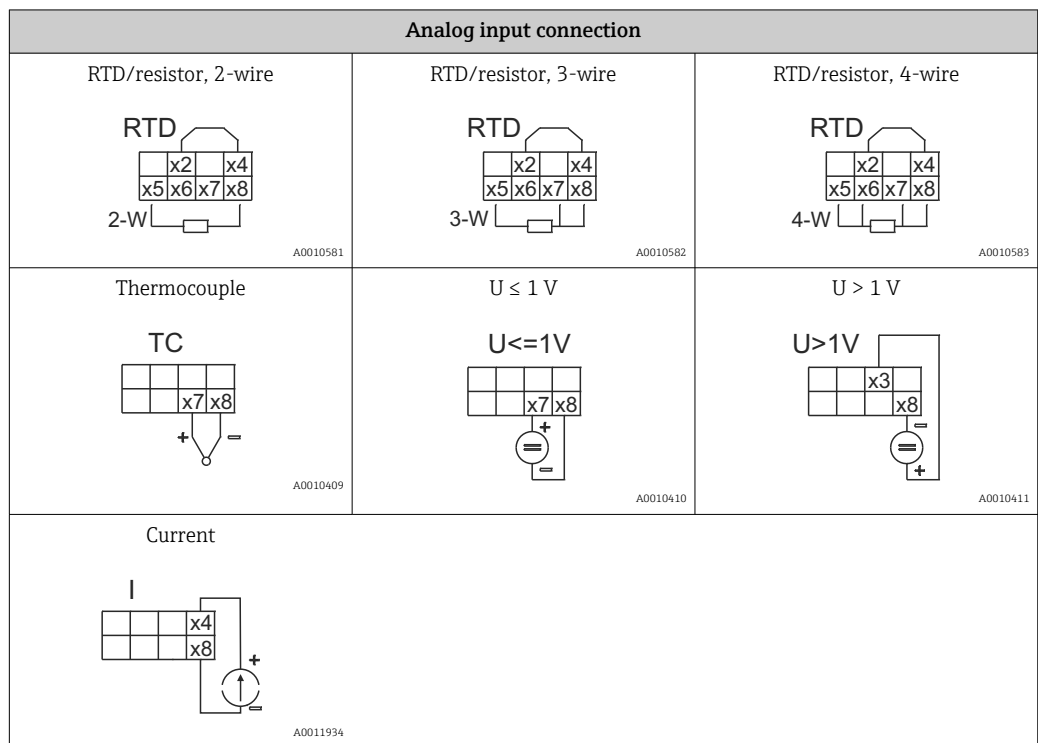
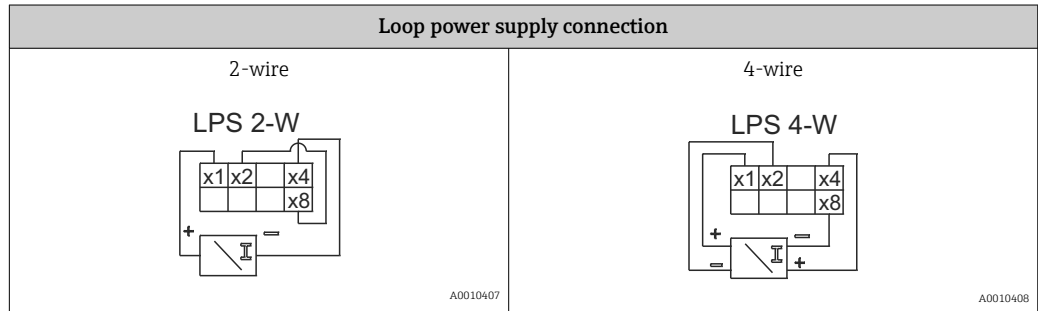

Illustrated contact position of the relays if the power supply fails:

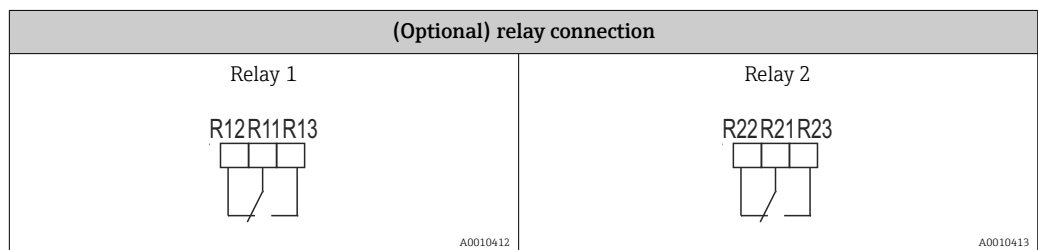

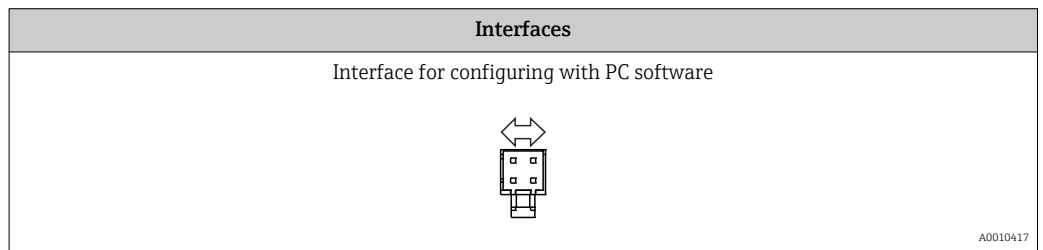
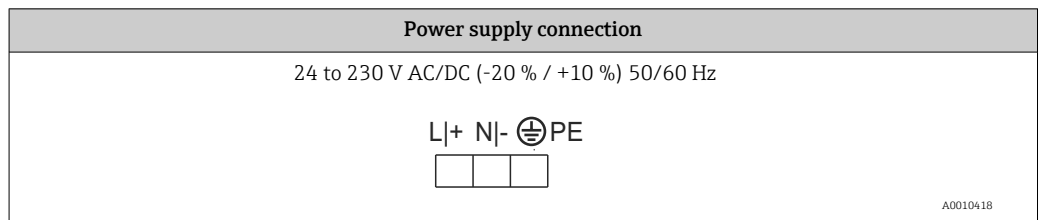
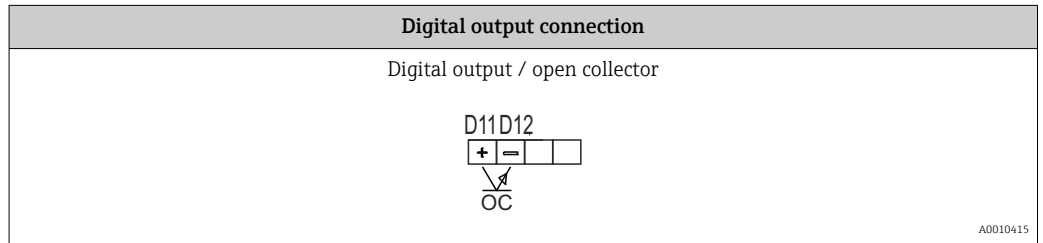
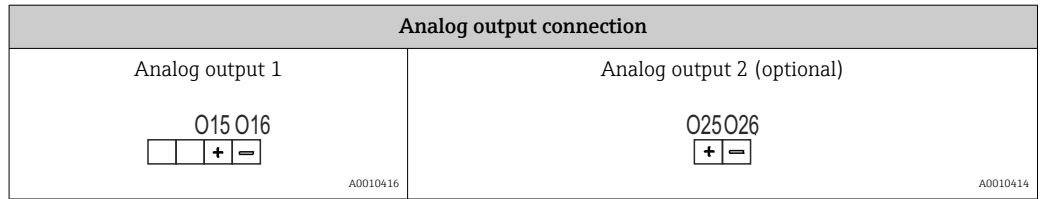

5.2 Post-connection check

Device condition and specifications	Notes
Are cables or the device damaged?	Visual inspection
Electrical connection	Notes
Does the supply voltage match the specifications on the nameplate?	24 to 230 V AC/DC (-20 % / +10 %) 50/60 Hz
Are all terminals firmly engaged in their correct slot? Is the coding on the individual terminals correct?	-
Are the mounted cables strain-relieved?	-
Are the power supply and signal cables correctly connected?	See the wiring diagram on the housing.

6 Operation

Thanks to the device's simple operating concept, it is possible to commission the device for many applications without a printed set of Operating Instructions.



The FieldCare operating software is a quick and convenient way of configuring the device. It contains brief explanatory (help) texts that provide additional information on individual parameters.

6.1 Operating elements

6.1.1 Local operation at the device

The device is operated by means of the three keys integrated in the front part of the device



	<ul style="list-style-type: none"> ▪ Open the Configuration menu ▪ Confirm an entry ▪ Select a parameter or submenu offered in the menu
	<p>Within the Configuration menu:</p> <ul style="list-style-type: none"> ▪ Scroll step-by-step through the parameters/menu items/characters offered ▪ Change the value of the selected parameter (increase or decrease) <p>Outside the Configuration menu:</p> <p>Display enabled and calculated channels, as well as min. and max. values for all the active channels.</p>

You can always exit menu items / submenus by selecting "x Back" at the end of the menu.

Leave the setup directly without saving the changes by pressing the '-' and '+' keys simultaneously for longer (> 3 s).

6.1.2 Configuration via interface & PC configuration software

⚠ CAUTION

Undefined states and switching of outputs and relays while configuring with the configuration software

- ▶ Do not configure the device when the process is running.

To configure the device using the FieldCare Device Setup software, connect the device to your PC. You need a special interface adapter for this purpose, e.g. the Commubox FXA291.

Installing the communication DTM in FieldCare

Before the indicator can be configured, FieldCare Device Setup must be installed on your PC. The installation instructions can be found in the FieldCare instructions.

Then install the FieldCare device driver according to the following instructions:

1. First install the device driver "CDI DTMLibrary" in FieldCare. It can be found in FieldCare under "Endress+Hauser Device DTMs → Service / Specific → CDI".
2. The DTM catalog in FieldCare must then be updated. Add the new installed DTMs to the DTM catalog.

Installation of the Windows driver for TXU10/FXA291

Administrator rights are required to install the driver in Windows. Proceed as follows:

1. Connect the device to the PC using the TXU10/FXA291 interface adapter.
 - ↳ A new device is detected and the Windows installation wizard opens.
2. In the installation wizard, do not allow the device to automatically search for software. For this, select "No, not this time" and click "Next".
3. In the next window, select "Install software from a list or specific location" and click "Next".
4. In the next window, click "Browse" and select the directory where the driver for the TXU10/FXA291 adapter is saved.
 - ↳ The driver is installed.
5. Click "Finish" to finish the installation.
6. Another device is detected and the Windows installation wizard starts again. Again, choose "No, not this time" and click "Next".
7. In the next window, select "Install software from a list or specific location" and click "Next".
8. In the next window, click "Browse" and select the directory where the driver for the TXU10/FXA291 adapter is saved.
 - ↳ The driver is installed.
9. Click "Finish" to finish the installation.

This completes the driver installation for the interface adapter. The COM port that has been assigned can be seen in the Windows device manager.

Establishing the connection

Proceed as follows to establish the connection with FieldCare:

1. Firstly, edit the connection macro. For this, start a new project and in the window that is displayed, right-click the symbol for "Service (CDI) FXA291" and select "Edit".
2. In the next window, to the right of "Serial interface", select the COM port which was assigned during the installation of the Windows driver for the TXU10/FXA291 adapter.
 - ↳ The macro is now configured. Select "Finish".
3. Start the "Service (CDI) FXA291" macro by double-clicking it and confirm the subsequent query with "Yes".
 - ↳ A search for a connected device is performed and the suitable DTM is opened. Online configuration is started.

Continue with device configuration in accordance with these Operating Instructions for the device. The complete Setup menu, i.e. all of the parameters listed in these Operating Instructions, can also be found in the FieldCareDevice Setup.

-  In general, it is possible to overwrite parameters with the FieldCare PC software and the appropriate device DTM even if access protection is active.

If access protection by means of a code should be extended to the software, this function should be activated in the extended device setup.

For this, select Menu → Setup / Expert → System → Overfill protect → German WHG and confirm.

6.2 Display and device status indicator / LED

The process indicator provides an illuminated LC display which is split into two sections. The segment section displays the value of the channel and additional information and alarms.

In the dot matrix section, additional channel information, such as the TAG, unit or bar graph, is displayed in the display mode. Operating text in English is displayed here during operation.

The parameters for configuring the display are described in detail in the "Configuring the device" section.

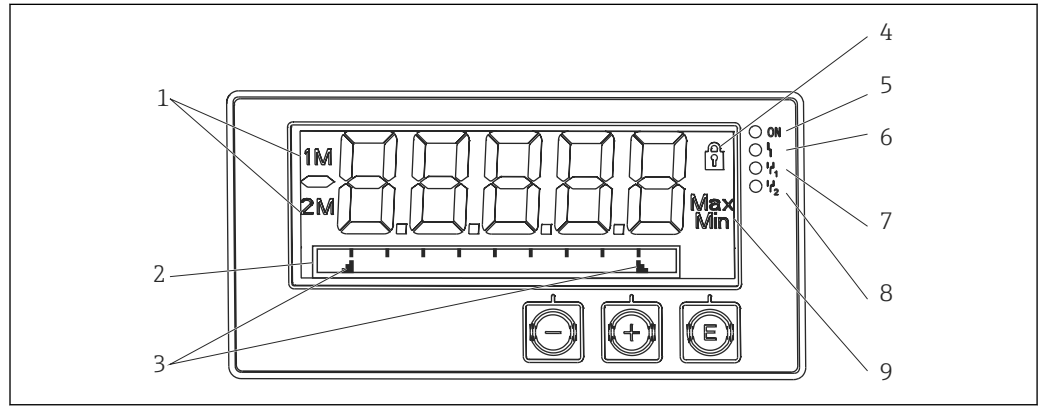

A0010223

3 Display of the process indicator

- 1 Channel indicator: 1: analog input 1; 2: analog input 2; 1M: calculated value 1; 2M: calculated value 2
- 2 Dot matrix display for TAG, bar graph, unit
- 3 Limit value indicators in the bar graph
- 4 "Operation locked" indicator
- 5 Green LED; on - supply voltage applied
- 6 Red LED; on - error/alarm
- 7 Yellow LED; on - relay 1 energized
- 8 Yellow LED; on - relay 2 energized
- 9 Minimum/maximum value indicator

In the event of an error, the device switches automatically between displaying the error and displaying the channel, → 37 and → 40.

6.3 Symbols

6.3.1 Display symbols

	The device is locked / operator lock; the device setup is locked for changes to parameters; the display can be changed.
1	Channel one (Analog in 1)
2	Channel two (Analog in 2)
1M	First calculated value (Calc value 1)
2M	Second calculated value (Calc value 2)
Max	Maximum value/value of the maximum indicator of the channel displayed
Min	Minimum value/value of the minimum indicator of the channel displayed

In the event of an error:

The display shows: -----, the measured value is not displayed

Underrange/overrange: - - - - -

 The error and the channel identifier (TAG) are specified in the dot matrix section.









6.3.2 Icons in the editing mode

The following characters are available for entering customized text:

'0-9', 'a-z', 'A-Z', '+', '-', '*', '/', '\', '%', '°', '2', '3', 'm', '.', ',', ';', ':', '!', '?', '_', '#', '\$', '@', ' ', '(', ')', '~'













For numerical entries, the numbers '0-9' and the decimal point are available.

Furthermore, the following icons are used in the editing mode:

	Symbol for setup
	Symbol for expert setup
	Symbol for diagnostics
	Accept entry. If this symbol is selected, the entry is applied at the position specified by the user, and you quit editing mode.
	Reject entry. If this symbol is selected, the entry is rejected and you quit editing mode. The previously set text remains.
	Jump one position to the left. If this symbol is selected, the cursor jumps one position to the left.
	Delete backwards. If this symbol is selected, the character to the left of the cursor position is deleted.
	Delete all. If this symbol is selected, the entire entry is deleted.

6.4 Quick guide to the operating matrix

The following tables list all the menus and the operating functions.

Display menu	Description
 AI1 Reset minmax*	Reset the min/max values for Analog in 1
 AI2 Reset minmax*	Reset the min/max values for Analog in 2
 CV1 Reset minmax*	Reset the min/max values for Calc value 1
 CV2 Reset minmax*	Reset the min/max values for Calc value 2
 Analog in 1	Display setting for analog input 1
 Analog in 2	Display setting for analog input 2
 Calc value 1	Display setting for calculated value 1
 Calc value 2	Display setting for calculated value 2
 Contrast	Display contrast
 Brightness	Display brightness
 Alternating time	Switchover time between values chosen to be displayed
 Back	Return to the main menu

*) Is only displayed if "Allow reset" = "Yes" is set in the "Expert" menu for the corresponding channel.

Setup menu		Description
☒	Application	Application selection
	1-channel	1-channel application
	2-channel	2-channel application
	Diff-pressure	Differential pressure application
+	AI1 Lower range*	Lower measuring range limit for Analog in 1
+	AI1 Upper range*	Upper measuring range limit for Analog in 1
+	AI2 Lower range*	Lower measuring range limit for Analog in 2
+	AI2 Upper range*	Upper measuring range limit for Analog in 2
+	CV Factor*	Factor for calculated value
+	CV Unit*	Unit for calculated value
+	CV Bar 0%*	Bar graph lower limit for calculated value
+	CV Bar 100%*	Bar graph upper limit for calculated value
+	Linearization*	Linearization for calculated value
	No lin points	Number of linearization points
	X-value	X-values for linearization points
	Y-value	Y-values for linearization points
+	Analog in 1	Analog input 1
	Signal type	Signal type
	Signal range	Signal range
	Connection	Connection type (only for Signal type = RTD)
	Lower range	Measuring range lower limit
	Upper range	Measuring range upper limit
	Tag	Designation of analog input
	Unit	Unit for analog input
	Temperature unit	Unit of temperature, only visible if "Signal type" = RTD or TC
	Offset	Offset for analog input
	Ref junction	Reference junction (only for Signal type = TC)
	Reset min/max	Reset min/max values for analog input
+	Analog in 2	Analog input 2
	See Analog in 1	
+	Calc value 1	Calculated value 1
	Calculation	Type of calculation
	Tag	Designation of calculated value
	Unit	Unit for calculated value
	Bar 0%	Bar graph lower limit for calculated value
	Bar 100%	Bar graph upper limit for calculated value
	Factor	Factor for calculated value
	Offset	Offset for calculated value
	No lin points	Number of points for linearization
	X-value	X-values for linearization points
	Y-value	Y-values for linearization points
	Reset min/max	Reset min/max values

*) Is only displayed if "Application" = "Diff pressure".

Setup menu		Description
	Calc value 2	Calculated value 2
	See Calc value 1	
+	Analog out 1	Analog output 1
	Assignment	Analog output assignment
	Signal type	Signal type, analog output
	Lower range	Lower range limit of analog output
	Upper range	Upper range limit of analog output
+	Analog out 2	Analog output 2
	See Analog out 1	
+	Relay 1	Relay 1
	Assignment	Assignment of value to be monitored with relay
	Function	Operating mode of the relay
	Set point	Limit value for relay
	Set point 1/2	Limit values 1 and 2 for relay (only if Function = Inband, Outband)
	Time base	Time base for gradient evaluation (only if Function = Gradient)
	Hysteresis	Hysteresis for relay
+	Relay 2	Relay 2
	See Relay 1	
+	Back	Return to the main menu

*) Is only displayed if "Application" = "Diff pressure".

Diagnostics menu		Description
Ⓜ	Current diagn	Current diagnostic message
+	Last diagn	Last diagnostic message
+	Operating time	Operating time of the device
+	Diagnost logbook	Diagnostics logbook
+	Device information	Device information
+	Back	Return to the main menu

Expert menu		Description
Ⓜ	Direct access	Direct access to an operating item
+	System	System settings
	Access code	Protection of operation by an access code
	Overfill protect	Overfill protection
	Reset	Device reset
	Save user setup	Save setup settings
+	Input	Inputs
	The following parameters are available in addition to the parameters from the Setup menu:	
	Analog in 1 / 2	Analog input 1 / 2
	Bar 0%	Lower limit for bar graph of analog input
	Bar 100%	Upper limit for bar graph of analog input

Expert menu		Description
	Decimal places	Decimal places for analog input
	Damping	Damping
	Failure mode	Failure mode
	Fixed fail value	Fixed value in the event of an error (only if Failure mode = Fixed value)
	Namur NE43	Error limits according to Namur
	Allow reset	Reset the min/max values via the Display menu
⊕	Output	Outputs
	The following parameters are available in addition to the parameters from the Setup menu:	
	Analog out 1 / 2	Analog output 1 / 2
	Fail mode	Failure mode
	Fixed fail value	Fixed value in the event of an error (only if Fail mode = Fixed value)
	Relay 1 / 2	Relay 1/2
	Time delay	Switching delay
	Operating mode	Operating mode
	Failure mode	Behavior in the event of an error

7 Commissioning

7.1 Post-installation check and switching on the device

Make sure that all post-connection checks have been carried out before putting your device into operation:

- Checklist for "post-installation check" →  12
- Checklist for "post-connection check" →  15

After the operating voltage is applied, the green LED lights up and the display indicates the device is ready for operation.

If you are commissioning the device for the first time, program the setup as described in the following sections of the Operating Instructions.

If you are commissioning a device that is already configured or preset, the device starts measuring immediately as defined in the settings. The values of the channels currently activated are shown on the display. Changes to the display can be made in the Display menu item →  33.

 Remove the protective film from the display as this would otherwise affect the readability of the display.

7.2 General information about configuring the device

You can configure your device onsite or put it into operation using the three integrated keys or via the PC. You require the Commubox FXA291/TXU10 (see the 'Accessories' section) to connect the device to a PC.

Advantages of configuring via FieldCare Device Setup:

- The device data are saved in FieldCare Device Setup and can be retrieved at any time.
- Data entry is faster with the keyboard.

7.3 Notes on setup access protection

Access to the setup is enabled by default (factory setting) and can be locked via the setup settings.

Proceed as follows to lock the device:







1. Press **E** to enter the configuration menu.
2. Press **+**, **Setup** is displayed.
3. Press **E** to open the **Setup** menu.
4. Repeatedly press **+** until **System** is displayed.
5. Press **E** to open the **System** menu.
6. **Access code** is displayed.
7. Press **E** to open the setting for access protection.
8. Set the code: press the **+** and **-** buttons to set the desired code. The access code is a four-digit number. The corresponding position of the number is displayed in plain text. Press **E** to confirm the value entered and go to the next position.



9. Confirm the last position of the code in order to exit the menu. The full code is displayed. Press **+** to scroll back to the last item of the **x Back** submenu and confirm this item. By confirming the point, the value is adopted and the display returns to the **Setup** level. Again select the last parameter **x Back** to also exit this submenu and return to the measured value/channel display level.

 The **x Back** item at the end of every picklist/menu item takes the user from the submenu to the next menu level up.

7.4 Device configuration

Configuration steps:

1. Selection of the application conditions (only for 2-channel device) →  24
2. Configuration of the universal input/inputs →  26
3. Configuration of calculations →  27
4. Configuration of the analog output/outputs →  28
5. Configuration of the relays (if option selected); assignment and monitoring of limit values →  28
6. Advanced device configuration (access protection/operating code; backup of current setup/user setup) →  32
7. Configuration of display functionalities →  33

The following section describes in detail how to set up the two-channel device and the differential pressure application package (brief overview of the configuration →  25, only available in the two-channel version). If you want to configure a single-channel device, please proceed as described in Step 2. →  26.

7.4.1 Step 1: Selecting the application conditions/number of active input channels

Application conditions for two-channel device

Call up the Setup menu after performing the post-installation check.

Press **E** → press **+** → **Setup** is displayed → press **E**.

Select your application conditions in the first item of the setup. You have a choice of the following settings:

- Differential pressure (Diff pressure): application package; parameters are automatically preselected for you.
- One-channel (1-channel): universal input 2 (Analog in 2) is deactivated (off) in the software. The second channel can be enabled any time via **Setup** → **Analog in 2** →  26.
- Two-channel (2-channel): universal input 1 (Analog in 1) and universal input 2 (Analog in 2) are pre-configured with the following values:
 - Signal type: **Current**
 - Signal range: **4-20mA**

A full description of the "Differential pressure" application package is provided in the following section.

To set up the device in single-channel/two-channel applications, please proceed with the device setup as explained in Step 2 →  26.

 If the application or the selected parameter are subsequently changed, parameters already configured are retained (e.g. if the differential pressure application is changed to two-channel, **Calc value 1** remains set to Difference).

Differential pressure application

A concise setup is available for differential pressure applications.

Once the differential pressure application setup has been completed successfully, the difference between the two inputs is automatically calculated and the signal linearized using the configured parameters of the analog inputs and the linearization points. As a result, the volume is already shown on the display (= calculated value 2).

- i** Prerequisites for correct value calculation and a functioning setup:
- Sensor 1 returns the higher pressure: connected to analog input 1 (Analog in 1)
 - Sensor 2 returns the lower pressure: connected to analog input 2 (Analog in 2)

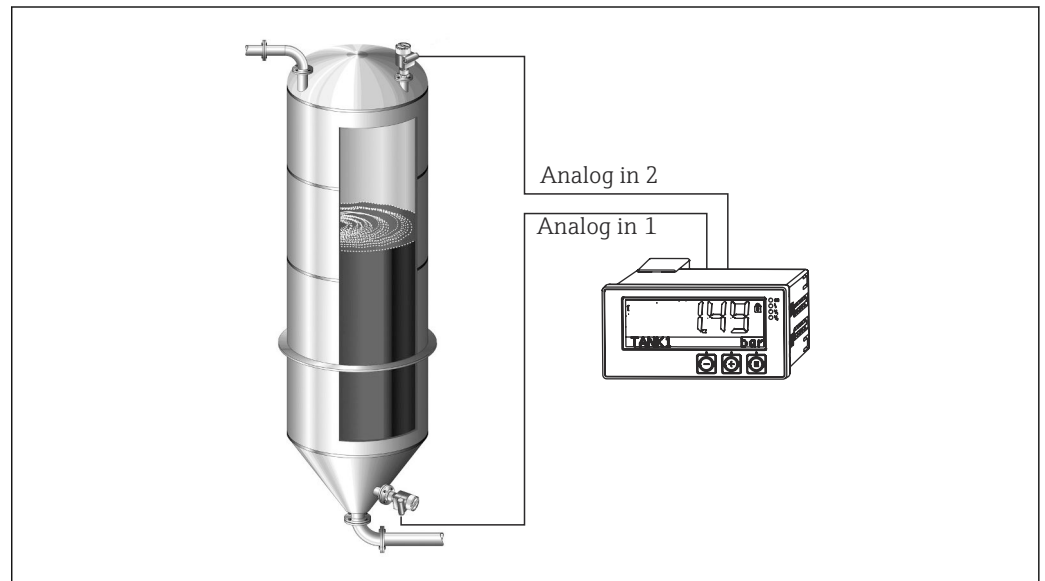

A0010350

4 Differential pressure application

Setup → Application → Diff pressure

Once the differential pressure application has been selected by confirming the **Diff pressure** parameter, the editable parameters are displayed in succession and must be configured individually for your application.

Some parameters are already configured for you due to the selection of the application setup → **26**.

The **CV Factor** parameter is used to take the density of the medium into account during level measurement, i.e. it corresponds to the mathematic formula $1/(\text{density} \cdot \text{gravitational acceleration})$. The default value for the factor is 1.

The density must be given in kg/m^3 and the pressure in Pascal (Pa) or N/m^2 . The gravitational acceleration is defined by the constant on the earth's surface.

This is $g=9.81 \text{ m}/\text{s}^2$. Tables and examples for converting application-related units into the defined values kg/m^3 and Pa or N/m^2 can be found in the Appendix → **54**.

- i** Other parameters can be enabled in the setup for the corresponding parameter (see Steps 4, 5, 6 and 7 or offset for analog inputs, display original values of analog channels, etc.).

‘Setup’ menu item

Setup → Application → ‘Diff pressure’	
Preconfigured by application package	Submenu
Setup analog inputs Signal: Current Range: 4-20 mA → 24 and → 26	AI1 Lower range: start of measuring range, analog input 1 (corresponds to 4 mA for example)
	AI1 Upper range: end of measuring range, analog input 1 (corresponds to 20 mA for example)
	AI2 Lower range: start of measuring range, analog input 2 (corresponds to 4 mA for example)
	AI2 Upper range: end of measuring range, analog input 2 (corresponds to 20 mA for example)
Setup display Display: calculated value and bar graph for Calc Value 2: Active; all other values inactive → 33	CV Unit: unit of the calculated volume value (e.g.liters)
	CV Bar 0%: start of measuring range for bar graph display
	CV Bar 100%: end of measuring range for bar graph display
CV Factor	CV Factor: factor to take the density of the medium into account during level measurement, i.e. it corresponds to the mathematic formula $1/(\text{density} \cdot \text{gravitational acceleration})$; default value: 1
Setup calculation of the volume: Calc value 1: Difference Calc value 2: Lineariz. CV1 → 27	Create the linearization table: If the volume value should be calculated - i.e. a linearization of the difference is output - the X and Y coordinates must be specified as the basis for performing the calculation.
	No lin points: number of linearization points required (max. 32)
	X-value: X-coordinate for linearization point X1, 2, etc.
	X-value: Y-coordinate for linearization point X1, 2, etc.
	End differential pressure setup

7.4.2 Step 2: Configuring the universal input(s) (Analog in 1/2)

The device has one universal input, and optionally an additional universal input for current, voltage, resistance thermometers (RTD) or thermocouples (TC).

The input is monitored for a cable open circuit (see the 'Measuring range limits' table → 37 and the 'Troubleshooting' section → 40).

Minimum/maximum values at the inputs:

The current min./max. value is saved every 15 minutes. If the power supply is disconnected (power off/power on), there may be a gap in the recording sequence. The measuring interval starts when the device is switched on. It is not possible to synchronize the measuring cycles to full hours.

Limit values and relays are available for monitoring the measured values. They must be configured as described in Step 5 → 28.

Each universal input saves the smallest and largest measured value that is measured. These values can be reset individually for every channel. In the setup, the administrator can specify that a user can reset the minimum and maximum values of the individual channels directly in the main menu without the need for a release code. The min./max. value is reset if a reset is performed and if channel scaling is changed.

Setup
Analog in 1 Analog in 2

Current	Voltage	RTD (resistance temperature detector)	TC (thermocouple)	Off (deactivate the input)
Signal range Signal range (see Technical data); start and end of measuring range defined by the type selected				
Lower range Start of measuring range; also enter the decimal point		Connection (RTD only) Type of connection (2-, 3-, 4-wire connection)		
Upper range End of measuring range; also enter the decimal point				
TAG Channel identifier				
Unit Unit				
Offset Constant value that is added to the current measured value			Ref junction (TC only) Internal/fixed + entry of "Fixed ref junction"	
Res minmax: (yes/no) Reset minimum/maximum values?				

7.4.3 Step 3: Configuring the calculations

One channel or two channels (optional) with the following functions are available for calculations:

Setup	
Calc value 1	Calc value 2
<ul style="list-style-type: none"> ▪ Switched off ▪ Sum (AI1+AI2) ▪ Difference (AI1-AI2) ▪ Average ((AI1+AI2)/2) ▪ Linearization AI1 ▪ Multiplication (AI1*AI2) 	<ul style="list-style-type: none"> ▪ Switched off ▪ Sum (AI1+AI2) ▪ Difference (AI1-AI2) ▪ Average ((AI1+AI2)/2) ▪ Linearization AI2 ▪ Linearization CV1 ▪ Multiplication (AI1*AI2)
TAG Unit Bar 0% Bar 100% Factor Offset	To be configured like the universal input, see Step 2 → 26
No. lin points → X/Y coordinates The device has two linearization tables, each with a maximum of 32 linearization points. They are permanently assigned to the 'Calc value 1' and 'Calc value 2' channels. If linearization is selected as the calculation, the number of linearization points needed is specified in the 'No. lin points' parameter. An X-coordinate and a Y-coordinate must be specified for each linearization point. The linearization tables can be deactivated individually.	
Reset min/max	To be configured like the universal input, see Step 2 → 26

7.4.4 Step 4: Configuring the analog output(s)

The device has one analog output (optionally two analog outputs). These outputs can be freely assigned to the inputs and channels available in the device.

Setup	
Analog out 1 Analog out 2	
Assignment: assignment of the output <ul style="list-style-type: none"> ▪ Off: switched off ▪ Analog input 1: universal input 1 ▪ Analog input 2: universal input 2 ▪ Calc value 1: calculated value 1 ▪ Calc value 2: calculated value 2 	
Signal type: select active signal range of the output	The output range for the current output corresponds to Namur NE43, i.e. a range to 3.8 mA or 20.5 mA is used. If the value continues to increase (or continues to drop), the current remains at the limits 3.8 mA or 20.5 mA. 0-20 mA output: only the overrange is available. An overrange is also only available for the voltage output. The limit of the overrange is 10% here.
Lower range Upper range	To be configured like the universal input, see Step 2 → 26

7.4.5 Step 5: Configuring the relays, assigning and monitoring limit values

As an option, the device has two relays with limit values, which are either switched off, or can be assigned to the input signal or the linearized value of analog input 1 or 2 or the calculated values. The limit value is entered as a numerical value including the decimal position. Limit values are always assigned to a relay. Each relay can be assigned to a channel or a calculated value. In the "Error" mode, the relay functions as an alarm relay and switches each time a fault or alarm occurs.

The following settings can be made for each of the two limit values: assignment, function, set point, hysteresis, switching behavior ¹⁾, delay ¹⁾ and failure mode ¹⁾.

Setup	
Relay 1 Relay 2	
Assignment: Which value should be monitored?	Off , Analog input 1, Analog input 2, Calc value 1, Calc value 2, Error
Function: Operating mode of the relay (for a description, see the "Operating modes" → 29)	Min, Max, Gradient, Out-band, In-band
Set point: Set point 2: Limit value	Enter the limit value with the position of the decimal point. Set point 2 is only displayed for out-band and in-band.

1) Can only be set via the Expert menu, Expert/Output/Relay

Time base: Time base for calculating the gradient	Enter the time base in seconds. Only for the Gradient operating mode.
Hysteresis: Hysteresis. For every set point, the switch point can be controlled via a hysteresis.	The hysteresis is configured as an absolute value (only positive values) in the unit of the particular channel (e.g. upper limit value = 100 m, hysteresis = 1 m: limit value on = 100 m, limit value off = 99 m)

- i
 Please note special situations where both the hysteresis and the delay time should be activated simultaneously (see the following description in the "Operating modes" section).
- Following a power failure, the limit value monitoring system behaves as if the limit value had not been active before the power failure, i.e. the hysteresis and any delay are reset.

Relay specification

Relay contact	Changeover
Maximum contact load DC	30 V / 3 A (permanent state, without destroying the input)
Maximum contact load AC	250 V / 3 A (permanent state, without destroying the input)
Minimum contact load	500 mW (12 V / 10 mA)
Galv. isolation towards all other circuits	Test voltage 1 500 V _{AC}
Switching cycles	> 1 million
Default setting	Normally closed: NC contact Rx1/Rx2

Operating modes

Off

No action is triggered. The assigned output is always in the normal operating state.

Min (lower limit value)

The limit is active if the value drops below the configured value. The limit value is switched off if the limit value, including hysteresis, is exceeded.

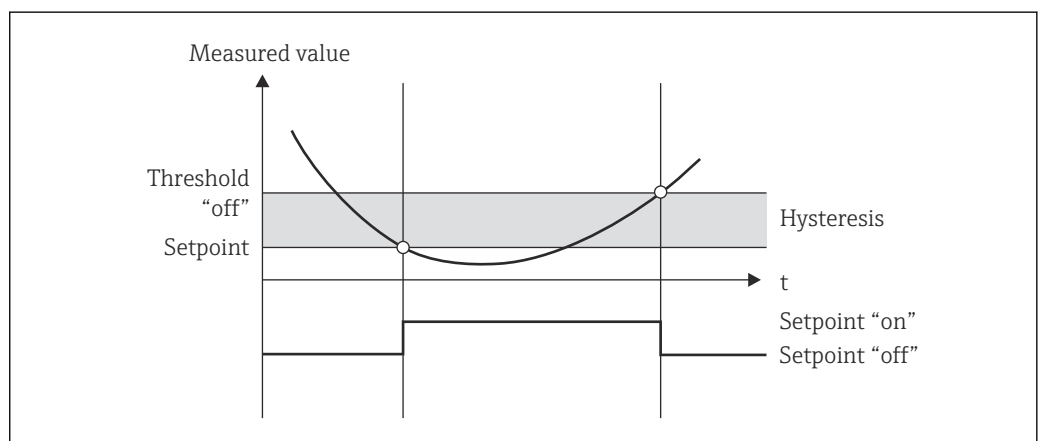

5 Min operating mode

A0048460

Max (upper limit value)

The limit value is active if the value exceeds the configured value. The limit value is switched off if the limit value, including hysteresis, is undershot.

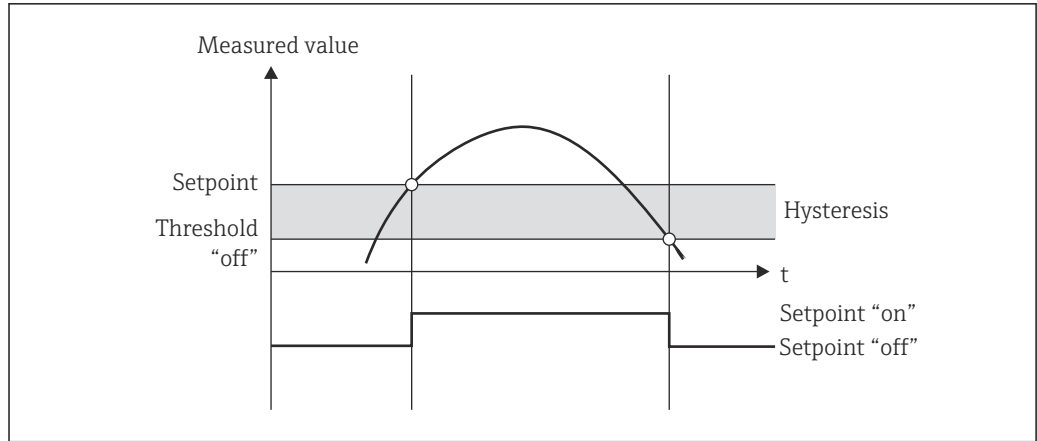

A004B461

6 Max operating mode

Gradient

The "Gradient" operating mode is used to monitor the change of the input signal over time. The alarm is triggered if the measured value reaches or exceeds the preset value. If the user configures a positive value, the limit value is monitored for increasing gradients.

In the case of negative values the decreasing gradient is monitored.

The alarm is canceled when the gradient drops below the preset value. A hysteresis is not possible in the Gradient operating mode. The alarm can be suppressed for the set time delay (unit: seconds s) in order to decrease the sensitivity.

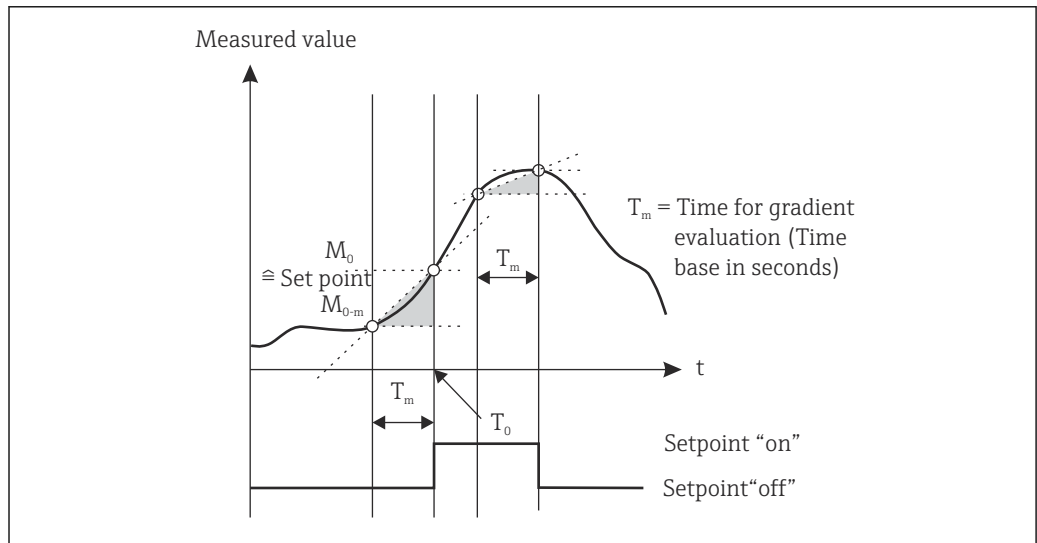

A004B462

7 Gradient operating mode

OutBand

The limit value is violated as soon as the measured value to be checked lies within a preset band between minimum and maximum. The hysteresis must be monitored on the outside of the band.

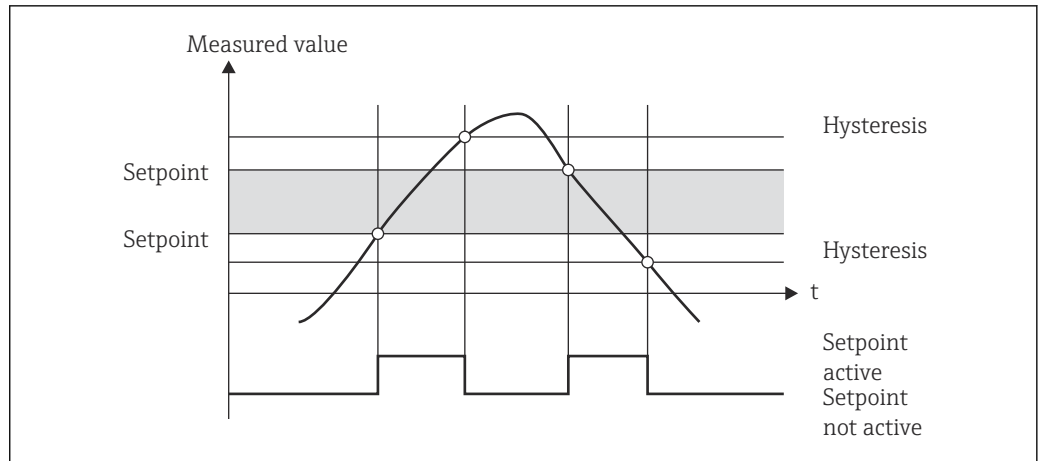

8 OutBand operating mode

InBand

The limit value is violated as soon as the measured value to be checked exceeds or drops below a preset maximum or minimum respectively. The hysteresis must be monitored on the inside of the band.

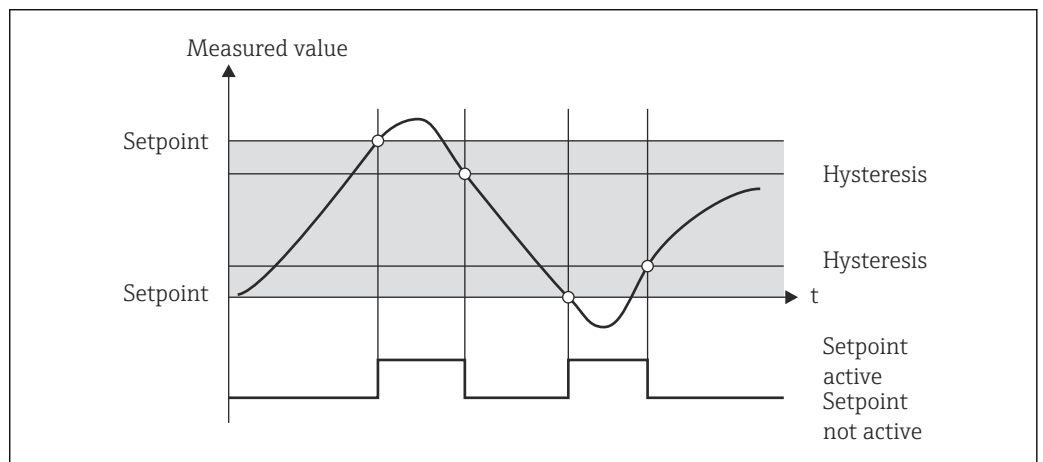

9 InBand operating mode

Special case: Hysteresis and delay for one limit value

In the special scenario where the hysteresis and limit value delay are activated, a limit value is switched according to the following principle.

If the hysteresis and the limit value delay are activated, the delay becomes active when a limit value is exceeded and measures the time since the start of limit value overshoot. If the measured value falls below the limit value, the delay is reset. This also occurs if the measured value falls below the limit value, but continues to be higher than the set hysteresis value. When the limit value is exceeded again, the delay time becomes active again and starts measuring from 0.

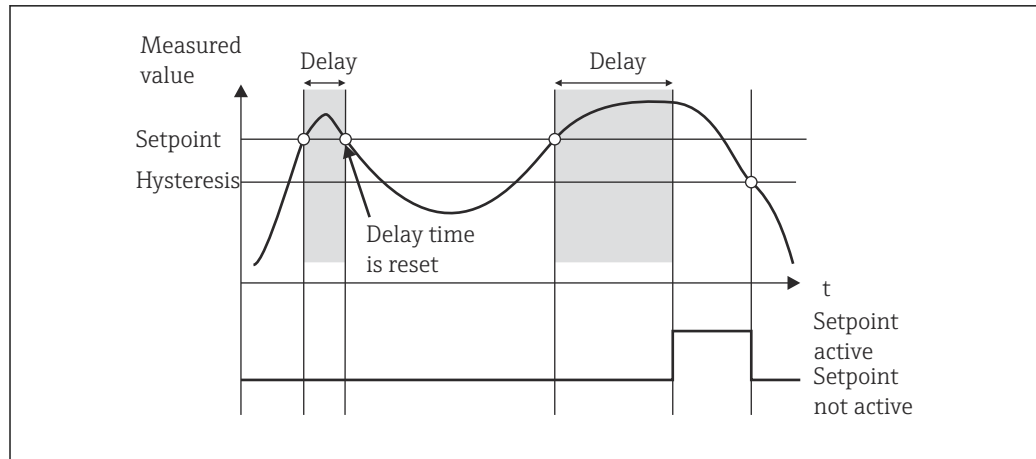

10 Hysteresis and delay active

7.4.6 Step 6: Advanced device configuration (access protection/operating code, saving the current setup)

Access protection

Access protection locks all the editable parameters, i.e. the setup can only be accessed once the 4-digit user code has been entered.

Access protection is not activated at the factory. However, the configuration of the device can be protected by a four-digit code.

Activating access protection

1. Call the menu 'Setup' → 'System' → 'Access code'
2. To enter the code with the '+' and '-' keys, select the desired character and press 'E' to confirm. The cursor goes to the next position.
 - ↳ After confirming the fourth position, the entry is accepted and the user exits the 'Access code' submenu.

Once access protection has been successfully activated, the lock symbol appears on the display.

i If access protection is enabled, the device locks automatically after 600 seconds if the device has not been operated during this time. The display switches back to the operating display. To delete the code completely, use the '+' and '-' keys to select the "c" character and press 'E' to confirm.

Saving the current setup/user setup

The current device configuration can be saved and is therefore available as a specific setup for a device reset or for a device restart. If you ordered the device with customized settings, the preconfigured setup is also saved in the user setup.

Saving the setup

1. Call the menu 'Expert' → 'System' → 'Save User Setup'.
2. Confirm by selecting 'yes'.

i See also "Device reset" → 38.

7.4.7 Step 7: Configuring the display functions

The display is split into a 7-segment display section and a color section. The dot matrix section can be configured separately for each channel.

Users can choose from all the active channels (analog inputs and calculated values).

Configuration of the display

1. Press 'E'
2. Select 'Display'.
3. Select channel/calculated value and configure one of the parameters that follow.

Off	Channel is not displayed.	
Activate the display by configuring the color section		
	Value/measured value of the channel is displayed on the 7-segment display.	
	Unit	The unit of the channel is displayed
	Bar graph	The value of the channel is displayed as a bar graph over the entire width.
	Bargr+unit	Division of the color section, displays value of the channel as a bar graph and unit of the channel
	TAG+unit	Division of the color section, displays channel name and unit of the channel

- **Contrast:** select contrast (can be configured in steps of 1 to 7)
- **Brightness:** select brightness (can be configured in steps of 1 to 7)
- **Alternating time:** select the time between automatic switchover between the channels and calculated values (in seconds: 3, 5, or 10)
- **x Back** takes you back to the menu one level up.

 If several channels are active, the device switches automatically between the channels configured.

Non-activated channels, calculated values and minimum and maximum values are called up manually by pressing the '+' and '-' keys and appear for 5 seconds on the display.

7.4.8 Overfill protection

The German Water Resources Act (WHG) requires the use of overfill protection units on vessels for water-polluting liquids. These units monitor the level and trigger an alarm in time before the permitted fill level is reached. According to the approval guidelines for overfill protection units (ZG-ÜS), suitable plant units must be used for this.

In accordance with these guidelines, the device can be used as a limit signal transmitter for overfill protection units with continuous level measurement for storing liquids which are hazardous to water (water-polluting liquids).

As a prerequisite the device must comply with the general and special construction principles (chapters 3 and 4) of the approval guidelines for overfill protection units. This means that the safety-oriented message "Maximum level" is displayed (the limit relay de-energizes) in the following situations:

- in the event of power supply failure and
- if limit values are exceeded or undershot and
- if the connection cables between the upstream transmitter and the limit signal transmitter are disconnected.

In addition, the configured limit values for overfill protection must be secured against unintentional modification.

i The following function must be activated if additional access protection should be provided for the configuration software:

Select **Setup / Expert** → **System** → **Overfill protect: German WHG**

Configuration when operating the device in accordance with the approval guidelines for overfill protection units:

The device must be set up and operated in accordance with these Operating Instructions pertaining to the device.

- Universal inputs must be configured (like in Step 1 - Step 3 → 24).
- Limit values must be configured as follows (like Step 5 → 28):

Function: MAX

Assignment: which input signal should be monitored?

Set point: maximum limit value to be monitored; value for the switching threshold

Hysteresis: no hysteresis (=0)

Time delay¹⁾: no switching delay (=0) or the set time must be taken into account for the tail quantity

- The device must be locked for unauthorized persons;

User Code protects the configured parameters (like Step 6 → 32):

Enter the 4-digit code: select digit with '+' or '-' and press 'E' to confirm the individual digit; once the digit has been confirmed, the cursor moves to the next position, or skips back to the 'System' menu item once the fourth digit has been entered

The lock symbol appears on the display.

- Select **Setup** → **System** → **Overfill protect: German WHG**.

It is absolutely essential to assign the device to a WHG application. Confirming the 'Overfill protect: German WHG' parameter provides additional safety. The device status must be changed if the device is being configured using the FieldCare operating software, i.e. WHG must be disabled to be able to change parameters.

1) Can only be configured in the "Expert" menu

7.4.9 Expert menu

You activate the Expert mode by pressing **E** → **Expert**.

The Expert menu offers advanced device settings to adapt the device optimally to the application conditions.

Access to the Expert menu requires an access code. The factory default code is "0000". If a new access code is defined by the user, it replaces the access code assigned at the factory.

The Expert menu is enabled as soon as the correct access code has been entered.

The configuration options which the Expert mode also offers in addition to the normal setup parameters are described in the following section.

Input → **Analog input 1/2**

Bar 0%, Bar 100%

Change the scaling of the bar graph; default value: channel scaling

Decimal places

Specify the desired number of decimal places; default value: 2 decimal places

Damping

The input signal can be dampened by a low-pass filter.

The damping is specified in seconds (can be configured in steps of 0.1 s , max. 999.9 s).

Default values

Input type	Default value
Current and voltage inputs	0.0 s
Temperature inputs	1.0 s

Once 5 times the filter time has elapsed, 99% of the actual measured value is reached.

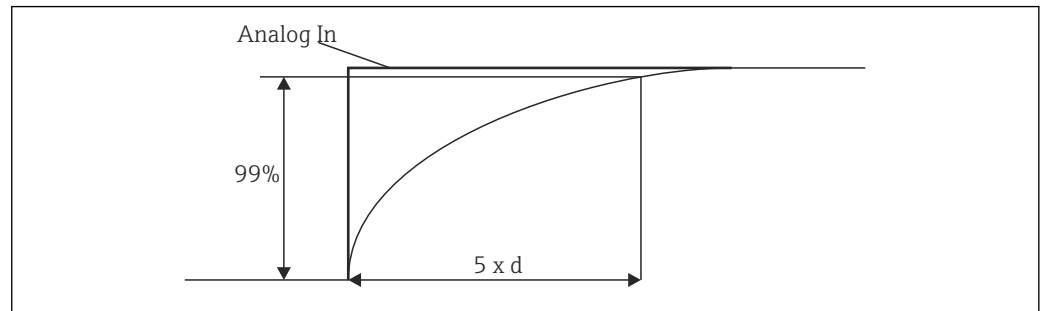

A0010508

11 Signal damping

Analog In: Analog input signal

d: Set damping

Failure mode

If an error is detected at one of the two inputs, the internal status of the input is set to error. The behavior of the measured value in the event of an error can be defined here.

- Invalid = invalid value:
The value is not calculated further as it is passed on as an invalid value.
- Fixed value = constant value:
A constant value can be entered. This value is used if the device should perform further calculations. The input continues to be in the "error" state.

Namur NE43

Only for 4 to 20 mA. The measured value and the cables are monitored in accordance with NAMUR NE43 recommendations. See → 37. Default value: enabled

Open circ detect

Only for 1 to 5 V. Input monitored for cable open circuit.

Failure delay

Delay time for failures, 0 to 99 s

Allow reset

If this function is activated, the min. and/or max. values can be reset outside the setup in the Display menu. Active access protection does not apply when this memory is reset.

Output → Analog output 1/2

Failure mode

- Min = stored minimum value:
The stored minimum value is output.
- Max = stored maximum value:
The stored maximum value is output.
- Fixed value = constant value:
It is possible to enter a constant value that is output in the event of an error.

Output → Relay 1/2*Time delay*

Sets the time delay for switching the relay

Operating mode

Operating mode of the relay.

- norm opened
- norm closed

Failure mode

- norm opened
- norm closed

NOTICE**Setting the limit relay failure mode**

- ▶ The failure mode of the limit relay is configured in the setup. If an error occurs at an input to which a limit value is assigned, the limit relay adopts the configured status. The effect of the limit relay in the event of an error (energizes or de-energizes) must be specified in the setup. If a failure mode with a fixed error substitute value is configured in the assigned input, the corresponding relay does not react to the error at the input. Instead it checks the substitute value for limit value violation and switches depending on the limit value violation. The default value for the relay is "energized".

Application → Calc value 1/2*Failure mode*

- Invalid:
The calculated value is not valid and is not output.
- Fixed value:
It is possible to enter a constant value that is output in the event of an error.

Diagnostics*Verify HW set*

Following a hardware upgrade (e.g. additional relays, universal inputs etc.), it is necessary to perform hardware verification, i.e. the hardware is checked by the firmware in the device.

The "Verify HW set" function must be enabled in this case.

Simulation

The output value of the analog outputs and the switching state of the relays can be specified in the simulation mode. Simulation remains active until it is set to "off". The start and end of the simulation are saved in the diagnostic events.

Expert → Diagnostics → Simulation:

- Select the output to be simulated with the simulation value
- Select the relay to be simulated with the status

7.5 In operation

7.5.1 + and - quick pick keys

You can use the '+' and '-' quick pick keys to switch through all the active channels (universal inputs and calculated values) in the display mode. The measured value or the calculated value is then displayed for 5 seconds. The channel name pertaining to the value

displayed appears in the color section of the display. The maximum and minimum value are provided for each active channel.

Press the '+' and '-' simultaneously to exit a menu at any time. Any changes made are not saved.

7.5.2 Min/Max memory



The device records the highest and lowest values of the inputs and calculated values and saves them cyclically every 15 minutes in the nonvolatile memory.

Display:

Select the corresponding channel using the '+' and '-' quick pick keys.

Reset the min. and max. values:

Reset in the setup: select the channel (Analog in 1/2, Calc value 1/2), 'Reset min/max', min./max. values of the corresponding channel are reset.

 A reset outside the setup (resetting without a user code) is only possible if this has been enabled for the channel in the setup (Allow reset →  26). Press 'E' and select 'Display'. All the channels for which resetting outside the setup is permitted are displayed in succession. Select the corresponding channel and set to 'yes'. The channel is reset.

7.5.3 Device self-diagnosis, failure mode and cable open circuit detection/measuring range limits

The device monitors its inputs for a cable open circuit, as well as its own internal functions, by comprehensive monitoring mechanisms in the device software (e.g. cyclic memory test).

If the device self-diagnosis function detects an error, the device reacts as follows:

- Open collector output switches
- Red LED is lit
- Relay switches (if active and assigned as a fault/alarm relay)
- Display goes to error mode → color of channel affected changes to red and an error is displayed
- Display switches automatically between the active channels and the error

Troubleshooting instructions and a list of all the error messages can be found in the 'Troubleshooting' section →  40.

Measuring range limits

Display							
Display	-----	-----	Measured value	-----	-----	-----	Points to note
Status	F	F	Displayed and processed measured value	F	F	F	
Range		Under range		Over range		Invalid measured value	
0 to 20 mA			0 to 22 mA	> 22 mA		Not calibrated	Negative currents are not displayed or calculated (value remains at 0)
4 to 20 mA (without Namur)		≤ 2 mA	> 2 mA < 22 mA	≥ 22 mA		Not calibrated	
4 to 20 mA (as per Namur)	≤ 2 mA ¹⁾ 2 < x ≤ 3.6 mA ²⁾	> 3.6 mA to ≤ 3.8 mA	> 3.8 mA to < 20.5 mA	≥ 20.5 mA... < 21 mA	≥ 21 mA ²⁾	Not calibrated	As per NAMUR 43
+/- voltage ranges		< -110%	-110%...110%	> 110%		Not calibrated	

Display							
Display	-----	-----	Measured value	-----	-----	-----	Points to note
Status	F	F	Displayed and processed measured value	F	F	F	
Range		Under range		Over range		Invalid measured value	
Voltage ranges from 0 V		< -10%	-10%...110%	> 110%		Not calibrated	
	No further calculation/further calculation with fixed error value		Further calculation in math and as min./max.				
Voltage range 1 to 5 V with activated cable open circuit detection	≤ 0.8 V		1 to 5 V		≥ 5.2 V	Not calibrated	
Thermocouples	Below the lower range limit ²⁾		0 to 100%		Above the upper range limit ²⁾		Cable open circuit detection from approx. 50 kΩ ¹⁾
Resistance	Below the lower range limit ¹⁾		0 to 100%		Above the upper range limit ¹⁾		
	No further calculation/further calculation with fixed error value		Further calculation in math and as min./max.	No further calculation/further calculation with fixed error value			

1) Cable open circuit

2) Error at sensor

7.5.4 Saving diagnostic events/alarms and errors

Diagnostic events such as alarms and fault conditions are saved in the device as soon as a new error occurs or the status of the device changes. The events saved are written to the nonvolatile device memory every 30 minutes.

The device lists the following values in the 'Diagnostics' menu:

- Current device diagnostics
- Last device diagnostics
- Last 5 diagnostic messages

List of error codes, see Troubleshooting →  40.

 It is possible that events saved over the past 30 minutes might be lost.

7.5.5 Operating hours counter

The device has an internal operating hours counter which also acts as the reference for diagnostic events.

The operating hours are indicated in the 'Diagnostics' → 'Operating time' menu item. This information cannot be reset or changed.

7.5.6 Device reset

Various reset levels are available for a device reset.

'Expert' → 'System' → 'Reset' → 'Factory reset': reset all the parameters to the as-delivered state; all the configured parameters are overwritten.

 If a user code has been defined, it is overwritten!!! When operation is locked by a user code, this is indicated by a lock symbol on the display.

'Expert' → 'System' → 'Reset' → 'User reset': parameters are loaded and configured in accordance with the user setup that is saved; the current configuration or factory settings are overwritten by the user setup.

 If a user code has been defined, it is overwritten by the user code defined in the user setup!!! If no user code was saved in the user setup, the device is no longer locked. When operation is locked by a user code, this is indicated by a lock symbol on the display.

8 Diagnostics and troubleshooting

To help you troubleshoot, the following section is designed to provide an overview of possible causes of errors.

NOTICE

Device malfunction possible when retrofitting with untested hardware



- ▶ When retrofitting the device with additional hardware (relay, additional universal input and additional analog output), the device software must perform an internal hardware test). To do so, call up the "Verify HW set" function in the Expert→Diagnostics menu.

8.1 General troubleshooting

⚠ WARNING

Danger! Electric voltage!

- ▶ Do not operate the device in an open condition for device troubleshooting.

i Error codes that appear on the display are described in the next section →  40. Further information on the failsafe mode is also provided in the "Commissioning" section →  37.

8.2 Overview of diagnostic information

i Faults have the highest priority. The corresponding error code is displayed.

8.3 Diagnosis list

The errors are defined as:

Error code	Meaning	Remedy
F041	Sensor/cable open circuit	Check wiring
F045	Sensor error	Check sensor
F101	Below range	Check measurement, limit value violated
F102	Above range	
F221	Error: Reference junction	Contact your service organization.
F261	Error: Flash	Contact your service organization.
F261	Error: RAM	Contact your service organization.
F261	Error: EEPROM	Contact your service organization.
F261	Error: A/D converter, channel 1	Contact your service organization.
F261	Error: A/D converter, channel 2	Contact your service organization.
F261	Error: invalid device ID	Contact your service organization.
F281	Initialization phase	Contact your service organization.
F282	Error: parameter data could not be saved	Contact your service organization.
F283	Error: incorrect parameter data	Contact your service organization.
F431	Error: incorrect calibration values	Contact your service organization.
C411	Info: upload/download active	For information purposes only. Device is working properly.
C432	Info: calibration/test mode	For information purposes only. Device is working properly.

Error code	Meaning	Remedy
C482	Info: simulation mode, relay/open collector	For information purposes only. Device is working properly.
C483	Info: simulation mode, analog output	For information purposes only. Device is working properly.
C561	Display overrun	For information purposes only. Device is working properly.

9 Maintenance

No special maintenance work is required for the device.

9.1 Cleaning

A clean, dry cloth can be used to clean the device.

10 Repair

10.1 General notes

i Repairs that are not described in these Operating Instructions must only be carried out directly by the manufacturer or by the service department.

If ordering spare parts, specify the serial number of the device. Where necessary, installation instructions are supplied with the spare part.

10.2 Spare parts

Device spare parts that are currently available can be found online at:
<https://www.endress.com/en/instrumentation-services>.

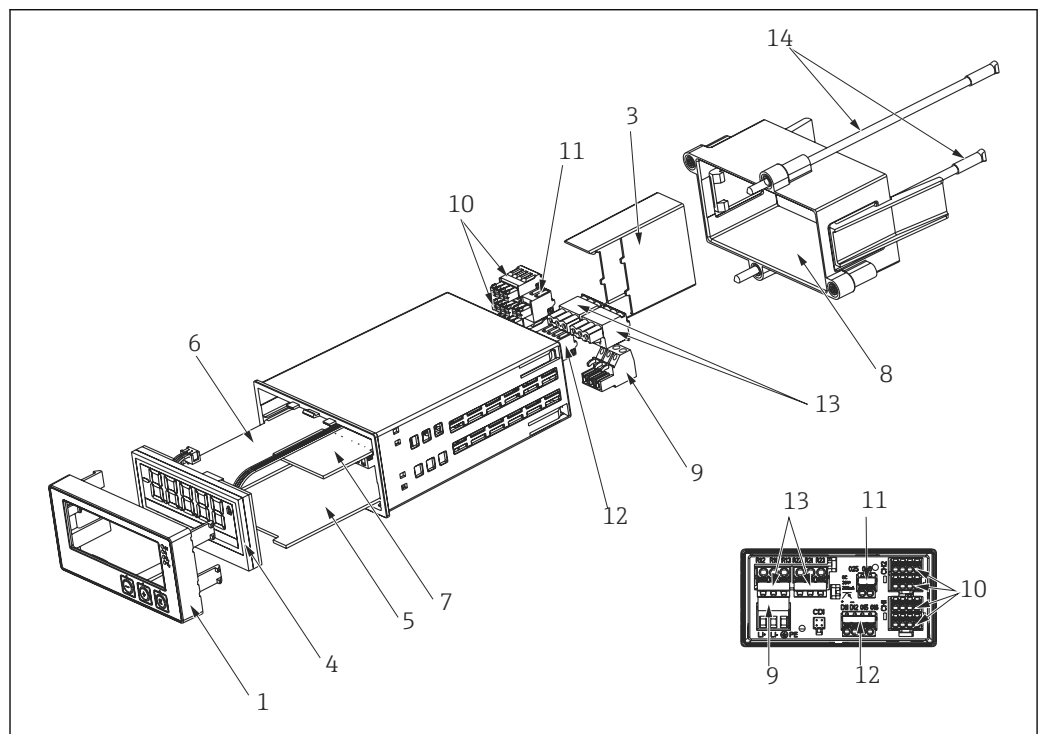

A0010213

12 Spare parts

Item No.	Designation
1	Housing front with front foil (incl. keyboard)
3	Ex terminal cover
4	CPU with LCD display
5	Mainboard Mainboard 20-250 VDC/AC non-Ex Mainboard 20-250 VDC/AC, Ex-version
6	Multifunction input cards, incl. terminals Multifunction input card for channel 2, non-Ex Multifunction input card for channel 2, Ex-version
7	Relay card with 2 limit relays, incl. terminals
8	Mounting kit
9	3-pin. terminal for supply voltage

Item No.	Designation
10	4-pin terminals for analog input Analog input terminal, non-Ex (terminals x1, x2, x3, x4 and x5, x6, x7, x8) Analog input terminal, Ex, blue, top (terminals x1, x2, x3, x4) Analog input terminal, Ex, blue, bottom (terminals x5, x6, x7, x8)
11	Terminal for analog output 2 (O25, O26)
12	Terminal for analog output 1 and status output (DI 11, DI12, O15)
13	Terminal for relay output (R12, R11, R13 and R22, R21, R23)
14	Threaded bolt for fixing the housing mounting frame
W/O. No.	Sealing ring for housing/panel (only devices prior to 10/2010)

10.3 Return

The requirements for safe device return can vary depending on the device type and national legislation.

1. Refer to the web page for information:
<http://www.endress.com/support/return-material>
↳ Select the region.
2. Return the device if repairs or a factory calibration are required, or if the wrong device was ordered or delivered.

10.4 Disposal

10.4.1 IT security

Observe the following instructions before disposal:

1. Delete the data
2. Reset the device

10.4.2 Removing the measuring device

1. Switch off the device
2. Carry out the mounting and connection steps from the "Mounting the measuring device" and "Connecting the measuring device" sections in reverse order. Observe the safety instructions.

10.4.3 Disposing of the measuring device



If required by the Directive 2012/19/EU on waste electrical and electronic equipment (WEEE), the product is marked with the depicted symbol in order to minimize the disposal of WEEE as unsorted municipal waste. Do not dispose of products bearing this marking as unsorted municipal waste. Instead, return them to the manufacturer for disposal under the applicable conditions.

11 Accessories

Various accessories are available for the device, and can be ordered with the device or at a later stage from Endress+Hauser. Detailed information on the specific order code is available from your local Endress+Hauser sales organization or on the product page of the Endress+Hauser website: www.endress.com.

11.1 Device-specific accessories

11.1.1 Other

Retrofitting of relays

	Order No.
Relay card incl. terminals	RIA45X-RA

Upgrade to two-channel device

	Order No.
Multifunction input card for channel 2, incl. terminals, non-Ex	RIA45X-IA
Multifunction input card for channel 2, incl. terminals, Ex version	RIA45X-IB

11.2 Communication-specific accessories

Designation
Interface cable
Commubox TXU10 incl. FieldCare Device Setup and DTM Library
Commubox FXA291 incl. FieldCare Device Setup and DTM Library

12 Technical data

12.1 Input

12.1.1 Measured variable

Current, voltage, resistance, resistance thermometer, thermocouples

12.1.2 Measuring ranges

Current:

- 0/4 to 20 mA +10% overrange
- Short-circuit current: max. 150 mA
- Load: 10 Ω

Voltage:

- 0 to 10 V, 2 to 10 V, 0 to 5 V, 0 to 1 V, 1 to 5 V, ± 1 V, ± 10 V, ± 30 V, ± 100 mV
- Max. permitted input voltage:
 - Voltage ≥ 1 V: ± 35 V
 - Voltage < 1 V: ± 12 V
- Input impedance: $> 1\,000$ k Ω

Resistance:

30 to 3 000 Ω

Resistance thermometer:

- Pt100 as per IEC60751, GOST, JIS1604
- Pt500 and Pt1000 as per IEC60751
- Cu100, Cu50, Pt50, Pt46, Cu53 as per GOST
- Ni100, Ni1000 as per DIN 43760

Thermocouple types:

- Typ J, K, T, N, B, S, R as per IEC60584
- Typ U as per DIN 43710
- Typ L as per DIN 43710, GOST
- Typ C, D as per ASTM E998

12.1.3 Number of inputs

One or two universal inputs

12.1.4 Update time

200 ms

12.1.5 Galvanic isolation

Towards all other circuits

12.2 Output

12.2.1 Output signal

One or two analog outputs, galvanically isolated

Current/voltage output

Current output:

- 0/4 to 20 mA
- Overrange up to 22 mA

Voltage:

- 0 to 10 V, 2 to 10 V, 0 to 5 V, 1 to 5 V
- Overrange: up to 11 V, short-circuit proof, $I_{\max} < 25 \text{ mA}$

HART®

HART® signals are not affected

12.2.2 Loop power supply

- Open-circuit voltage: $24 V_{DC}$ (+15% /-5%)
- Hazardous area version: > 14 V at 22 mA
- Non-hazardous area version: > 16 V at 22 mA
- Maximum 30 mA short-circuit-proof and overload-resistant
- Galvanically isolated from system and outputs

12.2.3 Switching output

Open collector for monitoring the device state as well as open circuit and alarm notification. The OC output is closed in the fault-free operating state. In error state, the OC output is opened.

- $I_{\max} = 200 \text{ mA}$
- $U_{\max} = 28 \text{ V}$
- $U_{\text{on}/\max} = 2 \text{ V}$ at 200 mA

Galvanic isolation to all circuits, test voltage 500 V

12.2.4 Relay output

Relay output for limit monitoring

Relay contact	Changeover
Maximum contact load DC	30 V / 3 A (permanent state, without destruction of the input)
Maximum contact load AC	250 V / 3 A (permanent state, without destruction of the input)
Minimum contact load	500 mW (12 V/10 mA)
Galv. isolation towards all other circuits	Test voltage 1 500 V _{AC}
Switching cycles	> 1 million

12.3 Power supply

12.3.1 Terminal assignment

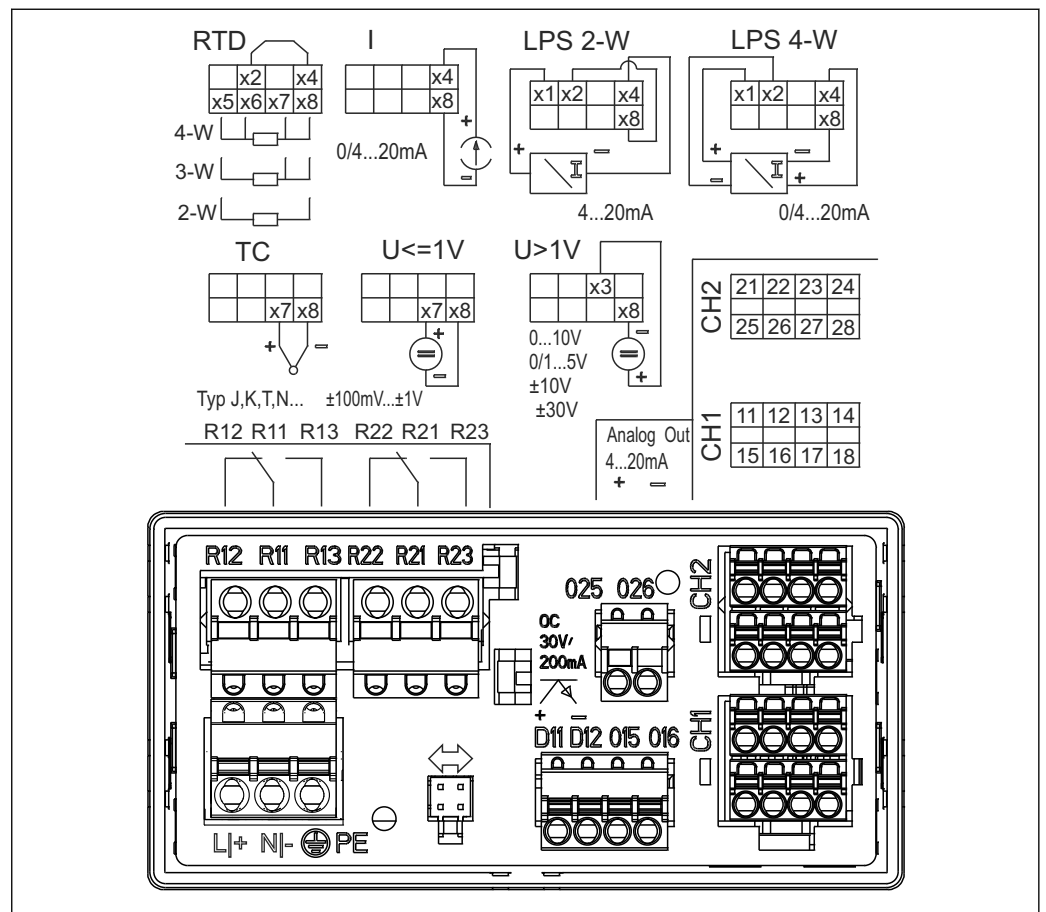

13 Terminal assignment of the process indicator (relay (terminals Rx1-Rx3) and channel 2 (terminals 21-28 and 025/026) optional). Note: Illustrated contact position of the relays if the power supply fails.



12.3.2 Supply voltage

Wide range power supply 24 to 230 V AC/DC (-20 % / +10 %) 50/60 Hz

12.3.3 Power consumption

Max. 21.5 VA / 6.9 W

12.3.4 Interface connection data

Commubox FXA291 PC USB interface

- Connection: 4-pin socket
- Transmission protocol: FieldCare
- Transmission rate: 38,400 baud

Interface cable TXU10-AC PC USB interface

- Connection: 4-pin socket
- Transmission protocol: FieldCare
- Order configuration: interface cable with FieldCare Device Setup DVD incl. all Comm DTMs and Device DTMs

12.4 Performance characteristics

12.4.1 Reference operating conditions

Power supply: 230 V_{AC}, 50/60 Hz

Ambient temperature: 25 °C (77 °F) ± 5 °C (9 °F)

Humidity: 20 %...60 % rel. humidity

12.4.2 Maximum measured error

Universal input:

Accuracy	Input:	Range:	Maximum measured error of measuring range (oMR):
	Current	0 to 20 mA, 0 to 5 mA, 4 to 20 mA; Overrange: up to 22 mA	±0.05%
	Voltage ≥ 1 V	0 to 10 V, 2 to 10 V, 0 to 5 V, 1 to 5 V, 0 to 1 V, ±1 V, ±10 V, ±30 V	±0.1%
	Voltage < 1 V	±100 mV	±0.05%
	Resistance measurement	30 to 3 000 Ω	4-wire: ± (0.10% oMR + 0.8 Ω) 3-wire: ± (0.10% oMR + 1.6 Ω) 2-wire: ± (0.10% oMR + 3 Ω)
	RTD	Pt100, -200 to 850 °C (-328 to 1562 °F) (IEC60751, α=0.00385) Pt100, -200 to 850 °C (-328 to 1562 °F) (JIS1604, w=1.391) Pt100, -200 to 649 °C (-328 to 1200 °F) (GOST, α=0.003916) Pt500, -200 to 850 °C (-328 to 1562 °F) (IEC60751, α=0.00385) Pt1000, -200 to 600 °C (-328 to 1112 °F) (IEC60751, α=0.00385)	4-wire: ± (0.10% oMR + 0.3 K (0.54 °F)) 3-wire: ± (0.10% oMR + 0.8 K (1.44 °F)) 2-wire: ± (0.10% oMR + 1.5 K (2.7 °F))
		Cu100, -200 to 200 °C (-328 to 392 °F) (GOST, w=1.428) Cu50, -200 to 200 °C (-328 to 392 °F) (GOST, w=1.428) Pt50, -200 to 1100 °C (-328 to 2012 °F) (GOST, w=1.391) Pt46, -200 to 850 °C (-328 to 1562 °F) (GOST, w=1.391) Ni100, -60 to 250 °C (-76 to 482 °F) (DIN43760, α=0.00617) Ni1000, -60 to 250 °C (-76 to 482 °F) (DIN43760, α=0.00617)	4-wire: ± (0.10% oMR + 0.3 K (0.54 °F)) 3-wire: ± (0.10% oMR + 0.8 K (1.44 °F)) 2-wire: ± (0.10% oMR + 1.5 K (2.7 °F))
		Cu53, -50 to 200 °C (-58 to 392 °F) (GOST, w=1.426)	4-wire: ± (0.10% oMR + 0.3 K (0.54 °F)) 3-wire: ± (0.10% oMR + 0.8 K (1.44 °F)) 2-wire: ± (0.10% oMR + 1.5 K (2.7 °F))
	Thermocouples	Typ J (Fe-CuNi), -210 to 1200 °C (-346 to 2192 °F) (IEC60584)	± (0.10% oMR + 0.5 K (0.9 °F)) from -100 °C (-148 °F)
		Typ K (NiCr-Ni), -200 to 1372 °C (-328 to 2502 °F) (IEC60584)	± (0.10% oMR + 0.5 K (0.9 °F)) from -130 °C (-202 °F)

Accuracy	Input:	Range:	Maximum measured error of measuring range (oMR):
		Typ T (Cu-CuNi), -270 to 400 °C (-454 to 752 °F) (IEC60584)	± (0.10% oMR + 0.5 K (0.9 °F)) from -200 °C (-328 °F)
		Typ N (NiCrSi-NiSi), -270 to 1 300 °C (-454 to 2 372 °F) (IEC60584)	± (0.10% oMR + 0.5 K (0.9 °F)) from -100 °C (-148 °F)
		Typ L (Fe-CuNi), -200 to 900 °C (-328 to 1 652 °F) (DIN43710, GOST)	± (0.10% oMR + 0.5 K (0.9 °F)) from -100 °C (-148 °F)
		Typ D (W3Re/W25Re), 0 to 2 495 °C (32 to 4 523 °F) (ASTME998)	± (0.15% oMR + 1.5 K (2.7 °F)) from 500 °C (932 °F)
		Typ C (W5Re/W26Re), 0 to 2 320 °C (32 to 4 208 °F) (ASTME998)	± (0.15% oMR + 1.5 K (2.7 °F)) from 500 °C (932 °F)
		Typ B (Pt30Rh-Pt6Rh), 0 to 1 820 °C (32 to 3 308 °F) (IEC60584)	± (0.15% oMR + 1.5 K (2.7 °F)) from 600 °C (1 112 °F)
		Typ S (Pt10Rh-Pt), -50 to 1 768 °C (-58 to 3 214 °F) (IEC60584)	± (0.15% oMR + 3.5 K (6.3 °F)) for -50 to 100 °C (-58 to 212 °F) ± (0.15% oMR + 1.5 K (2.7 °F)) from 100 °C (212 °F)
		Typ U (Cu-CuNi), -200 to 600 °C (-328 to 1 112 °F) (DIN 43710)	± (0.15% oMR + 1.5 K (2.7 °F)) from 100 °C (212 °F)
AD converter resolution		16 bit	
Temperature drift		Temperature drift: ≤ 0.01%/K (0.1%/18 °F) oMR ≤ 0.02%/K (0.2%/18 °F) oMR for Cu100, Cu50, Cu53, Pt50 and Pt46	

Analog output:

Current	0/4 to 20 mA, overrange up to 22 mA	±0.05% of measuring range
	Max. load	500 Ω
	Max. inductivity	10 mH
	Max. capacity	10 μF
	Max. ripple	10 mVpp at 500 Ω, frequency < 50 kHz
Voltage	0 to 10 V, 2 to 10 V 0 to 5 V, 1 to 5 V Overrange: up to 11 V, shortcircuit proof, I _{max} < 25 mA	±0.05% of measuring range ±0.1 % of measuring range
	Max. ripple	10 mVpp at 1 000 Ω, frequency < 50 kHz
Resolution	13 bit	
Temperature drift	≤ 0.01%/K (0.1%/18 °F) of measuring range	
Galvanic isolation	Testing voltage of 500 V towards all other circuits	

12.5 Installation

12.5.1 Mounting location

Panel, cutout 92 x 45 mm (3.62 x 1.77 in) (see 'Mechanical construction').

Max. panel thickness 26 mm (1 in).

12.5.2 Orientation

No restrictions.

The orientation is determined by the readability of the display.

Max. viewing angle range +/- 45° from the central display axis in every direction.

12.6 Environment

12.6.1 Ambient temperature

NOTICE

Operation in the upper temperature range reduces the operating life of the display.

► To avoid heat buildup, always ensure that the device is sufficiently cooled.

Non-Ex/Ex devices: -20 to 60 °C (-4 to 140 °F)

UL devices: -20 to 50 °C (-4 to 122 °F)

12.6.2 Storage temperature

-40 to 85 °C (-40 to 185 °F)

12.6.3 Operating altitude

< 2 000 m (6 560 ft) above MSL

12.6.4 Climate class

To IEC 60654-1, Class B2

12.6.5 Degree of protection

Front IP 65 / NEMA 4 (not UL-assessed)

Device casing/rear IP 20

12.6.6 Electrical safety

Class I equipment, overvoltage category II, pollution degree 2

12.6.7 Condensation

Front: permitted

Device casing: not permitted

12.6.8 Electromagnetic compatibility (EMC)

CE conformity

Electromagnetic compatibility in accordance with all the relevant requirements of the IEC/EN 61326 series and NAMUR Recommendation EMC (NE21). For details refer to the EU Declaration of Conformity.

- Maximum measured error < 1% of measuring range
- Interference immunity according to IEC/EN 61326 series, requirement industrial area
- Interference emission according to IEC/EN 61326 series (CISPR 11) Group 1 Class A

 This unit is not intended for use in residential environments and cannot guarantee adequate protection of the radio reception in such environments.

12.7 Mechanical construction

12.7.1 Design, dimensions

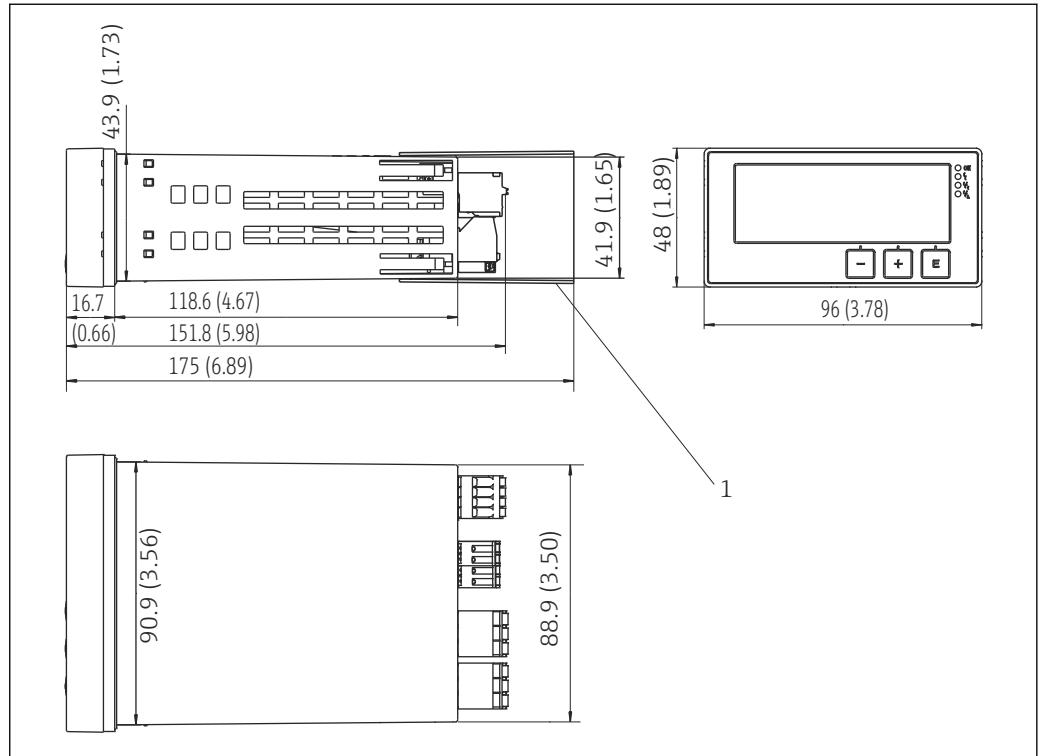

A0010208

14 Dimensions of the panel meter in mm (in)

1 Distance piece for terminals (Ex option)

12.7.2 Weight

Approximately 300 g (10.6 oz)

12.7.3 Material

Housing: plastic PC-GF10

12.7.4 Terminals

Spring terminals	
Relay / auxiliary voltage terminals	0.2 to 2.5 mm ² (24 to 12 AWG)
Input / output terminals	0.2 to 1.5 mm ² (24 to 16 AWG)

12.7.5 Panel thickness

Max. 26 mm (1 in)

12.8 Operability

12.8.1 Local operation

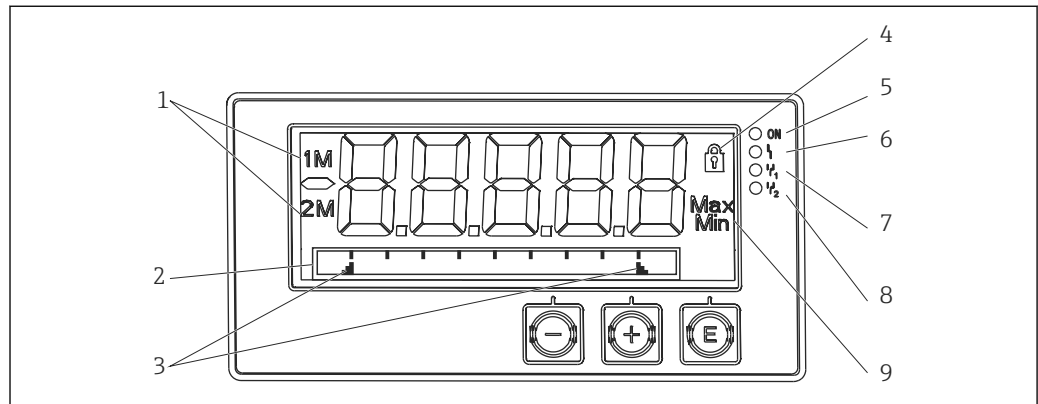

15 Display of the panel meter

- 1 Channel display: 1: analog input 1; 2: analog input 2; 1M: calculated value 1; 2M: calculated value 2
- 2 Dot matrix display for TAG, bar graph and unit
- 3 Limit value indicators in the bar graph
- 4 "Operation locked" indicator
- 5 Green LED; measuring device operational
- 6 Red LED; error/alarm
- 7 Yellow LED; status of relay 1
- 8 Yellow LED; status of relay 2
- 9 Minimum/maximum value indicator

- Display
 - 5-digit, 7-segment backlit LC display
 - Dot matrix for text/bar graph
- Display range
 - 99999 to +99999 for measured values
- Signaling
 - Setup security locking (lock)
 - Measuring range overshoot/undershoot
 - 2 x status relay (only if relay option was selected)

Operating elements

3 keys: -, +, E

12.8.2 Remote operation

Configuration

The device can be configured with the PC software or on site using the operating keys. FieldCare Device Setup is delivered together with the Commubox FXA291 or TXU10-AC (see 'Accessories') or can be downloaded free of charge from www.endress.com.

Interface

4-pin socket for the connection with a PC via Commubox FXA291 or TXU10-AC interface cable (see 'Accessories')

12.9 Accessories

Various accessories are available for the device, and can be ordered with the device or at a later stage from Endress+Hauser. Detailed information on the specific order code is available from your local Endress+Hauser sales organization or on the product page of the Endress+Hauser website: www.endress.com.

12.9.1 Device-specific accessories

Other

Retrofitting of relays

	Order No.
Relay card incl. terminals	RIA45X-RA

Upgrade to two-channel device

	Order No.
Multifunction input card for channel 2, incl. terminals, non-Ex	RIA45X-IA
Multifunction input card for channel 2, incl. terminals, Ex version	RIA45X-IB

12.9.2 Communication-specific accessories

Designation
Interface cable
Commubox TXU10 incl. FieldCare Device Setup and DTM Library
Commubox FXA291 incl. FieldCare Device Setup and DTM Library

13 Appendix

All the parameters available in the configuration menu are listed in the following tables. The values preconfigured at the factory are marked in bold.

13.1 Further explanations regarding the differential pressure application in level measurement

Pressure sensors are connected at both universal inputs. The volume in the CV channels is ultimately calculated with the following calculation steps.

13.1.1 1st calculation step: calculation of the filling level

Both pressure sensors provide the actual pressure at the installation point. A pressure difference (Δp) is determined from both pressures (adjusted by an offset where applicable; this offset must be set in AI1 or AI2). The measured height is calculated by dividing the pressure difference by the density of the medium and multiplying by the gravitational acceleration.

$$\text{Height } h = \Delta p / (\rho * g)$$

The calculation is based on the following units:

- Density ρ [kg/m³]
- Pressure p : [Pa] or [N/m²]

The gravitational acceleration is defined by a constant:

$$\text{Gravitational acceleration } g = 9.81 \text{ m/s}^2$$

NOTICE

Wrong calculation results due to the use of incorrect units

- To obtain a correct calculation, a measured signal (e.g. in mbar) may need to be converted to the correct unit. This is done using a conversion factor. Conversion factors are indicated in the table → 55.

Examples of conversion:

Water: density $\rho = 1000 \text{ kg/m}^3$

Pressure measurement: pressure 1 (bottom): scale 0 to 800 mbar (0 to 80000 Pa);

Present value: 500 mbar (50000 Pa)

Pressure measurement: pressure 2 (head): scale 0 to 800 mbar (0 to 80000 Pa);

Present value: 150 mbar (15000 Pa)

If using Pascal:

$$h = \frac{1}{1000 \text{ kg/m}^3 * 9.81 \text{ m/s}^2} * (50000 - 15000 \text{ Pa}) = 3.57 \text{ m}$$

If using mbar:

$$h = \frac{1}{1000 \text{ kg/m}^3 * 9.81 \text{ m/s}^2} * ((500 - 150 \text{ mbar}) * (1.0000 * 10^2)) = 3.57 \text{ m}$$

$$h = b * \Delta p$$

Calculation of the correction factor b :

$$b = 1 / (\rho * g)$$

$$\text{for water: } b = 1 / (1000 * 9.81) = 0.00010194$$

Tables and examples for the conversion of application-related units into the defined values kg/m³ and Pa and N/m²:

- 1 bar = 0.1 N/mm² = 10⁵ N/m² = 10⁵ Pa
- 1 mbar = 1 hPa = 100 Pa

Conversion factors for various pressure engineering units

	Pascal	Bar	Technical atmosphere	Physical atmosphere	Torr	Pounds per square inch
	[Pa]	[bar]	[at]	[atm]	[torr]	[psi]
	= 1 N/m ²	= 1 Mdyn/cm ²	= 1 kp/cm ²	= 1 pSTP	= 1 mmHg	= 1 lbf/in ²
1 Pa =	1	1.000 · 10 ⁻⁴	1.0197 · 10 ⁻⁵	9.8692 · 10 ⁻⁶	7.5006 · 10 ⁻³	1.4504 · 10 ⁻⁴
1 bar =	1.000 · 10 ⁵	1	1.0197 · 10 ⁰	9.8692 · 10 ⁻¹	7.5006 · 10 ²	1.4504 · 10 ¹
1 mbar =	1.000 · 10 ²	1.000 · 10 ⁻³	1.0197 · 10 ³	9.8692 · 10 ⁻⁴	7.5006 · 10 ⁻¹	1.4504 · 10 ⁻²
1 at =	9.8067 · 10 ⁴	9.8067 · 10 ⁻¹	1	9.6784 · 10 ⁻¹	7.3556 · 10 ²	1.4223 · 10 ¹
1 atm =	1.0133 · 10 ⁵	1.0133 · 10 ⁰	1.0332 · 10 ⁰	1	7.6000 · 10 ²	1.4696 · 10 ¹
1 torr =	1.3332 · 10 ²	1.3332 · 1 ⁻³	1.3595 · 10 ⁻³	1.3158 · 10 ⁻³	1	1.9337 · 10 ⁻²
1 psi =	6.8948 · 10 ³	6.8948 · 1 ⁻³				

Density:

Refer to the specifications of the medium in the tank for the density.

The table below lists standard approximate values, which provide initial orientation.

Medium	Density in [kg/m ³]
Water (at 3.98 °C (39.164 °F))	999.975
Mercury	13 595
Bromine	3 119
Sulfuric acid	1 834
Nitric acid	1 512
Glycerine	1 260
Nitrobenzene	1 220
Deuterium oxide	1 105
Acetic acid	1 049
Milk	1 030
Seawater	1 025
Aniline	1 022
Olive oil	910
Benzene	879
Toluene	872
Essence of turpentine	855
Methylated spirit	830
Diesel fuel	830
Petroleum	800
Methanol	790
Ethanol	789
Gasoline (standardized, average value)	750
Acetone	721

Medium	Density in [kg/m ³]
Carbon disulfide	713
Diethyl ether	713

13.1.2 2nd calculation step: calculation of the volumetric content from the height

The volume can be calculated using the linearization of the calculated height value.

This is done by assigning a certain volume value to every height value, depending on the tank shape.

This linearization is mapped over up to 32 linearization points (support points). However, 2-3 linearization points suffice if the dependency between the filling level and volume is very linear.

The tank linearization module integrated in FieldCare provides support here.

13.2 Display menu

AI1/AI2 Reset minmax

Navigation	 Display → AI1 Reset minmax/AI2 Reset minmax
Description	Resets the saved minimum and maximum values of analog input 1 or analog input 2.
Selection	Yes No
Factory setting	No
Additional information	Only available if "Allow reset = yes" has been configured in the menu Expert → Analog in 1/Analog in 2.

Cv1/Cv2 Reset minmax

Navigation	 Display → Cv1 Reset minmax/Cv2 Reset minmax
Description	Resets the saved minimum and maximum values of math 1 or math 2.
Selection	Yes No
Factory setting	No
Additional information	Only available if "Allow reset = yes" has been configured in the menu Expert → Calc val 1/Calc val 2.

Analog in 1/2

Navigation	 Display → Analog in 1/Analog in 2
Description	Configuration of the display for analog input 1 or analog input 2. If the parameter is set to 'Off', the channel is not displayed.
Selection	Off Unit Bar graph Bar + unit Tag + unit
Factory setting	Tag + unit

 Calc value 1/2

Navigation	☰ Display → Calc value 1/Calc value 1
Description	Configuration of the display for math 1 or math 2. If the parameter is set to 'Off', the channel is not displayed.
Selection	Off Unit Bar graph Bar + unit Tag + unit
Factory setting	Off

 Contrast

Navigation	☰ Display → Contrast
Description	Sets the display contrast
Selection	1...7
Factory setting	6

 Brightness

Navigation	☰ Display → Brightness
Description	Sets the brightness
Selection	1...7
Factory setting	6

 Alternating time

Navigation	☰ Display → Alternating time
Description	Setting for the time for toggling between the displayed channels.
Selection	3 seconds 5 seconds 10 seconds
Factory setting	5 seconds

13.3 Setup menu

 Application

Navigation	☰ Setup → Application
Description	Configuration of the application for the process indicator.
Selection	1-channel 2-channel Diff pressure
Factory setting	1- / 2-channel
Additional information	2-channel is the default setting for two-channel devices, 1-channel for single-channel devices.

 AI1/AI2 Lower range

Navigation	 Setup → AI1 Lower range/AI2 Lower range
Description	Setting for the measuring range lower limit.
User entry	Numerical value ¹⁾
Factory setting	0.0000
Additional information	Only visible if Application → Diff pressure is configured.

 AI1/AI2 Upper range

Navigation	 Setup → AI1 Upper range/AI2 Upper range
Description	Setting for measuring range upper limit.
User entry	Numerical value ¹⁾
Factory setting	100.00
Additional information	Only visible if Application → Diff pressure is configured.

 CV factor

Navigation	 Setup → CV factor
Description	Factor by which the calculated value is multiplied.
User entry	Numerical value ¹⁾
Factory setting	1.0
Additional information	Only visible if Application → Diff pressure is configured.

 CV unit

Navigation	 Setup → CV unit
Description	Unit of the calculated value
Selection	Customized text, max. 5 characters
Additional information	Only visible if Application → Diff pressure is configured.

 CV Bar 0%

Navigation	 Setup → CV Bar 0%
Description	Setting for the 0% value for the bar graph
User entry	Numerical value ¹⁾
Factory setting	0.0000
Additional information	Only visible if Application → Diff pressure is configured.

 CV Bar 100%

Navigation	 Setup → CV Bar 100%
Description	Setting for the 0% value for the bar graph
User entry	Numerical value ¹⁾

Factory setting	100.00
Additional information	Only visible if Application → Diff pressure is configured.

 "Linearization" submenu

Navigation	 Setup → Linearization
Description	Only visible if Application → Diff pressure is configured.

 No lin points

Navigation	 Setup → Linearization → No lin points
Description	Number of linearization points
User entry	2...32
Factory setting	2

 X-value 1...X-value 32

Navigation	 Setup → Linearization → X-value 1...X-value 32
Description	X-value for the linearization point
User entry	Numerical value ¹⁾
Factory setting	0.0000

 Y-value 1...Y-value 32

Navigation	 Setup → Linearization → Y-value 1...Y-value 32
Description	Y-value for the linearization point
User entry	Numerical value ¹⁾
Factory setting	0.0000

 Submenu "Analog in 1"/"Analog in 2"

Navigation	 Setup → Analog in 1/Analog in 2
Additional information	Settings for analog input 1 or analog input 2

 Signal type

Navigation	 Setup → Analog in 1/Analog in 2 → Signal type
Description	Setting for the input type.
Selection	Off Current Voltage RTD TC
Factory setting	Current
Additional information	If the Signal type is set to 'off', all the parameters under it are hidden.

 Signal range

Navigation	☰ Setup → Analog in 1/Analog in 2 → Signal range
Description	Setting for the input signal. The options that are available for selection depend on the "Signal type" that is set.
Selection	4-20mA, 4-20mA squar, 0-20mA, 0-20mA squar 0-10V, 0-10V squar, 0-5V, 2-10V, 1-5V, 1-5V squar, 0-1V, 0-1V squar, +/- 1V, +/- 10V, +/- 30V, +/- 100mV Pt46GOST, Pt50GOST, Pt100IEC, Pt100JIS, Pt100GOST, Pt500IEC, Pt1000IEC, Ni100DIN, Ni1000DIN, Cu50GOST, Cu53GOST, Cu100GOST, 3000 Ohm Type B, Type J, Type K, Type N, Type R, Type S, Type T, Type C, Type D, Type L, Type L GOST, Type U
Factory setting	4-20mA, 0-10V, Pt100IEC, Type J; depending on the selected input signal

 Lower range

Navigation	☰ Setup → Analog in 1/Analog in 2 → Lower range
Description	Setting for the measuring range lower limit.
User entry	Numerical value ¹⁾
Factory setting	0
Additional information	Only visible for "Signal type" = "Current" or "Voltage"

 Upper range

Navigation	☰ Setup → Analog in 1/Analog in 2 → Upper range
Description	Setting for measuring range upper limit.
User entry	Numerical value ¹⁾
Factory setting	100
Additional information	Only visible for "Signal type" = "Current" or "Voltage"

 Connection

Navigation	☰ Setup → Analog in 1/Analog in 2 → Connection
Description	Setting for the connection type for the resistance thermometer.
Selection	2-wire 3-wire 4-wire
Factory setting	2-wire
Additional information	Only visible for "Signal type" = "RTD"

 Tag

Navigation	☰ Setup → Analog in 1/Analog in 2 → Tag
Description	Channel name; TAG is the device designation for channel 1
User entry	Customized text, max. 12 characters

 Unit

Navigation	☰ Setup → Analog in 1/Analog in 2 → Unit
Description	Unit of the channel.
User entry	Customized text, max. 5 characters
Additional information	Only visible for "Signal type" = "Current" or "Voltage"

 Temperature unit

Navigation	☰ Setup → Analog in 1/Analog in 2 → Temperature unit
Description	Setting for the temperature unit.
Selection	°C °F K
Factory setting	°C
Additional information	Only visible for "Signal type" = "RTD" or "TC"

 Offset

Navigation	☰ Setup → Analog in 1/Analog in 2 → Offset
Description	Setting for an offset
User entry	Numerical value ¹⁾
Factory setting	0

 Ref junction

Navigation	☰ Setup → Analog in 1/Analog in 2 → Ref junction
Description	Setting for reference temperature.
Selection	Internal Fixed
Factory setting	Internal
Additional information	Only visible for "Signal type" = "TC"

 Fixed ref junc

Navigation	☰ Setup → Analog in 1/Analog in 2 → Fixed ref junc
Description	Setting for constant reference temperature.
User entry	Numerical value ¹⁾
Additional information	Only visible if "Ref junction" = "Fixed".

 Reset min/max

Navigation	☰ Setup → Analog in 1/Analog in 2 → Reset min/max
-------------------	---

Description	Reset the saved min/max values.
Selection	No Yes
Factory setting	No

 Submenu "Calc value 1"/"Calc value 2"

Navigation	 Setup → Calc value 1/Calc value 2
Additional information	Settings for Math 1 or Math 2

 Calculation

Navigation	 Setup → Calc value 1/Calc value 2 → Calculation
Description	Selection of calculation method.
Selection	Off Sum Difference Average Lineariz. AI1 / Lineariz. AI2 Lineariz. CV1 (only Calc value 2) Multiplication
Factory setting	Off
Additional information	If Calculation is set to 'off', all the parameters under it are hidden.

 Tag

Navigation	 Setup → Calc value 1/Calc value 2 → Tag
Description	Channel name
User entry	Customized text, max. 12 characters

 Unit

Navigation	 Setup → Calc value 1/Calc value 2 → Unit
Description	Unit of the channel
User entry	Customized text, max. 5 characters

 Bar 0%

Navigation	 Setup → Calc value 1/Calc value 2 → Bar 0%
Description	Setting for the 0% value for the bar graph
User entry	Numerical value ¹⁾
Factory setting	0

 Bar 100%

Navigation	 Setup → Calc value 1/Calc value 2 → Bar 100%
-------------------	--

Description	Setting for the 100% value for the bar graph
User entry	Numerical value ¹⁾
Factory setting	100

Factor

Navigation	 Setup → Calc value 1/Calc value 2 → Factor
-------------------	--

Description	Setting for the factor for the calculated value
User entry	Numerical value ¹⁾
Factory setting	1.0

Offset

Navigation	 Setup → Calc value 1/Calc value 2 → Offset
-------------------	--

Description	Setting for an offset
User entry	Numerical value ¹⁾
Factory setting	0

No. lin points

Navigation	 Setup → Calc value 1/Calc value 2 → No. lin points
-------------------	--

Description	Number of linearization points
User entry	2...32
Factory setting	2
Additional information	Only visible if "Calculation" = "Linearization".

X-value

Navigation	 Setup → Calc value 1/Calc value 2 → X-value
-------------------	---

Description	Enter the support points (linearization points) for linearization (max. 32).
User entry	X-value 1...X-value 32, a numerical value in each case ¹⁾
Factory setting	0
Additional information	Only visible if "Calculation" = "Linearization".

Y-value

Navigation	 Setup → Calc value 1/Calc value 2 → Y-value
-------------------	---

Description	Enter the support points (linearization points) for linearization (max. 32).
User entry	Y-value 1...Y-value 32, a numerical value in each case ¹⁾
Factory setting	0
Additional information	Only visible if "Calculation" = "Linearization".

Reset min/max

Navigation	 Setup → Calc value 1/Calc value 2 → Reset min/max
-------------------	---

Description	Reset the saved min/max values.
Selection	No Yes
Factory setting	No

 Submenu "Analog Out 1"/"Analog Out 2"

Navigation	 Setup → Analog Out 1/Analog Out 2
Additional information	Settings for analog output 1 or analog output 2

 Assignment

Navigation	 Setup → Analog Out 1/Analog Out 2 → Assignment
Description	For selecting the source for the output signal
Selection	Off Analog 1 Analog 2 Calc Val 1 Calc Val 2
Factory setting	Off

 Signal type

Navigation	 Setup → Analog Out 1/Analog Out 2 → Signal type
Description	For selecting the signal type for the output signal
Selection	4-20mA 0-20mA 0-10V 2-10V 0-5V 1-5V
Factory setting	4-20mA

 Lower range

Navigation	 Setup → Analog Out 1/Analog Out 2 → Lower range
Description	Setting for the measuring range lower limit
User entry	Numerical value ¹⁾
Factory setting	0

 Upper range

Navigation	 Setup → Analog Out 1/Analog Out 2 → Upper range
Description	Setting for measuring range upper limit
User entry	Numerical value ¹⁾
Factory setting	100

 Submenu "Relay 1"/"Relay 2"

Navigation  Setup → Relay 1/Relay 2

Additional information Settings for relay 1 or relay 2

 Source

Navigation  Setup → Relay 1/Relay 2 → Source

Description For selecting the source for the relay

Selection
 Off
 Analog input 1
 Analog input 2
 Calc value 1
 Calc value 2
 Error

Factory setting Off

 Function

Navigation  Setup → Relay 1/Relay 2 → Function

Description Function of the relay

Selection
 Min
 Max
 Gradient
 Inband
 Outband

Factory setting Min

 Setpoint

Navigation  Setup → Relay 1/Relay 2 → Setpoint

Description Switching threshold for relay

User entry Numerical value¹⁾

Factory setting 0

 Setpoint 2

Navigation  Setup → Relay 1/Relay 2 → Setpoint 2

Description Second switching threshold for relay.

User entry Numerical value¹⁾

Factory setting 0

Additional information Only for the Inband and Outband functions.

 Time base

Navigation  Setup → Relay 1/Relay 2 → Time base

Description	Time base for gradient evaluation in seconds.
User entry	0-60
Factory setting	0
Additional information	Only visible if "Function" = "Gradient".

Hysteresis

Navigation	 Setup → Relay 1/Relay 2 → Hysteresis
Description	Hysteresis for switching threshold(s)
User entry	Numerical value ¹⁾
Factory setting	0



"System" submenu

Navigation	 Setup → System
-------------------	--

Access code

Navigation	 Setup → System → Access code
Description	User code to protect the device configuration.
User entry	0000...9999
Factory setting	0000
Additional information	0000 = protection disabled by user code

Overfill protect

Navigation	 Setup → System → Overfill protect
Description	If the device is used for overfill protection →  33, Overfill protect = yes must be set.
Selection	No Yes
Factory setting	No

Reset

Navigation	 Setup → System → Reset
Description	Reset the device to the as-delivered state
Selection	No Yes
Factory setting	No

1) Numerical values consist of 6 digits, wherein the decimal point counts as a digit, e.g. +99.999

13.4 Diagnostics menu

Current diagn

Navigation  Diagnostics → Current diagn

Description Displays the error code currently active

Last diagn

Navigation  Diagnostics → Last diagn

Description Displays the last error code

Operating time

Navigation  Diagnostics → Operating time

Description Displays the operating hours up until now

Submenu "Diagnost logbook"

Navigation  Diagnostics → Diagnost logbook

Description Displays the last 5 error codes

Diagnostics x

Navigation  Diagnostics → Diagnost logbook → Diagnostics x

Description Displays a message from the Diagnostics logbook.

Submenu "Device information"

Navigation  Diagnostics → Device information

Device tag

Navigation  Diagnostics → Device information → Device tag

Description Display the device name, TAG, channel 1

Serial number

Navigation  Diagnostics → Device information → Serial number

Description Displays the serial number

Order code

Navigation  Diagnostics → Device information → Order code

Description Displays the order code

Order identifier	
Navigation	☰ Diagnostics → Device information → Order identifier
Description	Displays the order code
Firmware version	
Navigation	☰ Diagnostics → Device information → Firmware version
Description	Displays the firmware version
ENP version	
Navigation	☰ Diagnostics → Device information → ENP Version
Description	Displays the ENP version

13.5 Expert menu

In addition to all the parameters from the Setup menu, the following parameters are also available in the Expert Mode.

Direct access	
Navigation	☰ Expert → Direct access
Description	Code to go directly to an operating item
User entry	4-digit code
"System" submenu	
Navigation	☰ Expert → System
Save user setup	
Navigation	☰ Expert → System → Save user setup
Description	Select 'Yes' to save the current device settings. The device can be reset to the saved settings via 'Reset'-'>'User reset'.
Selection	No Yes
Factory setting	No
Submenu "Input"	
Navigation	☰ Expert → Input

 Submenu "Analog in 1"/"Analog in 2"

Navigation	☰ Expert → Input → Analog in 1/Analog in 2
Description	Settings for the analog inputs.
Additional information	The following parameters are available for analog input 1 and for analog input 2.

 Bar 0%

Navigation	☰ Expert → Input → Analog in 1/Analog in 2 → Bar 0%
Description	Setting for the 0% value for the bar graph
User entry	Numerical value ¹⁾
Factory setting	0

 Bar 100%

Navigation	☰ Expert → Input → Analog in 1/Analog in 2 → Bar 100%
Description	Setting for the 100% value for the bar graph
User entry	Numerical value ¹⁾
Factory setting	100

 Decimal places

Navigation	☰ Expert → Input → Analog in 1/Analog in 2 → Decimal places
Description	Setting for the number of decimal places for the display
Selection	XXXXX XXXX.X XXX.XX XX.XXX X.XXXX
Factory setting	XXX.XX

 Damping

Navigation	☰ Expert → Input → Analog in 1/Analog in 2 → Damping
Description	Setting for the damping of the input signal. Enter value in 0.1 s increments from 0.0 s to 999.9 s.
User entry	Numerical value ¹⁾
Factory setting	0.0 for current / voltage 1.0 for temperature inputs

 Failure mode

Navigation	☰ Expert → Input → Analog in 1/Analog in 2 → Failure mode
-------------------	---

Description	Setting for the failure mode.
Selection	Invalid Fixed value
Factory setting	Invalid
Additional information	Invalid: An invalid value is output in the event of an error. Fixed value: A fixed value is output in the event of an error.

 Fixed fail value

Navigation	 Expert → Input → Analog in 1/Analog in 2 → Fixed fail value
Description	The value set here is output in the event of an error.
User entry	Numerical value ¹⁾
Factory setting	0
Additional information	Only visible if Failure mode = Fixed value.

 NAMUR NE 43

Navigation	 Expert → Input → Analog in 1/Analog in 2 → Namur NE 43
Description	Setting whether the failure mode should be according to NAMUR NE 43.
Selection	On Off
Factory setting	On

 Open circ detect

Navigation	 Expert → Input → Analog in 1/Analog in 2 → Open circ detect
Description	Setting for cable open circuit detection.
Selection	On Off
Factory setting	On
Additional information	Only visible if 1-5 V is set for the signal range.

 Failure delay

Navigation	 Expert → Input → Analog in 1/Analog in 2 → Failure delay
Description	Delay time for fault in seconds
User entry	Integer (0-99)
Factory setting	0

 Allow reset

Navigation	 Expert → Input → Analog in 1/Analog in 2 → Allow reset
Description	Setting specifying whether saved min/max values in the Display menu can be reset without entering a (configured) user code.
Selection	No Yes
Factory setting	No

 Submenu "Output"

Navigation  Expert → Output

 Submenu "Analog Out 1"/"Analog Out 2"

Navigation  Expert → Output → Analog Out 1/Analog Out 2

Description Settings for the analog outputs.

Additional information The following parameters are available for analog output 1 and analog output 2.

 Failure mode

Navigation  Expert → Output → Analog Out 1/Analog Out 2 → Failure mode

Description Setting for the failure mode.

Selection
Min
Max
Fixed value

Factory setting Min

Additional information Min: The saved minimum value is output in the event of an error.
Max: The saved maximum value is output in the event of an error.
Fixed value: A fixed value is output in the event of an error.

 Fixed fail value

Navigation  Expert → Output → Analog Out 1/Analog Out 2 → Fixed fail value

Description The value set here is output in the event of an error.

User entry Numerical value¹⁾

Factory setting 0

Additional information Only visible if Failure mode = Fixed value.

 Submenu "Relay 1"/"Relay 2"

Navigation  Expert → Output → Relay 1/Relay 2

Description Settings for the relays.

Additional information The following parameters are available for relay 1 and relay 2.

 Time delay

Navigation  Expert → Output → Relay 1/Relay 2 → Time delay

Description Delay to switch the relay in seconds.

User entry 0-9999

Factory setting 0

 Operating mode

Navigation	 Expert → Output → Relay 1/Relay 2 → Operating mode
Description	Normally closed = NC contact Normally opened = NO contact
Selection	Normally closed Normally opened
Factory setting	Normally closed

Failure mode

Navigation	 Expert → Output → Relay 1/Relay 2 → Failure mode
Description	Normally closed = NC contact Normally opened = NO contact
Selection	Normally closed Normally opened
Factory setting	Normally closed

Submenu "Application"

Navigation	 Expert → Application
-------------------	--

Submenu "Calc value 1"/"Calc value 2"

Navigation	 Expert → Application → Calc value 1/Calc value 2
Description	Settings for the math channels.
Additional information	The following parameters are available for math 1 and math 2.

Decimal places

Navigation	 Expert → Application → Calc value 1/Calc value 2 → Decimal places
Description	Setting for the number of decimal places for the display
Selection	XXXXX XXXX.X XXX.XX XX.XXX X.XXXX
Factory setting	XXX.XX

Failure mode

Navigation	 Expert → Application → Calc value 1/Calc value 2 → Failure mode
Description	Setting for failure mode
Selection	Invalid Fixed value
Factory setting	Invalid

Fixed fail value

Navigation	☰ Expert → Application → Calc value 1/Calc value 2 → Fixed fail value
Description	The value set here is output in the event of an error.
User entry	Numerical value ¹⁾
Factory setting	0
Additional information	Only visible if Failure mode = Fixed value.

Allow reset

Navigation	☰ Expert → Application → Calc value 1/Calc value 2 → Allow reset
Description	Setting specifying whether saved min/max values in the Display menu can be reset without entering a (configured) user code.
Selection	No Yes
Factory setting	No

Submenu "Diagnostics"

Navigation	☰ Expert → Diagnostics
-------------------	------------------------

Verify HW set

Navigation	☰ Expert → Diagnostics → Verify HW set
Description	Verification of the device hardware.
Selection	Yes No
Factory setting	No

Submenu "Simulation"

Navigation	☰ Expert → Simulation
-------------------	-----------------------

Simulation AO1/AO2

Navigation	☰ Expert → Simulation → Simulation AO1/Simulation AO1
Description	Simulation of analog output 1 or analog output 2. The value set in the simulation is output at analog output 1 or analog output 2.
Selection	Off 0mA 3.6mA 4mA 10mA 12mA 20mA 21mA 0V 5 V 10V
Factory setting	Off

Simu relay 1/2

Navigation  Expert → Simulation → Simu relay 1/Simu relay 2

Description Simulation of relay 1 or relay 2.

Selection Off
Closed
Opened

Factory setting Off

1) Numerical values consist of 6 digits, wherein the decimal point counts as a digit, e.g. +99.999

Index

A

Access protection	32
Application conditions	
Configuration	24
Approval guidelines for overfill protection units (ZG-ÜS)	33

C

Cable open circuit detection	37
Configuration	
Access protection	32
Advanced device configuration	32
Analog output	28
Application conditions	24
Calculations	27
Code	32
Differential pressure application	25
Display functions	33
Expert	34
Limit values	28
Overfill protection	33
Relay	28
Setup menu item	26
Universal input	26
Configuration via configuration software	16
Connection	13

D

Delay and hysteresis active	31
Device configuration	
General Information	23
Setup access protection	23
Device reset	38
Diagnosis list	40
Differential pressure application	25
Dimensions	11
Display	18
Display functions	33
Display symbols	18

E

Error codes	40
Expert menu	34

F

Failure mode	37
------------------------	----

H

Hysteresis and delay active	31
---------------------------------------	----

I

Incoming acceptance	9
Installation requirements	11

L

Local operation	16
---------------------------	----

M

Measuring range limits	37
Min/Max memory	37

N

Nameplate	9
---------------------	---

O

Operating elements	16
Operating hours counter	38
Operating matrix	19
Operational safety	7
Overfill protection	33

P

Parameter	
Access code	66
AI1/AI2 Lower range	58
AI1/AI2 Reset minmax	56
AI1/AI2 Upper range	58
Allow reset	70, 73
Alternating time	57
Analog in 1/2	56
Application	57
Assignment	64
Bar 0%	62, 69
Bar 100%	62, 69
Brightness	57
Calc value 1/2	57
Calculation	62
Connection	60
Contrast	57
Current diagn	66
CV Bar 0%	58
CV Bar 100%	58
CV factor	58
CV unit	58
Cv1/Cv2 Reset minmax	56
Damping	69
Decimal places	69, 72
Device tag	67
Diagnostics x	67
Direct access	68
ENP version	68
Factor	63
Failure delay	70
Failure mode	69, 71, 72
Firmware version	68
Fixed fail value	70, 71, 72
Fixed ref junction	61
Function	65
Hysteresis	66
Last diagn	67
Lower range	60, 64
NAMUR NE 43	70
No lin points	59

No. lin points	63
Offset	61, 63
Open circ detect	70
Operating mode	71
Operating time	67
Order code	67
Order identifier	68
Overfill protect	66
Ref junction	61
Reset	66
Reset min/max	61, 63
Save user setup	68
Serial number	67
Setpoint	65
Setpoint 2	65
Signal range	60
Signal type	59, 64
Simu relay 1/2	74
Simulation AO1/AO2	73
Source	65
Tag	60, 62
Temperature unit	61
Time base	65
Time delay	71
Unit	61, 62
Upper range	60, 64
Verify HW set	73
X-value	63
X-value 1...X-value 32	59
Y-value	63
Y-value 1...Y-value 32	59
Post-connection check	15
Product safety	8
Q	
Quick pick keys	36
R	
Relay	
Operating mode	
Gradient	30
InBand	31
Max	29
Min	29
Off	29
OutBand	30
Specification	29
Requirements for personnel	7
Reset	38
Return	43
S	
Saving alarms	38
Saving diagnostic events	38
Saving the setup	32
Self-diagnosis	37
Spare parts	42
Storage	10

Submenu	
Analog in 1/2	59, 69
Analog Out 1/2	64, 71
Application	72
Calc value 1/2	62, 72
Device information	67
Diagnost logbook	67
Diagnostics	73
Input	68
Linearization	59
Output	71
Relay 1/2	65, 71
Simulation	73
System	66, 68
Symbols	18
T	
Transporting	10
W	
Workplace safety	7



71573625

www.addresses.endress.com
