

MDT7000	800 x 480	24-Bit RGB Interface	TFT Module
Specification			
Version: 2		Date: 10/05/2018	
Revision			
1	19/11/2016	First Issue.	
2	10/05/2018	Revised display thickness and FPC placement.	

Display Features			
Display Size	7.0"		
Resolution	800 x 480		
VGA Size	WVGA		
Orientation	Landscape		
Appearance	RGB		
Logic Voltage	3.3V		
Interface	24-Bit RGB		
Brightness	400 cd/m ²		
Touchscreen	N/A		
Module Size	164.90 x 100.00 x 5.70 mm		
Operating Temperature	-20°C ~ +70°C		
Pinout	40 - Way FFC		
		Box Quantity	Weight / Display
		---	---

DESIGN • MANUFACTURE • SUPPLY

Display Accessories	
Part Number	Description
MPBV6	40 Way FFC to cable and wires. Driven by any driver board that can be wired to a 1mm pitch SHDR-40V-S-B receptacle.

Optional Variants	
Appearances	Voltage
Resistive Touch Panel Capacitive Touch Panel	



General Specifications

	Feature	Spec
Characteristics	Size	7 inch
	Resolution	800(horizontal)*480(Vertical)
	Interface	24-bit RGB
	Connect type	Connector
	Color Depth	16.7M
	Technology type	a-Si
	Display Spec. Pixel pitch (mm)	0.192 x 0.1805
	Pixel Configuration	R.G.B. Vertical Stripe
	Display Mode	Normally White
	Driver IC	
	Surface Treatment	HC
	Viewing Direction	12 O'clock
Mechanical	LCM (W x H x D) (mm)	164.9*100*5.7
	Active Area(mm)	154.08 x 85.92
	With /Without TSP	Without TSP
	Weight (g)	TBD
	LED Numbers	27 LEDs

Note 1: Viewing direction is follow the data which measured by optics equipment.

Note 2: Requirements on Environmental Protection: RoHS

Note 3: LCM weight tolerance: +/- 5%

DESIGN • MANUFACTURE • SUPPLY



Input/Output Terminals

No.	Symbol	Description
1	K	Power for LED backlight cathode
2	A	Power for LED backlight anode
3	GND	Ground
4	VDD	Power supply
5~12	R0~R7	Data bus
13~20	G0~G7	Data bus
21~28	B0~B7	Data bus
29	DGND	Ground
30	DOTCLK	Pixel clock
31	DISP	Display on/ off
32	HSYNC	Horizontal sync Signal
33	VSYNC	Vertical sync signal
34	DE	Data Enable
35	NC	No connected
36	GND	System Ground
37	XR(NC)	The right side signal pin of TP
38	YD(NC)	The bottom side signal pin of TP
39	XL(NC)	The left side signal pin of TP
40	YU(NC)	The top side signal pin of TP



Absolute Maximum Ratings

Item	Symbol	MIN	MAX	Unit	Remark
Supply Voltage	V _{CC}	-0.3	6	V	
Operating Temperature	T _{OPR}	-20	70	°C	
Storage Temperature	T _{STG}	-30	80	°C	

Electrical Characteristics

Driving TFT LCD Panel

Parameter	Symbol	Min	Typ	Max	Unit
Supply Voltage	VDD	3.0	3.3	3.6	V
Current of power supply	IVDD	-	4.0	10	mA
Input voltage 'H' level	VIH	0.7VDD	-	VDD	V
Input voltage 'L' level	VIL	0	-	0.3VDD	V

T_a = 25 °C

Interface Timing

Item	Symbol	Min.	Typ.	Max.	Unit	Note
DCLK cycle time	T _{cph}	25			ns	
DCLK frequency	f _{clk}		30	40	MHz	
DCLK pulse duty	T _{cwh}	40	50	60	%	
VSD setup time	T _{vst}	8			ns	
VSD hold time	T _{vhd}	8			ns	
HSD setup time	T _{hst}	8			ns	
HSD hold time	T _{hhd}	8			ns	
Data setup time	T _{dsu}	8			ns	
Data hold time	T _{dhd}	8			ns	
DE setup time	T _{esu}	8			ns	
DE hold time	T _{ehd}	8			ns	
Horizontal display area	thd		800		T _{cph}	
HSD period time	th		928		T _{cph}	
HSD pulse width	thpw	1	48		T _{cph}	
HSD back porch	thb		40		T _{cph}	
HSD front porch	thfp		40		T _{cph}	
Vertical display area	tvd		480		th	
VSD period time	tv		525		th	
VSD pulse width	tvpw		3		th	
VSD back porch	tvb		29		th	
VSD front porch	tvfp		13		th	



Timing Diagram of Interface Signal

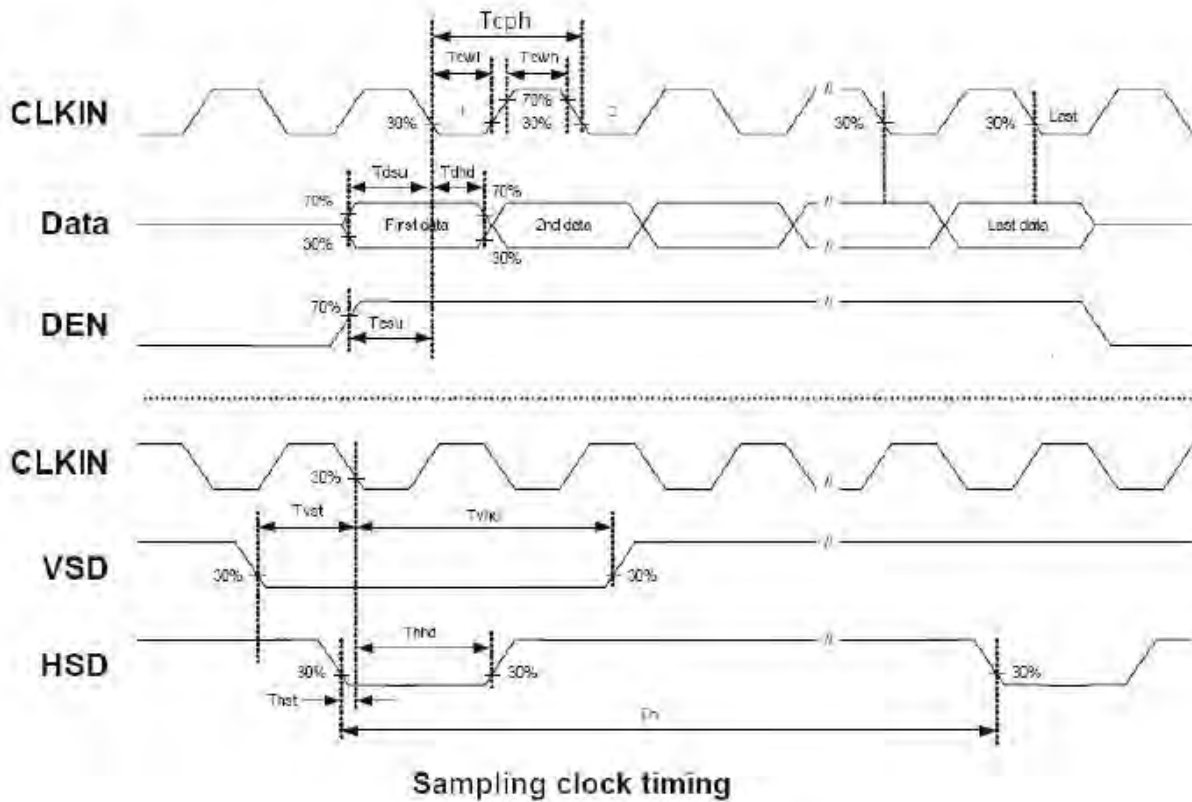

Sampling clock timing

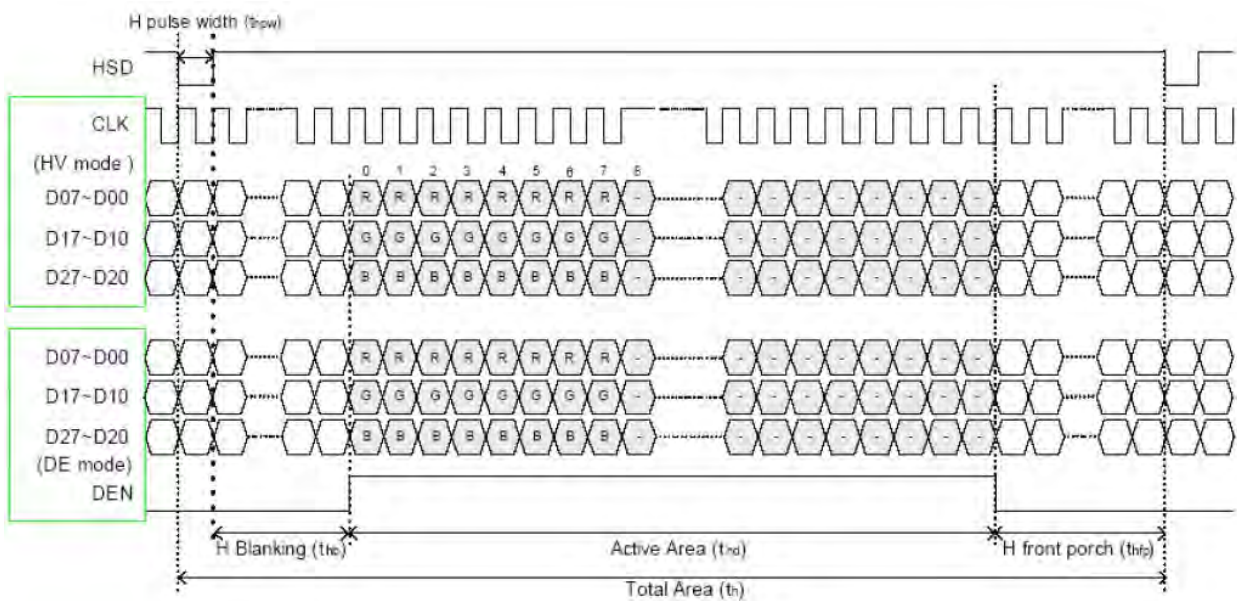

Horizontal display timing range

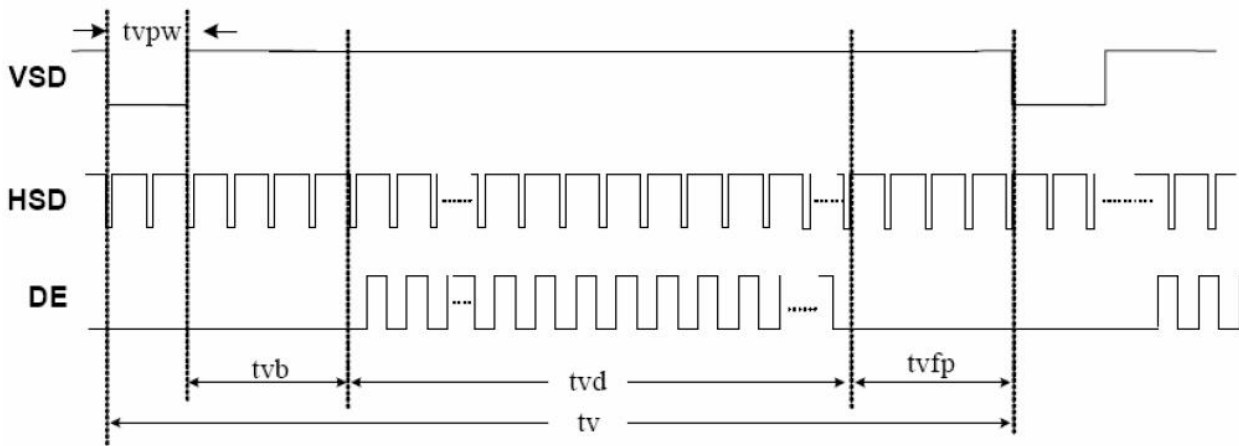

Vertical timing

Driving Backlight

Item	Symbol	MIN	TYP	MAX	Unit	Remark
Forward Current	I_F		160		mA	
Forward Voltage	V_F	9.3	9.6	9.9	V	
Backlight Power consumption	W_{BL}				W	

Note 1: Each LED : $I_F = 20 \text{ mA}$, $V_F = 3.2 \text{ V}$.

Note 2: Optical performance should be evaluated at $T_a = 25^\circ \text{C}$ only.

Note 3: If LED is driven by high current, high ambient temperature & humidity condition. The life time of LED will be reduced. Operating life means brightness goes down to 50% initial brightness. Typical operating life time is estimated data.

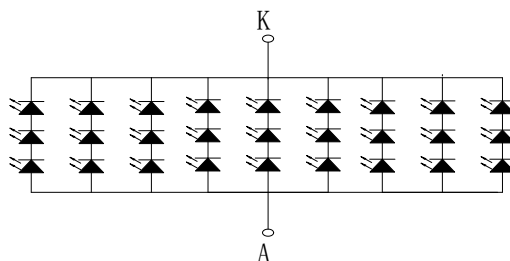

Figure : LED connection of backlight

Optical Characteristics

Items	Symbol	Condition	Min.	Typ.	Max.	Unit	Remark	
Viewing angles	θ_T	Center CR \geq 10		45	-	Degree.	Note2	
	θ_B			65	-			
	θ_L			65	-			
	θ_R			65	-			
Contrast Ratio	CR	$\Theta = 0$	-	400	500	-	Note1, Note3	
Response Time	T _{ON}	25° C	-	5	7	ms	Note1, Note4	
	T _{OFF}		-	20	28			
Chromaticity	White	Backlight is on	X _W	TBD	TBD	TBD	-	Note1, Note5
			Y _W	TBD	TBD	TBD	-	
	Red		X _R	TBD	TBD	TBD	-	
			Y _R	TBD	TBD	TBD	-	
	Green		X _G	TBD	TBD	TBD	-	
			Y _G	TBD	TBD	TBD	-	
	Blue		X _B	TBD	TBD	TBD	-	
			Y _B	TBD	TBD	TBD	-	
Uniformity	U		-	70	-	%	Note1, Note6	
Luminance	L		300	400			Note1, Note7	

Test Conditions:

1. IF= 20mA(one channel),the ambient temperature is 25.
2. The test systems refer to Note 1 and Note 2.

Note 1:Definition of optical measurement system.

The optical characteristics should be measured in dark room. After 5 minutes operation, the optical properties are measured at the center point of the LCD screen. All input terminals LCD panel must be ground when measuring the center area of the panel.



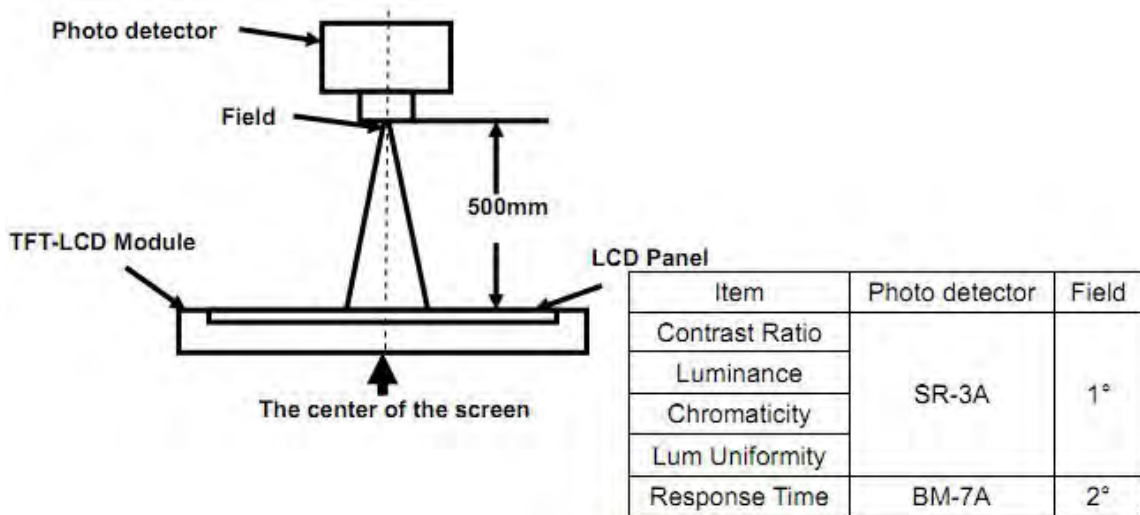

Note 2: Definition of viewing angle range and measurement system.
 viewing angle is measured at the center point of the LCD by CONOSCOPE(ergo-80).

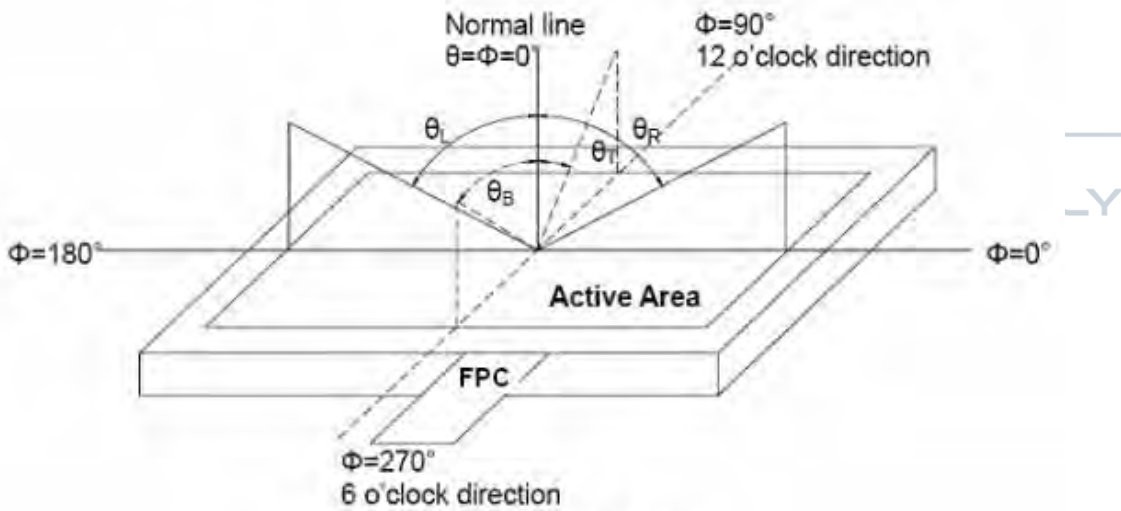

Fig. 1 Definition of viewing angle

Note 3: Definition of contrast ratio

$$\text{Contrast ratio (CR)} = \frac{\text{Luminance measured when LCD is on the "White" state}}{\text{Luminance measured when LCD is on the "Black" state}}$$



Note 4: Definition of Response time

The response time is defined as the LCD optical switching time interval between “White” state and “Black” state. Rise time (TON) is the time between photo detector output intensity changed from 90% to 10%. And fall time (TOFF) is the time between photo detector output intensity changed from 10% to 90%.

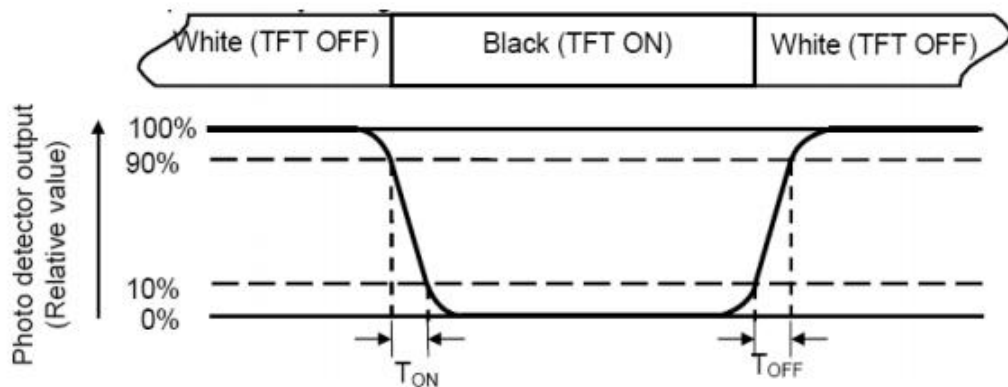

Note 5: Definition of color chromaticity (CIE1931)

Color coordinates measured at center point of LCD.

Note 6: Definition of Luminance Uniformity

Active area is divided into 9 measuring areas (Refer Fig. 2). Every measuring point is placed at the center of each measuring area.

$$\text{Luminance Uniformity}(U) = L_{\min} / L_{\max}$$

L-----Active area length W----- Active area width

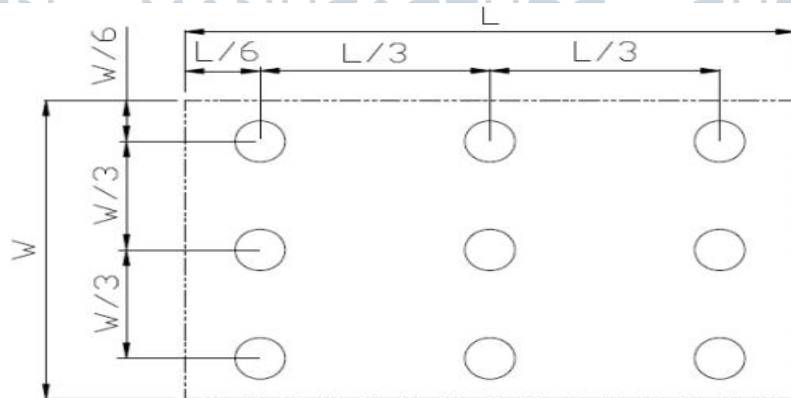

Fig. 2 Definition of uniformity

Lmax: The measured maximum luminance of all measurement position.

Lmin: The measured minimum luminance of all measurement position.

Note 7: Definition of Luminance :

Measure the luminance of white state at center point.



Environmental / Reliability Tests

No	Test Item	Condition	Remarks
1	High Temperature Opeartion	Ts= +70°C, 240hrs	Note 1 IEC60068-2-2, GB2423. 2-89
2	Low Temperature Opeartion	Ta= -20°C, 240hrs	Note 2 IEC60068-2-1 GB2423.1-89
3	High Temperature Storage	Ta= +80°C, 240hrs	IEC60068-2-2 GB2423. 2-89
4	Low Temperature Storage	Ta= -30°C, 240hrs	IEC60068-2-1 GB/T2423.1-89
5	High Temperature & Humidity Storage	Ta= +60°C, 90% RH max, 160 hours	IEC60068-2-3 GB/T2423.3-2006
6	Thermal Shock (Non-operation)	-30°C 30 min ~ +80°C 30 min Change time: 5min, 30 Cycle	Start with cold temperature,end with high temperature IEC60068-2-14, GB2423.22-87
7	Electro Static Discharge (Opeartion)	C=150pF, R=330 Ω, 5 points/panel Air: ±8KV, 5 times; Contact: ±4KV, 5 times; (Environment: 15°C ~ 35°C, 30% ~ 60%, 86Kpa ~ 106Kpa)	IEC61000-4-2 GB/T17626.2-1998
8	Vibration (Non-operation)	Frequency range: 10~55Hz, Stroke: 1.mm Sweep: 10Hz~55Hz~10Hz 2 hours for each direction of X .Y. Z. (package condition)	IEC60068-2-6 GB/T2423.5-1995
9	Shock (Non-operation)	60G 6ms, ± X, ± Y, ± Z 3 times for each direction	IEC60068-2-27 GB/T2423.5-1995
10	Package Drop Test	Height: 80 cm, 1 corner, 3 edges, 6 surfaces	IEC60068-2-32 GB/T2423.8-1995

Note: 1. Ts is the temperature of panel's surface.

2. Ta is the ambient temperature of sample.



Mechanical Drawing

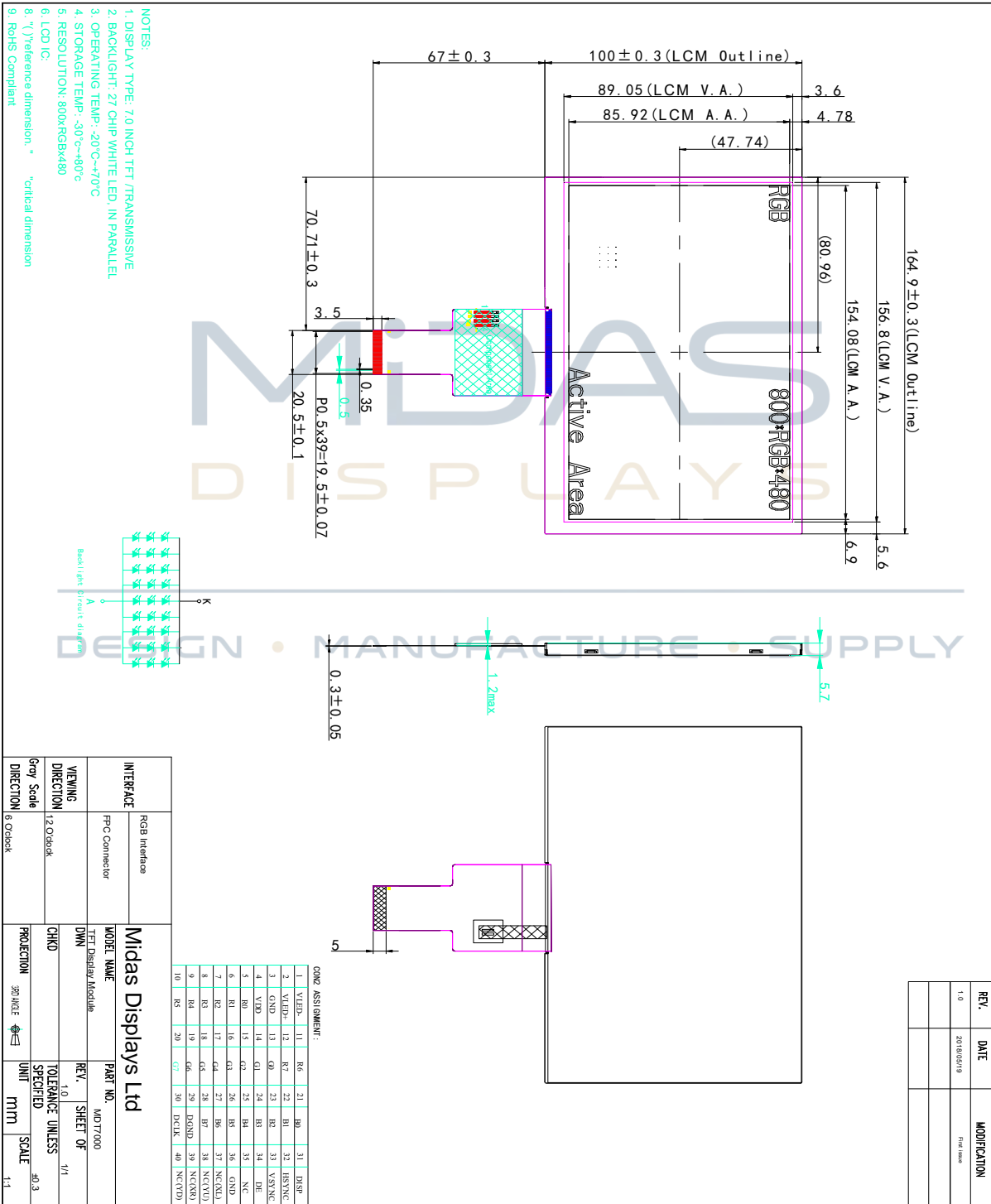

Precautions For Use of LCD modules

1 Handling Precautions

1.1. The display panel is made of glass. Do not subject it to a mechanical shock by dropping it from a high place, etc.

1.2. If the display panel is damaged and the liquid crystal substance inside it leaks out, be sure not to get any in your mouth, if the substance comes into contact with your skin or clothes, promptly wash it off using soap and water.

1.3. Do not apply excessive force to the display surface or the adjoining areas since this may cause the color tone to vary.

1.4. The polarizer covering the display surface of the LCD module is soft and easily scratched. Handle this polarizer carefully.

1.5. If the display surface is contaminated, breathe on the surface and gently wipe it with a soft dry cloth. If still not completely clear, moisten cloth with one of the following solvents:

- Isopropyl alcohol
- Ethyl alcohol

Solvents other than those mentioned above may damage the polarizer. Especially, do not use the following:

- Water
- Ketone
- Aromatic solvents

1.6. Do not attempt to disassemble the LCD Module.

1.7. If the logic circuit power is off, do not apply the input signals.

1.8. To prevent destruction of the elements by static electricity, be careful to maintain an optimum work environment.

1.8.1. Be sure to ground the body when handling the LCD Modules.

1.8.2. Tools required for assembly, such as soldering irons, must be properly ground.

1.8.3. To reduce the amount of static electricity generated, do not conduct assembly and other work under dry conditions.

1.8.4. The LCD Module is coated with a film to protect the display surface. Be care when peeling off this protective film since static electricity may be generated.

2 Storage Precautions

2.1. When storing the LCD modules, avoid exposure to direct sunlight or to the light of fluorescent lamps.

2.2. The LCD modules should be stored under the storage temperature range. If the LCD modules will be stored for a long time, the recommend condition is:

Temperature : 0°C ~ 40°C Relatively humidity: ≤80%

2.3. The LCD modules should be stored in the room without acid, alkali and harmful gas.

3 Transportation Precautions

The LCD modules should be no falling and violent shocking during transportation, and also should avoid excessive press, water, damp and sunshine.

