

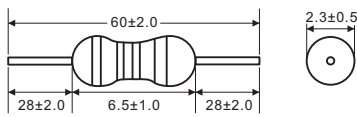

## 280pcs 3mm Standard LED assortment with LED mount and pre-resistor Item No.: 1801O003

This range of experiments and practitioners with superbright standard LEDs with a diameter of 3 mm and various series resistors is ideal for immediate start in experiments with semiconductor light. Through resistor combinations of parallel or series connection or varying the supply voltage, different operating currents (brightnesses) can be realized. Addition LED mounting clips for easy mount and installation onto casing or panel. A brief description of the components contained is clearly printed on the inside of the lid.



### Carbon Film Fixed Resistor

Color	1st digit	2nd digit	multiply	tolerance
Black	0	0	1Ω	
Brown	1	1	10Ω	1%
Red	2	2	100Ω	2%
Orange	3	3	1KΩ	
Yellow	4	4	10KΩ	
Green	5	5	100KΩ	0.50%
Blue	6	6	1MΩ	0.25%
Violet	7	7	10MΩ	0.10%
Grey	8	8		0.05%
White	9	9		
Gold				5%
Silver				10%

Resistance - 220Ω, 470Ω, 680Ω, 1KΩ  
 Rated Power - 0.25W  
 Maximum Working Voltage - 250V  
 Maximum Overload Voltage - 500V  
 Dielectric Withstanding Voltage - 350V

### LED Mounting Clips

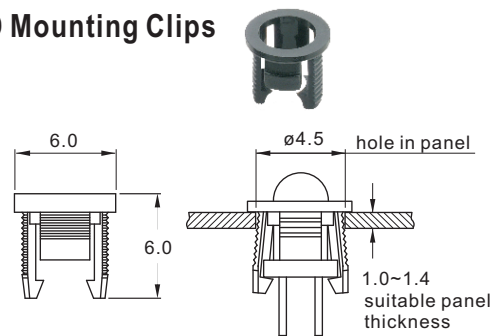

Material: PA66, 94V-2  
 Color: Black  
 Operating Temperature: -10~75°C

### ø 3 mm LED Diode

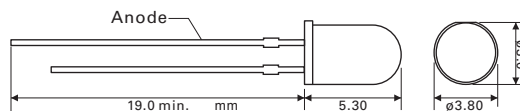

Light Source	Red	Blue	Green	Yellow	Cold White	Warm White
Lens color	Diffuse	Diffuse	Diffuse	Diffuse	Water clear	Water clear
Chip material	Gap	InGaAlP	InGaAlP	Gap	InGaAlP	InGaAlP
Wavelength / color temperature	625-635nm	460-465nm	568-572nm	587-590nm	8000-9000K	3000-3200K
Max. Luminous intensity	600 mcd	1500 mcd	100 mcd	600 mcd	8000 mcd	9000 mcd
Viewing angle (typ.)	30°	30°	30°	30°	30°	25°
Forward current (max.)	20 mA	20 mA	20 mA	20 mA	20 mA	20 mA
Forward voltage (typ.)	2.0 V	3.0 V	2.0 V	2.0 V	3.0 V	3.0 V
Operating temperature	-25°C - 80°C					
Storage temperature	-30°C - 100°C					