

F4

Snap-action Microswitches

Ultraminiature



F4



Characteristics	<ul style="list-style-type: none"> ■ small size ■ long mechanical and electrical life ■ solder ■ 2 mm faston ■ PCB terminals
Rating	250 VAC, 5 A
Dimensions (mm)	12.8 × 10 × 5
Actuator	<ul style="list-style-type: none"> ■ Plunger ■ plain lever ■ simulated roller lever/cam follower
Approvals	UL, CSA

Preferred Range

Ordering Reference	Actuating Force (N) (ozf)		Sealing	Operating pos. (mm) (in)		Terminal	Circuit	Actuator	Contacts	Electrical rating
F4T7UL	1.4	5.00	IP40	8.1	0.32	Solder	C0	Plunger	Ag	Up to 250 VAC, 5 A
F4T7GPUL	1.4	5.00	IP40	8.1	0.32	Solder	C0	Plunger	Gold plate	Up to 250 VAC, 5 A
F4T7Y1UL	0.6	2.20	IP40	8.2	0.32	Solder	C0	Plain lever	Ag	Up to 250 VAC, 5 A
F4T7Y1GPUL	0.6	2.20	IP40	8.2	0.32	Solder	C0	Plain lever	Gold plate	Up to 250 VAC, 5 A
F4T7YCUL	0.7	2.50	IP40	10.3	0.41	Solder	C0	Simulated roller	Ag	Up to 250 VAC, 5 A
F4T7YCGPUL	0.7	2.50	IP40	10.3	0.41	Solder	C0	Simulated roller	Gold plate	Up to 250 VAC, 5 A

Specifications

Housing	Glass fibre reinforced nylon
Plunger	Nylon
Mechanism	Snap-action, single pole
Functions	Change-over, Normally open, Normally closed
Contacts	Fixed, Moving – Ag or Gold plate on Ag
Terminals	2.0 mm (0.08 in) faston and solder - brass, gold flashed
Temperature range °C	-40°C to +85°C
Mechanical life	10 ⁷ cycles minimum (impact free actuation)
Protection	IP 40 (enclosure)
Mounting	Side mounting
Actuators	Plain lever; simulated roller (cam follower) lever
Accessories	Lug mounting frame, insulating sheet, spring-leaf actuator

Circuit diagram

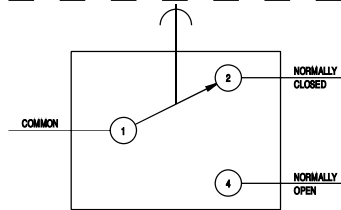

Dimensions

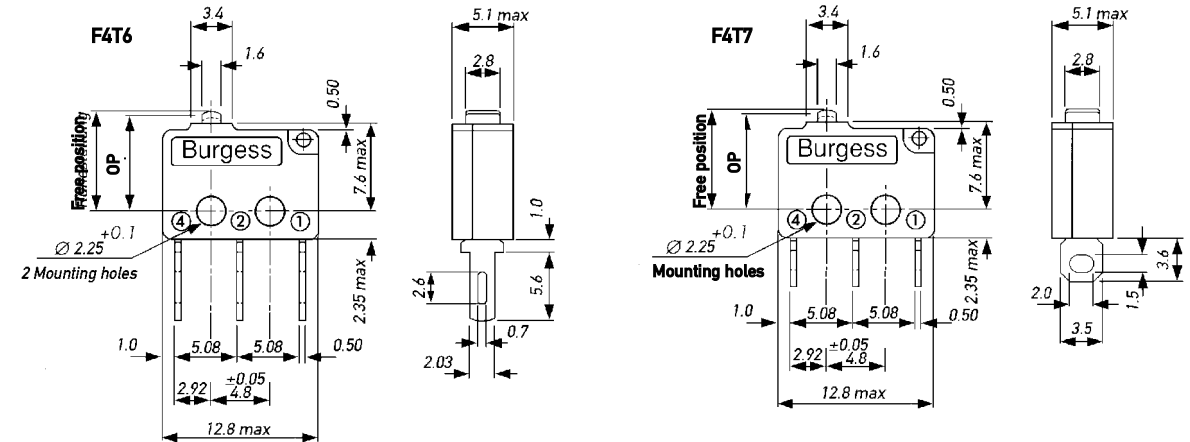

Recommended maximum electrical ratings

Voltage (max)	Load (A)	Approval
250 VAC	5 (0.75 pf)	UL 1054/CSA 22.2 No. 55 - 6,000 operations
125 VAC	5 (0.75 pf)	UL 1054/CSA 22.2 No. 55 - 6,000 operations
0 - 15 VDC	5	General rating - 50,000 operations
15 - 30 VDC	3	General rating - 50,000 operations

F4

Operating Characteristics

Actuator	Reference	Actuating Force		Release Force		Free Position		Operating Position		Movement Differential		Over travel		
		Maximum (N)	(ozf)	Minimum (N)	(ozf)	Maximum (mm)	(in)	(mm)	(in)	Maximum (mm)	(in)			
Plunger	F4T6	1,4	5,00	0,25	0,90	8,8	0,35	8,1	+0,3 -0,2	0,32	+0,01 -0,008	0,13	0,005	*
	F4T7													
Y1-Lever	F4T6Y1	0,6	2,20	0,07	0,25	10,0	0,39	8,2	+1,0 -0,7	0,32	+0,04 -0,03	0,70	0,030	*
	F4T7Y1													
Width of lever 3.0 mm/0.12 in														
YC-Lever	F4T6YC	0,7	2,50	0,09	0,32	11,7	0,46	10,3	+0,8 -0,55	0,41	+0,03 -0,02	0,45	0,020	*
	F4T7YC													
Width of lever 3.0 mm/0.12 in														

Operating characteristics are specified from the mounting holes.

* Plunger can be depressed flush with housing. The housing should not be used as an end stop.

Type coding key for standard products

Basic type	F4	Example: F4 T6 C2 Y1 GP UL											
Terminals	T6	Faston	2.03 × 0.5 × 6.6 long										
	T7	Solder	3.50 × 0.5 × 3.6 long										
	T8	PCB	0.8 × 0.5 × 4.0 long										
Circuit	No symbol, change-over												
	C2	Normally closed											
	C4	Normally open											
Actuators	No symbol, without lever												
	Y1	Plain lever 21.0 mm											
	YC	Cam follower lever 16.9 mm											
Contacts Material	No symbol, Ag												
	GP	Gold plate on Ag (GP)											
Approvals	No symbol, without approval												
	UL	UL and CSA approval											
Special Features	/ □ □ □ □	Saia-Burgess specialise in customer specific solutions. Additional product variants are available or can be provided. If your requirements cannot be satisfied from the options listed, please contact www.saia-burgess.com or your local SB outlet.											