

TOP VIEW

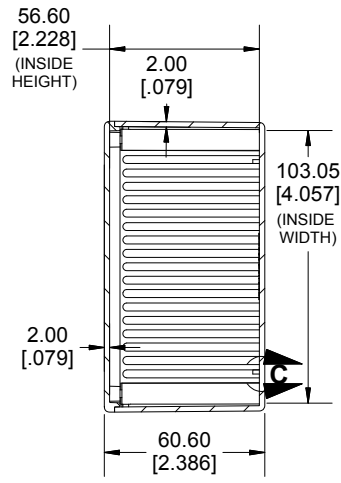

SECTION A-A

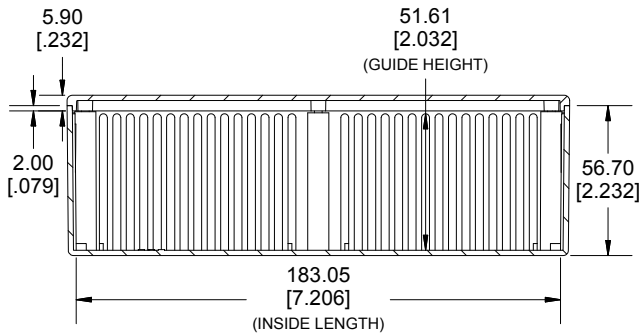
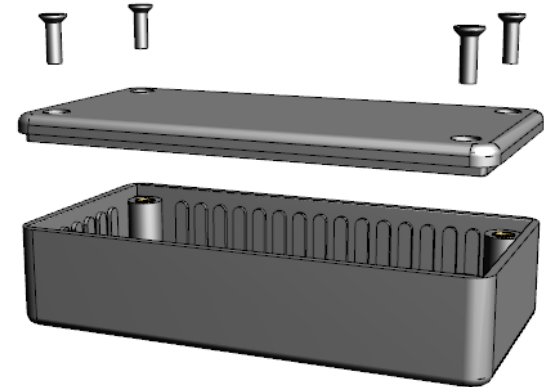

**SECTION B-B
SIDE VIEW**

DETAIL C

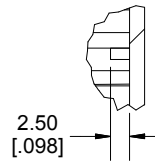

DETAIL D

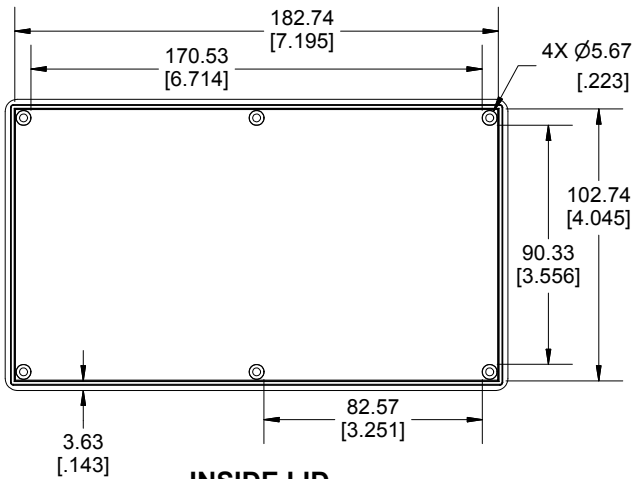
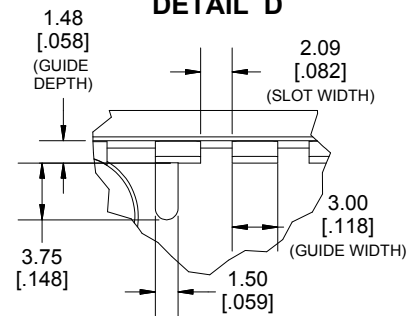

INSIDE LID

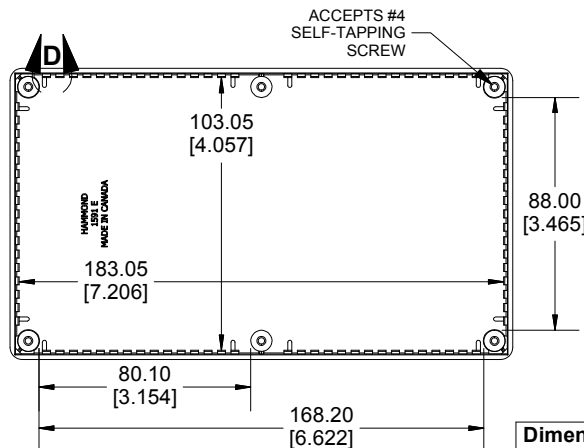

INSIDE BOX

Enclosures can be Factory Modified (Milling, Drilling, Printing etc.)
Contact Factory mjm@hammondmfg.com for quotes
Solid models of this enclosure available in STEP or IGES.

NOTE	
Purchased assembly includes box, lid and 6 cover screws Enclosure made from GPABS.	
Recommended Torque: 42-57 ozf.in (30-40 cN.m)	
PART NUMBERS	
1591E Enclosure	
General Purpose ABS Black	1591ESBK
General Purpose ABS Grey	1591ESGY
Accessories	
Plated Cover screw	1591TS100 (Silver)
#4 X 1/2" (100Pkg) Self-Tapping	1591TS100BK (Black)
PC Board Card Adapters	1591Z6 (6Pkg)
	1591Z50 (50 Pkg)
	1591Z100 (100Pkg)
Nylon Belt / Pocket clip	1599CLIP (Black)
	1599CLIPGY (Grey)
Clear Lids - Flame Retardant Polycarbonate - Lid ONLY	1591EC

**HAMMOND
MANUFACTURING®**

1591ES

www.hammondmfg.com

Dimensions:
mm
[inches]