

DI521A

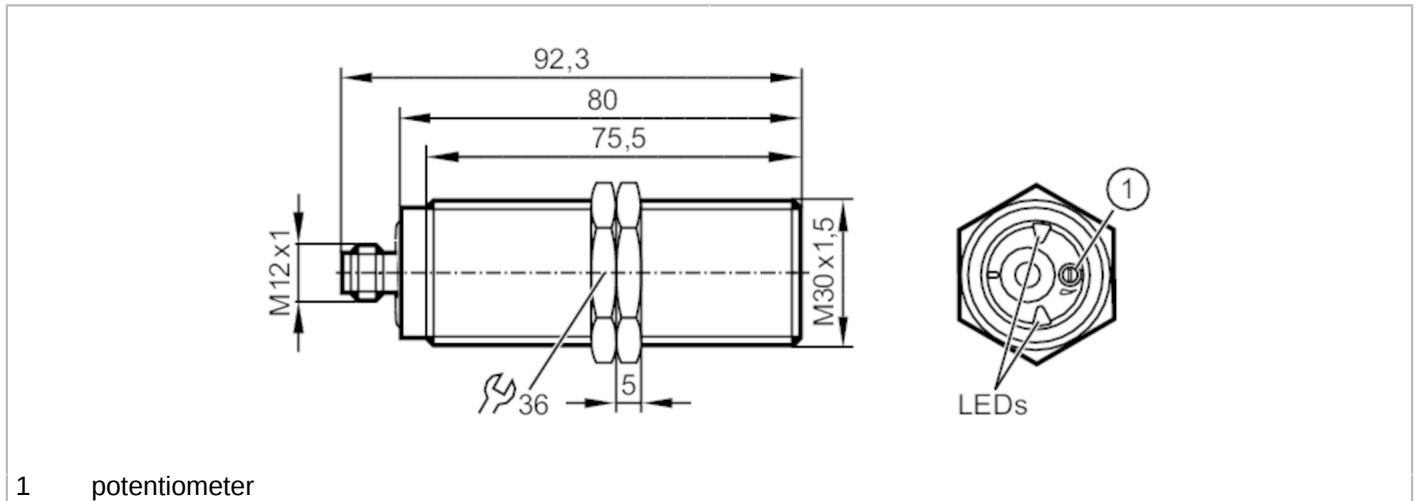

Compact evaluation unit for speed monitoring

DIA3010-ZPKG/US/3D



1 potentiometer





Product characteristics		
Electrical design		PNP
Output function		normally open
Sensing range	[mm]	10
Dimensions	[mm]	M30 x 1.5 / L = 92.3
Application		
Application	simple evaluation of rotating and linear movement with regard to underspeed; blocking	
Electrical data		
Nominal voltage DC	[V]	10...36
Current consumption	[mA]	< 20
Protection class		III
Reverse polarity protection		yes
Outputs		
Total number of outputs		1
Electrical design		PNP
Output function		normally open
Max. voltage drop switching output DC	[V]	2.5
Permanent current rating of switching output DC	[mA]	250
Short-time current rating of switching output	[mA]	250
Short-circuit proof		yes
Overload protection		yes
Detection zone		
Sensing range	[mm]	10
Sensing range adjustable		no
Operating distance	[mm]	0...8.1
Measuring/setting range		
Setting range	[Imp/min]	5...3600

DI521A



Compact evaluation unit for speed monitoring

DIA3010-ZPKG/US/3D

Accuracy / deviations		
Correction factor	steel: 1 / stainless steel: 0.7 / brass: 0.5 / aluminium: 0.4 / copper: 0.3	
Hysteresis [% of Sr]	10	
Response times		
Start-up delay [s]	15	
Max. damping frequency [Imp/min]	18000	
Software / programming		
Adjustment of the switch point	multiturn potentiometer	
Operating conditions		
Ambient temperature [°C]	-25...60	
Storage temperature [°C]	-25...60	
Protection	IP 65; IP 67	
Tests / approvals		
ATEX marking	 II 3D Ex tc IIIC T80°C Dc X	
EMC	EN 60947-5-2	
Shock resistance	DIN EN 60947-5-2	
Vibration resistance	DIN EN 60947-5-2	
MTTF [years]	3262	
Mechanical data		
Weight [g]	267.2	
Mounting	flush mountable	
Dimensions [mm]	M30 x 1.5 / L = 92.3	
Thread designation	M30 x 1.5	
Materials	brass special coating; PA; stainless steel; TPE-U	
Displays / operating elements		
Display	switching status	1 x LED, green
	input signal	1 x LED, yellow
Accessories		
Accessories (supplied)	lock nuts: 2	
Electrical connection		
Connector: 1 x M12		
		

DI521A



Compact evaluation unit for speed monitoring

DIA3010-ZPKG/US/3D

Connection

