

HOUSINGS

NUMBER OF CIRCUITS	PLUG PART NUMBER		CAP PART NUMBER		TWISTLOK CAP PART NUMBER	
	NATURAL ¹	WHITE ²	NATURAL ¹	WHITE ²	NATURAL ¹	WHITE ²
1	350867	350865	770421	350866	—	—
2●	480698	350777	480699	350778	—	—
3●	480700	350766	480701	350767	—	—
4●	480702	350779	480703	350780	—	—
5●	480763	350809	480764	350810	—	—
6●	640585	640581	926307	926307	—	—
6	480704	350715	480705	350781	794714	794760
8●	640586	640582	926308	926308	—	—
9	480706	350720	480707	350782	794715	794761
10●	926302	926302	926309	926309	—	—
12	480708	350735	480709	350783	794716	794762
15	480710	350736	480711	350784	—	—

1 Natural colored housings are 94V-2 nylon material.
 2 White colored housings are flame-retardant 94V-0 nylon material.
 ● In-line version

Figure 1

1. INTRODUCTION

This instruction sheet provides assembly procedures for the AMP* Universal MATE-N-LOK housings and printed circuit (pc) board headers listed in Figures 1, 2, and 3.

NOTE

Dimensions on this sheet are in metric units [with U.S. customary units in brackets].

Reasons for reissue are provided in Section 8, REVISION SUMMARY.

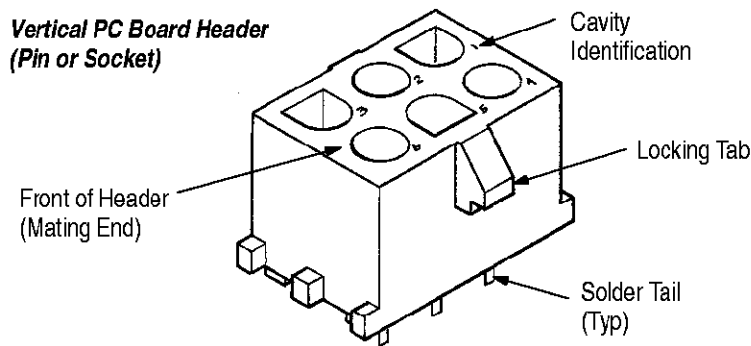

VERTICAL PC BOARD HEADERS

NUMBER OF CIRCUITS	HEADER COLOR ¹	PIN HEADER PART NUMBER ²			SOCKET HEADER PART NUMBER ²		
		STD TAIL ³	STD TAIL PLZD ³	LONG TAIL ⁴	STD TAIL ³	STD TAIL PLZD ³	LONG TAIL ⁴
2●	NATURAL	350428	641963	350582	350759	643411	350986
2●	WHITE	350786	641964	350787	350824	643412	350831
3●	NATURAL	350429	641965	350583	350760	643413	350987
3●	WHITE	350789	641966	350790	350825	643414	350832
4●	NATURAL	350430	641967	350584	350761	643415	350988
4●	WHITE	350792	641968	350793	350826	643416	350833
5●	NATURAL	640466	643405	—	640467	—	—
5●	WHITE	640900	643406	—	640901	—	—
6●	NATURAL	641832	643407	—	—	—	—
6●	WHITE	641831	643408	—	770262	—	—
6	NATURAL	350431	—	350585	350762	643423	350989
6	WHITE	350711	641970	350732	350827	643424	350834
8●	NATURAL	641825	—	770143	—	—	—
8●	WHITE	641828	643410	—	—	—	—
9	NATURAL	350432	641971	350586	350763	643425	350990
9	WHITE	350712	641972	350742	350828	643426	350835
12	NATURAL	350433	641973	350587	350764	—	350991
12	WHITE	350713	641974	350737	350829	643428	350836
15	NATURAL	350434	641975	350588	350765	643429	350992
15	WHITE	350714	641976	350738	350830	643430	350837

1 Natural colored housings are 94V-2 nylon material. White colored housings are flame-retardant 94V-0 nylon material.
 2 Base numbers shown. Dash numbers indicate contacts with a pre-tin finish or a duplex finish.
 3 Use standard tail (and standard tail polarized) for 1.57 [.062] thick pc board.
 4 Use long tail for 3.18 [.125] thick pc board.
 ● In-line version.

Figure 2

2. DESCRIPTION

A connector consists of either (1) a housing (plug or cap) with a specified number of crimp contacts (pin or socket); or (2) a pc board header preloaded with solder tail contacts (pin or socket).

Mating connectors may be a plug and a cap, or a plug and a pc board header, so long as both connectors have an identical number of circuits with a pin contact mating with a socket contact. Mating connectors are

fully polarized for proper engagement and employ a positive locking feature to prevent accidental disengagement.

The plug and cap housings are available with 1 through 15 circuits and accept pin and socket crimp contacts and programmable socket contacts (see Figure 5). Both the plug and the cap housings have individually numbered cavity identification on the BACK (wire end), plus an identification rib on the SIDE indicating the Number 1 cavity.

The housings feature polarizing cavities on the mating end. The plug housing has two locking latches and the cap housing has two locking tabs. The housings are designed for free hanging or panel mounting applications (refer to Section 5, PANEL CUTOUT).

The pc board headers are supplied preloaded with solder tail pin contacts or solder tail socket contacts. Vertical pin and socket headers are available in 2 through 15 circuits. Vertical headers are designed for either 1.57 mm [.062 in.] thick pc boards (standard solder tail length), or 3.18 mm [.125 in.] thick pc boards (long solder tail length). Right-angle pin and socket headers are available in 2 through 8 circuits. All headers feature individually numbered cavity identification on the FRONT (mating end), polarizing cavities, and locking tabs. Refer to Section 6, PRINTED CIRCUIT BOARD LAYOUT.

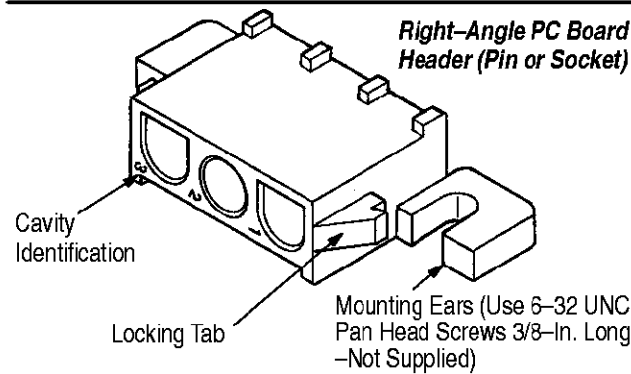

RIGHT-ANGLE PC BOARD HEADERS ¹		
NUMBER OF CIRCUITS	PIN HEADER PART NUMBER ²	SOCKET HEADER PART NUMBER ²
2	350942	643226
3	350943	643228
4	350944	643230
5	350945	643232
6	640583	643234
8	640584	643236

¹ All housings are white colored, flame-retardant, 94V-0, nylon material.
² Base numbers shown. Dash numbers indicate contacts with a pre-tin finish or a duplex finish.

Figure 3

3. TEST CONNECTORS (Figure 4)

Plug and cap test connectors are designed to mate with respective assembled plug and cap connectors and headers to test the electrical circuit. The test connectors are preloaded with spring-loaded contacts that will mate with pin or socket contacts in the connector. The 2.13 mm [.084 in.] diameter pin that extends out the BACK of the test connector will accept Universal MATE-N-LOK socket contacts.

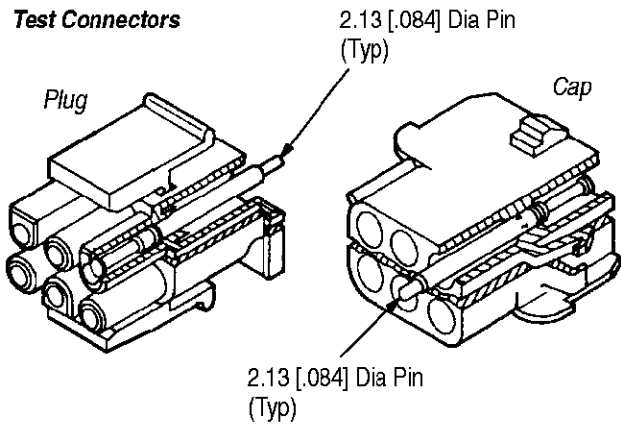

TEST CONNECTORS●		
NUMBER OF CIRCUITS	PLUG PART NUMBER	CAP PART NUMBER
2	350848-2	350849-2
3	350848-3	350849-3
4	350848-4	350849-4
5	350848-5	350849-5
6	350848-6	350849-6
9	350848-9	350849-9
12	1-350848-2	1-350849-2
15	1-350848-5	1-350849-5

● All housings are white colored, flame-retardant, 94V-0, nylon material. The test connectors have a 5 amp maximum current rating per circuit.

Figure 4

4. ACCESSORIES

Keying Plugs – Keying plugs provide additional polarization for the connectors. Refer to Instruction Sheet 408-3320 for insertion procedures.

Strain Relief Assembly – The strain relief assembly is designed to relieve the stress of the wires on the contacts. There are two strain relief versions (open and enclosed). Refer to Instruction Sheet 408-3320 for assembly procedures.

5. PANEL CUTOUT

The cap housing features flexible mounting latches and is designed for panel mounting. The TwistLok cap housing has a panel mount helix and is designed to insert into a panel by twisting clockwise until seated. Refer to the customer drawing or Application Specification 114-1010 for cutout dimensions.

6. PRINTED CIRCUIT BOARD LAYOUT

Headers are designed to be mounted and soldered onto pc boards. Refer to the customer drawing or Application Specification 114-1010 for layout dimensions.

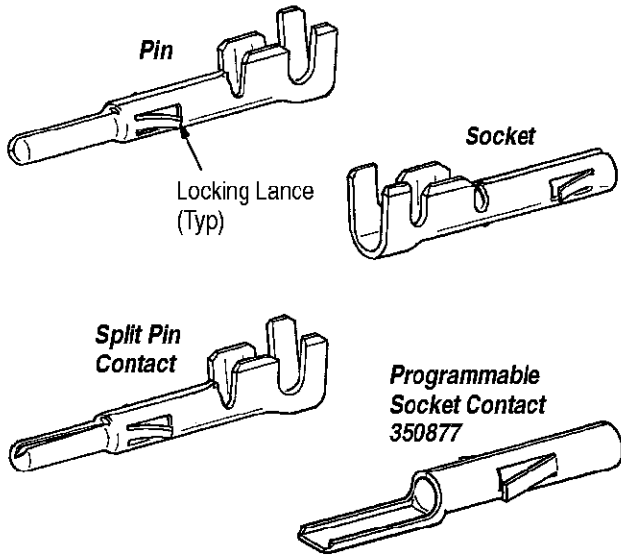

WIRE SIZE (AWG)	CONTACT		
	TYPE	LOOSE PIECE PART NUMBER	STRIP PART NUMBER
30 to 26	Pin	770672	350924
	Skt	770673	350925
24 to 18	Pin	350690	350561
	Skt	640347	350851
	Skt	350689	350570
	Pin●	350706	350699
	Pin●●	—	770210
20 to 14	Pin	350547	350218
	Skt	350550	350536
	Pin●	350705	350687
	Pin●●	350669	350654
	Pin	350552	350538
	Skt	350551	350537
	Pin●	350707	350700
18 to 14	Pin	350918	350873
	Skt	350919	350874
12 to 10	Pin	640309	350922
	Skt	640310	350923
	Pin●●	—	770234

● Split pin ●● Grounding pin – 2.54 [.100] longer than standard pin.

Figure 5

7. CONTACTS (Figure 5)

7.1. Selection

Refer to Figure 5 for wire size and pin and socket compatibility.

Pin and socket crimp contacts are available in strip form for machine crimping, and in loose piece form for hand tool crimping. Split pin contacts are recommended for use in housings having 6, 9, 12, and 15 circuits to reduce mating force. Grounding pin contacts (2.54 mm [.100 in.] longer than standard pin contacts) are designed for a mate first, break last grounding application. Programmable socket contacts are designed to accept 110 Series FASTON* receptacle terminals.

7.2. Crimping

Follow termination procedures shown in Application Specification 114-1010.

Strip form contacts are designed to be crimped with a heavy duty miniature applicator in an AMP semi-automatic or automatic machine. Consult your local AMP representative for assistance in selecting the machine that will best suit your needs.

Loose piece contacts are designed to be crimped with an AMP hand crimping tool. Read the instruction sheet packaged with the tool for the proper crimping procedure.

7.3. Insertion

An insertion tool is generally NOT required for inserting contacts into the housings. Pin and socket contacts may be inserted in either the plug or the cap housing, or they may be intermixed in each housing to provide additional keying combinations.

AMP Insertion Tool 455830-1 is available for inserting contacts crimped to small wire sizes. Refer to Instruction Sheet 408-7984 for insertion procedures.

7.4. Extraction

AMP Extraction Tool 318851-1 is designed for removing pin and socket contacts from plug and cap housings. Refer to Instruction Sheet 408-4371 for extraction procedures.

8. REVISION SUMMARY

Since the previous release of this instruction sheet, the following changes have been made:

Per EC 0990-1143-00

- Updated document to corporate requirements
- Added TwistLok Cap drawing and part numbers to table in Figure 1