



Model Number

PSE2-SC-02

Safety control unit

Features

- Safety control unit
- For evaluating safety thru-beam sensors PSE4-SL
- Safety category 3 according to EN61496-1
- 24 V DC supply voltage
- 1 safe output contact
- Performance level PLd (EN13849-1) is attainable
- Component of PSE4 modular system

Product information

This control interface works with the PSE4 Series and as a complete system consists of the control unit, sensors, a rubber sensor strip, and an optional aluminum mounting strip. The system has been tested within a temperature range of 5 °C to 55 °C in line with EN 1760-2 and is suitable for finger protection.

The control interface analyzes the signal from the sensors and is designed to be installed in a switch cabinet. The safety contact of the control interface is released by actuating the safety edge. With this control interface, the system as a whole meets the requirements for performance level d, cat. 3 in accordance with EN ISO 13849-1.

Dimensions

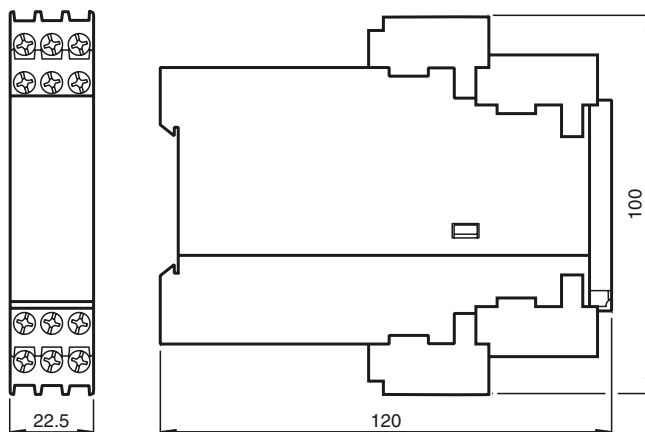

Electrical connection

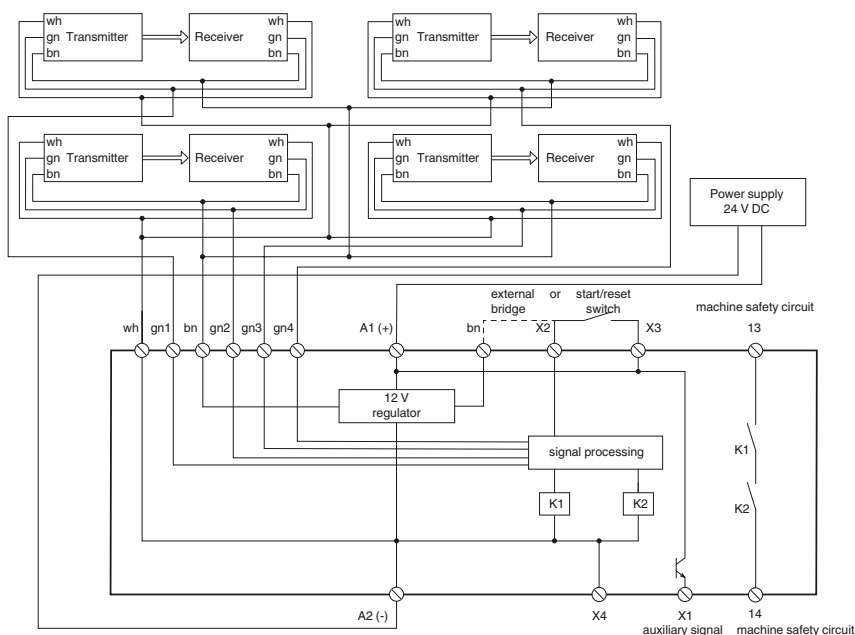

Release date: 2017-08-08 14:26 Date of issue: 2018-02-27 262534_eng.xml

Technical data**Limit data**

Permissible cable length	200 m
--------------------------	-------

Functional safety related parameters

Performance level (PL)	PL d
Category	Cat. 3
MTTF _d	109 a
Mission Time (T _M)	20 a
Diagnostic Coverage (DC)	87 %

Indicators/operating means

Operation indicator	LED green: Power on
Function indicator	LED green

Electrical specifications

Operating voltage	U _B	24 V DC +20/-10 % 24 V AC ± 10 %
Power consumption	P ₀	< 4 W
Surge protection		overvoltage category III

Output

Signal output	relay, 1 NO
Switching voltage	230 V AC / 24 V DC
Switching current	3 A AC / 4 A DC
Mechanical life	> 10 ⁷ switching cycles
Response time	18 ms

Output 1

Output type	Signal output, PNP, open collector
Switching voltage	U _B - 1 V
Switching current	max. 50 mA

Ambient conditions

Ambient temperature	5 ... 55 °C (41 ... 131 °F)
Pollution degree	2

Mechanical specifications

Degree of protection	IP20
Connection	screw terminals , lead cross section 2 x 1 mm ²
Material	PC / PA black
Mass	approx. 150 g

Compliance with standards and directives

Directive conformity	
Machinery Directive 2006/42/EC	EN 12978:2003+A1:2009
Standard conformity	
Functional safety	EN ISO 13849-1:2008 + AC:2009
Safety	EN ISO 13856-2:2013

Approvals and certificates

UL approval	cULus Listed File no: NRNT.E344450
TÜV approval	TÜV Rheinland 968/M 301.00/11

Notes**The PSE 2 module is comprised of the following components:****Safety thru-beam sensors PSE4-SL:**

The emitter and receiver housings are fully encapsulated to provide maximum protection against environmental influences such as water, dust and moisture and achieve degree of protection IP 68.

Sensor strips PSE4-RUB and PSE4-ROI:

The sensor strip has a two chamber design. The emitter and receiver are housed in the round top chamber. When the sensor strip is actuated, the optical channel is interrupted and the safety contacts on the control unit open. When actuation occurs in the end area, the emitter and receiver are pushed into the lower chamber to ensure that the light beam is broken. However, the force required is extremely high and the end areas become inactive as specified in EN 1760-2.

Safety control unit PSE2-SC:

The signal from the emitter/receiver system is evaluated as specified in EN ISO /IEC 61496-1 according to control category 3.

Aluminum rails PSE4-ALU:

Aluminum mounting rails are available in different lengths.

Operating principle

The emitter transmits pulses of infrared light, which are detected by the receiver. When the emitter light is detected, the receiver turns off the emitter via a control input. The "optical emission" stops. The receiver also detects this status and the emitter is then switched on again after a specified time. This coupling generates a dynamic signal sent to a buffer. The evaluation analyzes the charge state of the buffer.

Any errors in the emitter/receiver system affect the optical or electrical signal, which results in

Other suitable accessories can be found at www.pepperl-fuchs.com

the absence of a dynamic signal.

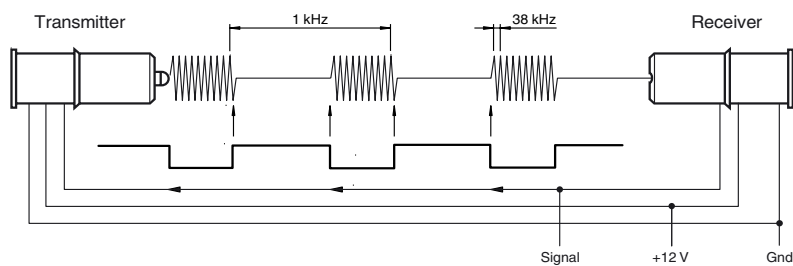

Note:

Only fully fitted safety edges comply with the examination certificate for the PSE2 series.

Possible combinations

	PSE4-ALU-*	PSE4-ALU-3009-*	PSE4-ROI-*	PSE4-RUB-*	PSE4-RUB-30EPDM58-*	PSE2-SC-*	PSE4-SC-*	PSE4-SL-*
PSE4-ALU-*			X	X	-	X	X	X
PSE4-ALU-3009-*			-	-	X	X	X	X
PSE4-ROI-*	X	-				X	X	X
PSE4-RUB-*	X	-				X	X	X
PSE4-RUB-30EPDM58-*	-	X				X	X	X
PSE2-SC-*	X	X	X	X	X			X
PSE4-SC-*	X	X	X	X	X			X
PSE4-SL-*	X	X	X	X	X	X	X	

Mounting or replacing the sensors

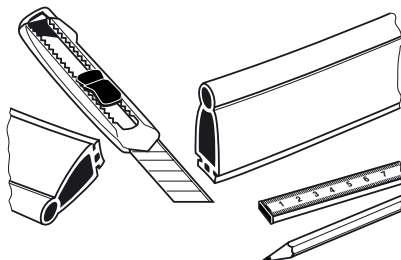

Sensor strip PSE4-RUB-XX or PSE4-ROI-XX and accompanying aluminum mounting strip
Cut PSE4-ALU-XX to the required length.

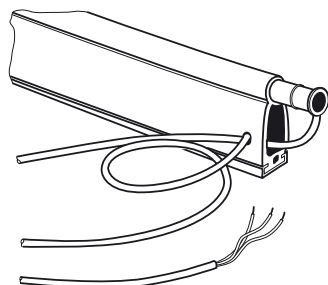

Slide the emitter and receiver into the upper chamber.
Guide the emitter cable through the lower chamber to the receiver side.

Release date: 2017-08-08 14:26 Date of issue: 2018-02-27 262534_eng.xml