

# Ionizer

## ● 3 types of the sensors are available.

- Autobalance sensor [High-precision type]  
Adjusts ion balance near the workpiece to reduce any interference!

**New**

- Autobalance sensor [Body-mounting type]



- Rapid elimination of static electricity by a feedback sensor: **0.3 seconds**

Conditions / Static buildup decreased from 1000 V to 100 V

Discharged object: Charged plate

(150 mm x 150 mm, capacitance 20 pF)

Installation distance: 200 mm (Tungsten electrode needle with air purge)

**Continuously emits ions in accordance with the polarity applied onto a workpiece.**

Supply pressure: 0.1 MPa (7  $\mu$ /min (ANR) per nozzle)

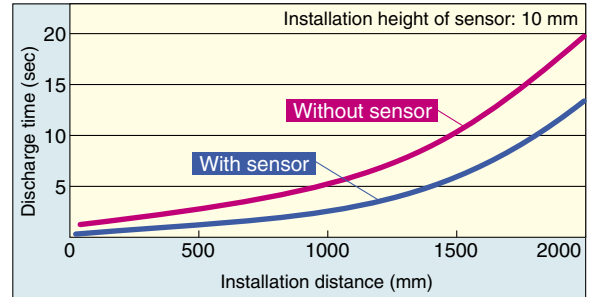

<Conditions> Static electricity elimination features are based on the data using the charged plate (size: 150 mm x 150 mm, capacitance: 20 pF) as defined in the U.S. ANSI standards (ANSI/ESD, STM3, 1-2000). Use this as a guideline purpose only for model selection because the value varies depending on the material and/or size of a subject.



Controlled ion balance with sensors

Series **IZS31** RoHS compliant





## Feedback sensor / Rapid elimination of static electricity

### Feedback sensor

Detects the polarity of a discharged object and measures the charged voltage.

### Rapid elimination of static electricity by a feedback sensor

- The speed of static electricity elimination has been increased by reading the workpiece's electrostatic potential by the feedback sensor and continuously emitting ions with a reverse polarity.

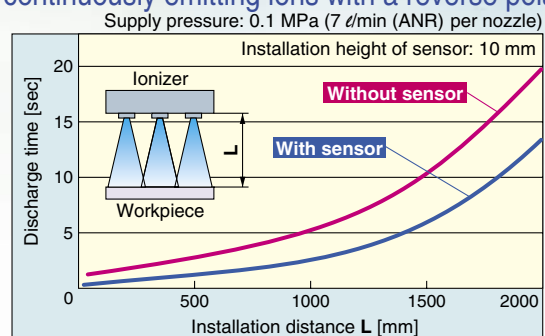
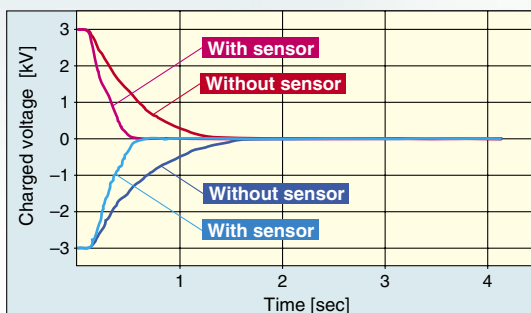

- Operation mode after static electricity removal (ion balance: within  $\pm 30$  V) can be selected.  
**Energy saving operation mode:** Stops generating ions after static electricity removal to reduce power consumption. Air consumption can also be reduced by controlling a pneumatic valve with a static electricity removal completion signal.

Note) The pneumatic valve must be separately procured.

- Continuous static electricity removal operation mode:** After static electricity elimination, the ionizer changes to pulse DC mode and continues to eliminate static electricity to make it approach 0 V even if the ion balance is below 30 V.

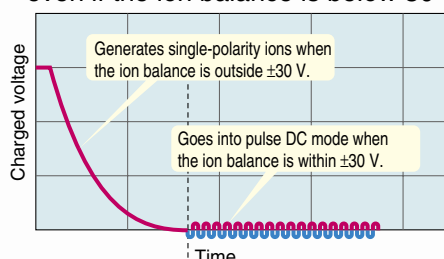

Mode	Ion emission waveform
Sensing DC Energy saving mode	+ [Solid red line] Stop - [Solid blue line]
Sensing DC Continuous static electricity elimination mode	+ [Pulsed red line] - [Pulsed blue line]
Pulse DC	+ [Pulsed red line] - [Pulsed blue line]
+ charged image	[Pulsed red line] Static electricity elimination completion

# Autobalance sensor / Reduction in adjustment and maintenance man-hours

## Autobalance sensor

Measures the ion balance condition.



### Autobalance sensor [High-precision type]

- The ion balance near the workpiece is accurately adjusted.
- The object is not affected by the height of installation or any interference.

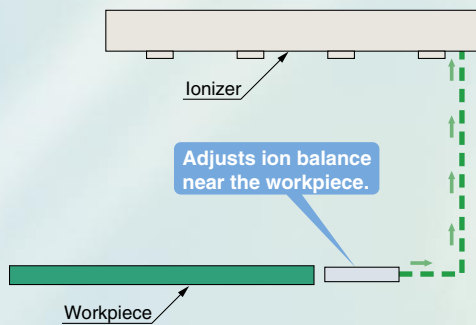

- “Ion balance adjustment to an external signal input” or “Ion balance adjustment at any time” can be selectable.
- The autobalance sensor may be connected only when adjusting the ion balance.

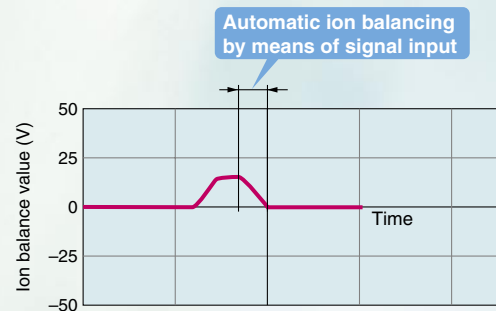

**New**

### Autobalance sensor [Body-mounting type] can be mounted on the body, and can be installed in any place

Monitoring the amount of ions emitted by an ionizer, the autobalance sensor maintains the initial ion balance by adjusting the +/- ion supply rate.



Autobalance sensor [Body-mounting type]

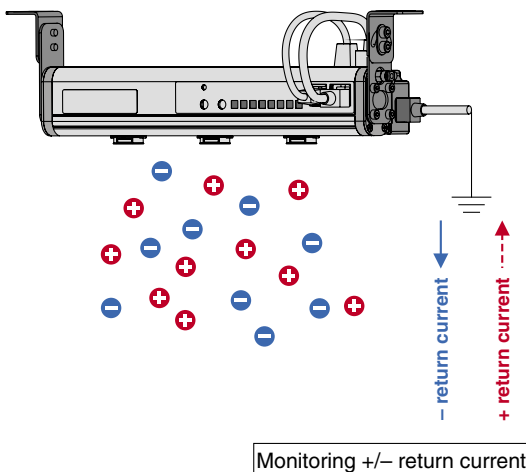

Monitoring +/- return current

#### Ion balance

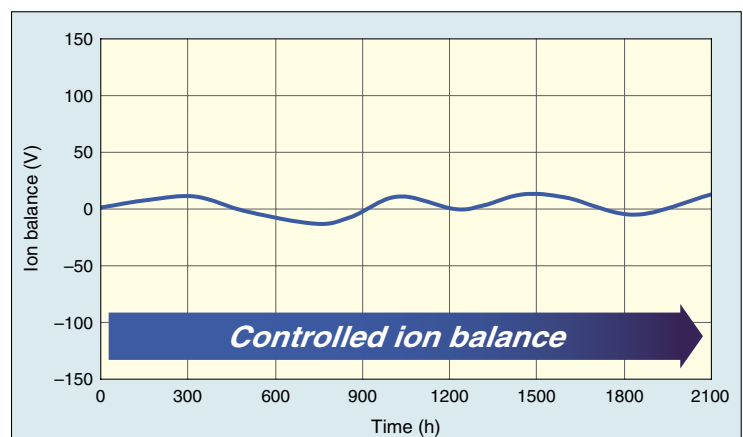

# Electrode cartridge variations

## ■ Electrode cartridge with rapid elimination of static electricity, focusing on discharge time and energy saving

[Electrode cartridge with rapid elimination of static electricity]

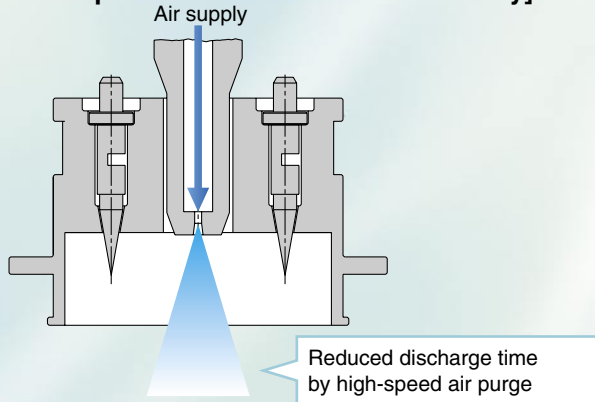

- High-efficiency nozzle design improves discharge time with low air consumption.

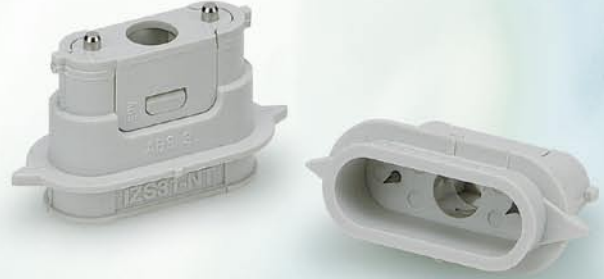

**New**

## ■ Electrode cartridge with low maintenance, focusing on ion balance and reduced maintenance time

[Electrode cartridge with low maintenance]

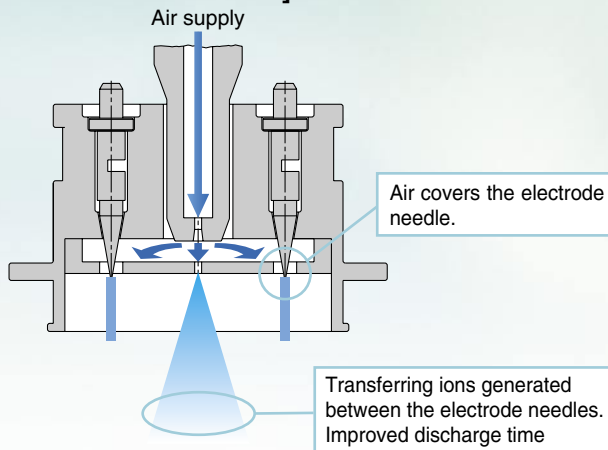

- Stain on electrode needle is reduced by supply compressed air.



**Electrode cartridge with low maintenance**  
Reduces stain on electrode needle.



**Conventional needle**  
Needs regular maintenance.

## ■ 3 types of electrode needle materials

- Tungsten: Ion balance  $\pm 30$  V
- Monocrystal silicon: Ion balance  $\pm 30$  V, suitable for eliminating static electricity onto silicon wafers
- Stainless steel\*: Ion balance  $\pm 100$  V, low-cost type, suitable for environments sensitive to heavy metal contamination such as food processing

\* Only for electrode cartridge with rapid elimination of static electricity



## ■ Applicable to workpieces moving at high speeds

- **Switching over frequency: Max. 60 Hz**  
Ions are discharged at high density to workpieces moving at high speed.

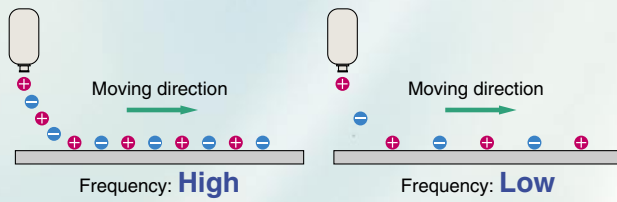

This reduces the range of surface potential fluctuations for short installation distances after static electricity elimination.

Note) The range of surface potential fluctuations varies depending on the object's material, etc.

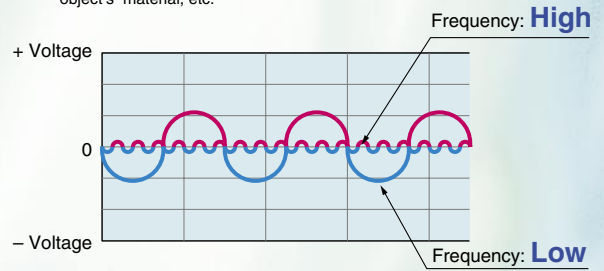

## ■ Effective static electricity elimination for short distances

- **Prevention of irregular static electricity elimination**  
Electrode cartridge 40 mm-pitch: **-X15**  
(Standard: 80 mm-pitch)  
(Length: 1260 mm or less)  
Note) 80 mm-pitch in case of air purge

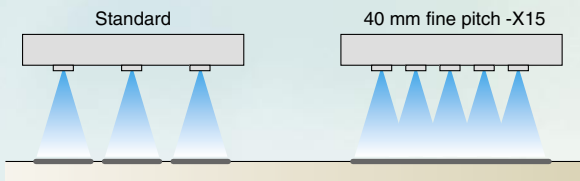
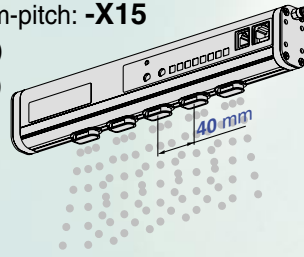

## ■ Applicable to purge pressure of 0.7 MPa

**Air purge: Yes, With sensor: 1 Hz/60 Hz**

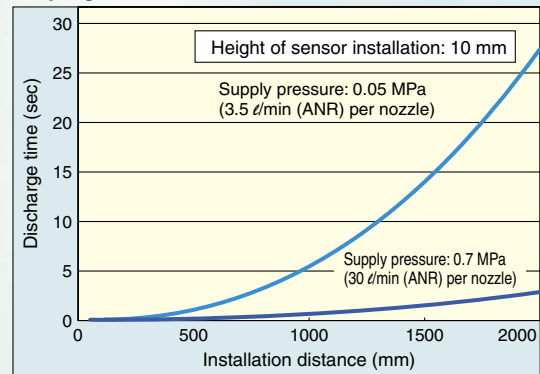

## ■ Indicator functions

- **Visualization of the charging condition**  
(During sensing DC mode)

Workpiece electric polarity	LED + OK -	Workpiece electric charge voltage	
Positive		+400 V or higher	
		+100 V to +400 V	
		+30 V to +100 V	
		Within ±30 V	
Negative		-30 V to -100 V	
		-100 V to -400 V	
		-400 V or lower	

- **Visualization of ion balance**  
(When pulse DC mode or the autobalance sensor are used.)



Contamination of the electrode needle can be checked at the same time.

Light ON: Within ±30 V  
Flash: Around ±30 V  
Light OFF and Alarm output: Adjustment is not possible.

## ■ Continuous ion emission of a desired polarity during DC mode

- Can be used to remove static electricity from fast-charged or high-potential workpieces or to electrostatically charge them.

## ■ Detects the electric potential difference and outputs in an analogue voltage. (During sensing DC mode)

- Outputs measured data at a 1 to 5 V level when a feedback sensor is used. By outputting the data to a PLC, it is possible to control static electricity.

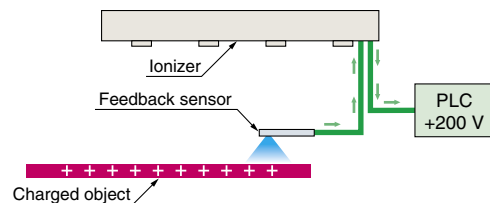

## ■ Safety functions

- **Electrode cartridge drop prevention**  
Locking by double-action



- **Security cover**  
Can prevent electrode cartridges from dropping off more reliably.



## Made to Order

### Ionizer / Series IZS31

Symbol	Contents	Specifications
X10	Non-standard bar length Model with 80 mm-pitch electrode cartridges	460, 540, 700, 860, 940, 1020, 1180, 1340, 1420, 1580, 1660, 1740, 1820, 1980, 2060, 2140, 2220
X14	Model with electrode cartridge security cover	The main unit is shipped fitted with an electrode cartridge security cover available as an option.
X15	Model with 40 mm-pitch electrode cartridges	This model comes fitted with electrode cartridges arranged at a 40 mm-pitch. (Standard pitch: 80 mm) Note) Maximum bar length is 1260 mm. The air purge nozzles are arranged at an 80 mm-pitch.
<b>New</b> X210	High-voltage/control unit detachable short type Model with 80 mm-pitch electrode cartridges	A short type ionizer (full length of 180 mm and 220 mm) can be installed in a small space. The high-voltage unit (ionizing unit) and control unit are detachable from each other. The distance between them is also optional according to the length of the selected connection cables.
<b>New</b> X211	High-voltage/control unit detachable short type Model with 40 mm-pitch electrode cartridges	
<b>Power cable</b>		
X13	Non-standard power cable length	Available in 1 m increments from 1 m to 20 m
<b>AC adapter</b>		
<b>New</b> X196EU	Ionizer driving AC adapter	Input voltage: 100 V to 240 V, Output voltage: 24 VDC

## Variations

### Bracket

#### End bracket

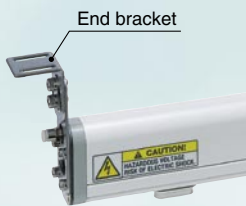

#### Center bracket

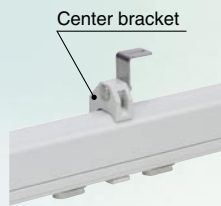

### Bar length (mm)

300, 380, 620, 780, 1100, 1260, 1500, 1900, 2300

### Power cable

3 m, 10 m

### Sensor

#### Feedback sensor



#### Autobalance sensor [High-precision type]



#### Autobalance sensor [Body-mounting type]

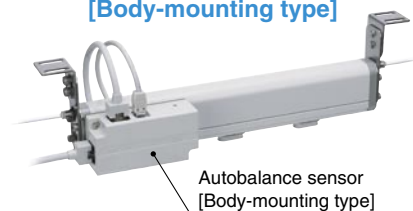

### Electrode cartridge

#### Electrode cartridge with rapid elimination of static electricity



Electrode needle material

- Tungsten
- Silicon
- Stainless steel

#### Electrode cartridge with low maintenance



Electrode needle material

- Tungsten
- Silicon

# Application Examples

## Eliminating static electricity on PET bottles

- Trip-resistance during conveying
- Prevents adhesion of dust.

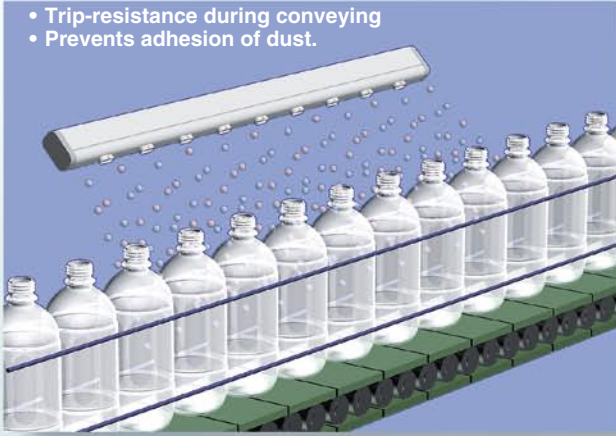

## Eliminating static electricity on a film

- Prevents adhesion of dust.
- Prevents winding failure due to wrinkles, etc.

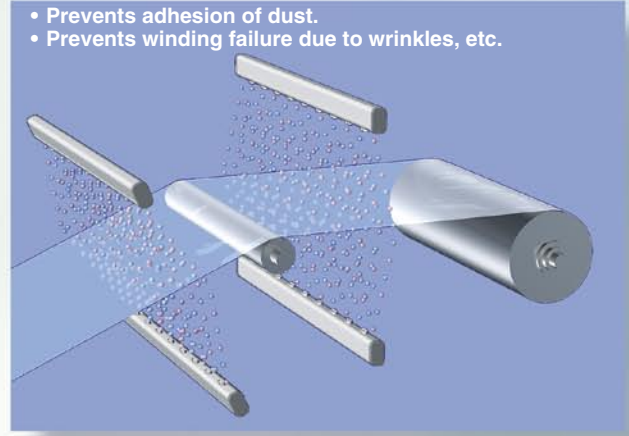

## Eliminating static electricity on molded goods

- Improves detachability of molded goods from a die.

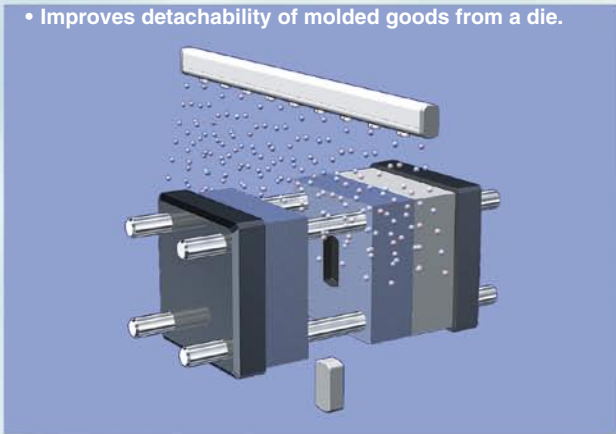

## Eliminating static electricity on film molded goods

- Prevents attaching to conveyer.
- Prevents dispersion of finished goods.

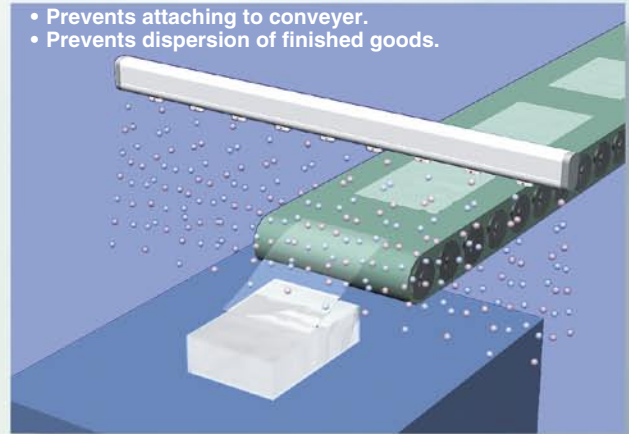

## Eliminating static electricity during wafer transfer

- Prevents breakage due to discharge between wafers and hands.

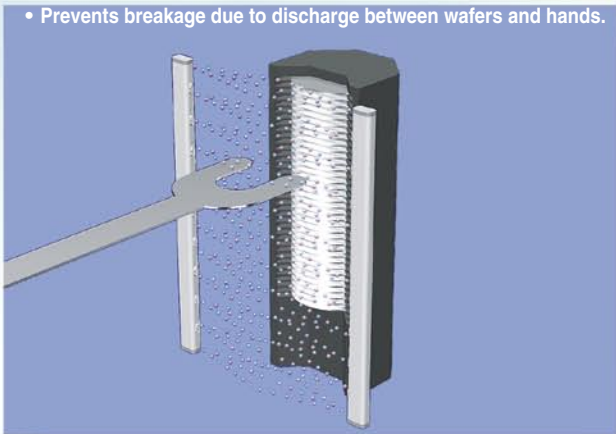

## Eliminating static electricity from packing films

- Prevents the filled substance from adhering to the packing film.
- Reduces packing mistakes.

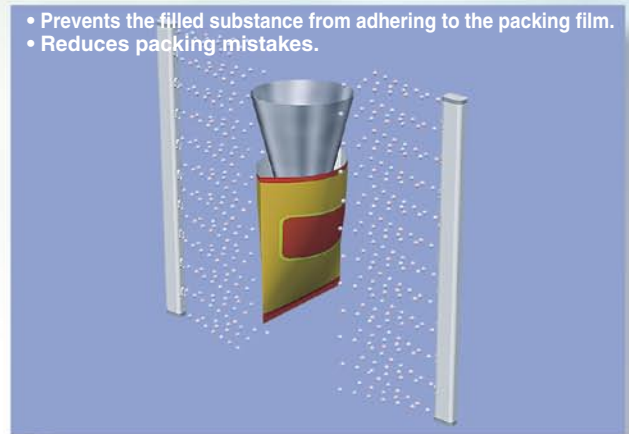

## Eliminating static electricity on an electric substrate

- Prevents element disruption due to discharge.
- Prevents adhesion of dust.

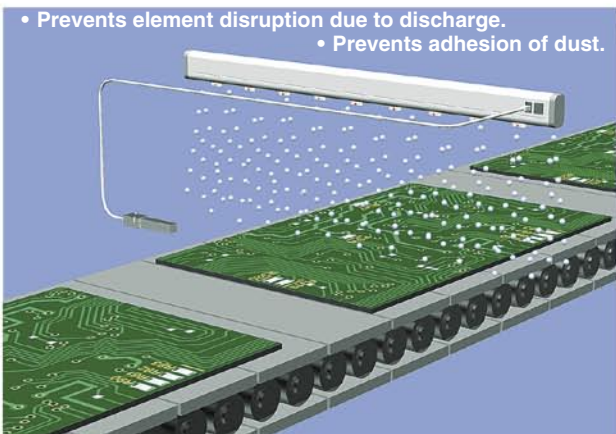

## Eliminating static electricity on a glass substrate

- Prevents breakage due to adhesion and discharge.
- Prevents adhesion of dust.

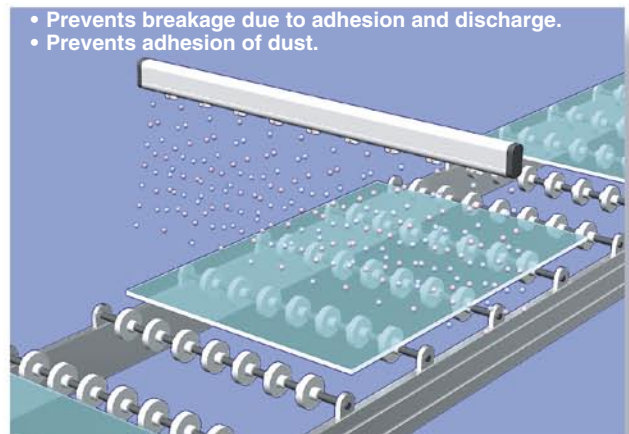



# Series IZS31

# Technical Data 1

## Static Electricity Elimination Characteristics

Note) Static electricity elimination features are based on the data using a charged plate (size: 150 mm x 150 mm, capacitance: 20 pF) as defined in the U.S. ANSI standards (ANSI/ESD, STM3, 1-2000). Use this as a guideline for model selection because the value varies depending on the material and/or size of a subject.

### 1) Installation distance and discharge time (Discharge time from 1000 V to 100 V)

#### Electrode cartridge with rapid elimination of static electricity

**Air purge: No**

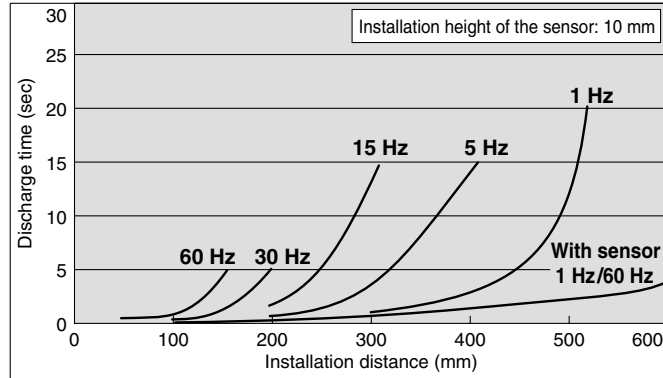

**Air purge: Yes Supply pressure: 0.02 MPa (1 l/min (ANR) per nozzle)**

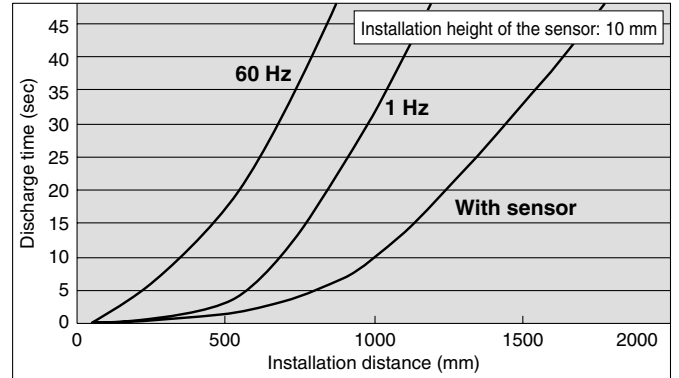

**Air purge: Yes Supply pressure: 0.05 MPa (3.5 l/min (ANR) per nozzle)**

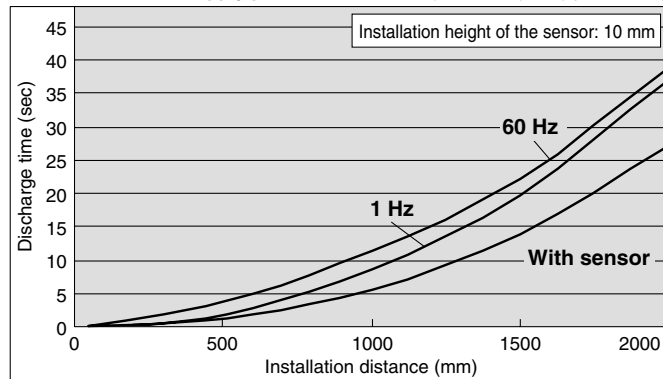

**Air purge: Yes Supply pressure: 0.1 MPa (7 l/min (ANR) per nozzle)**

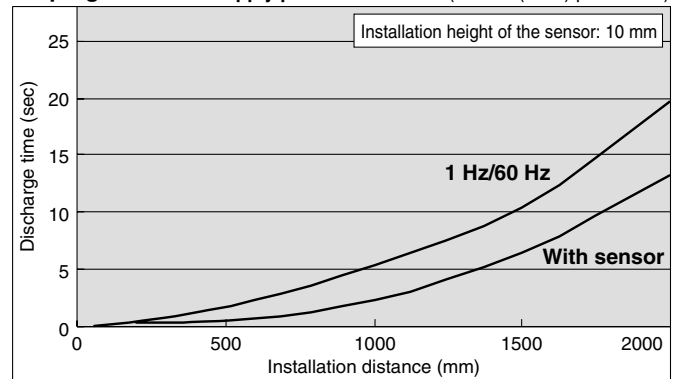

**Air purge: Yes Supply pressure: 0.3 MPa (14 l/min (ANR) per nozzle)**

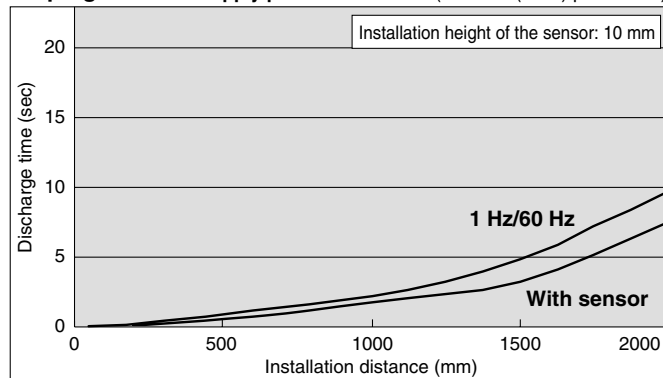

**Air purge: Yes Supply pressure: 0.5 MPa (20 l/min (ANR) per nozzle)**

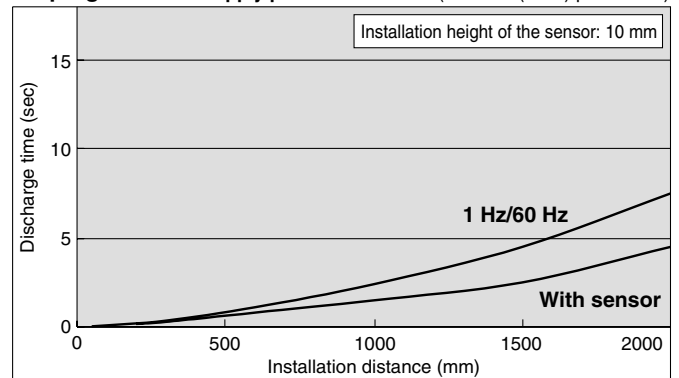

**Air purge: Yes Supply pressure: 0.7 MPa (30 l/min (ANR) per nozzle)**

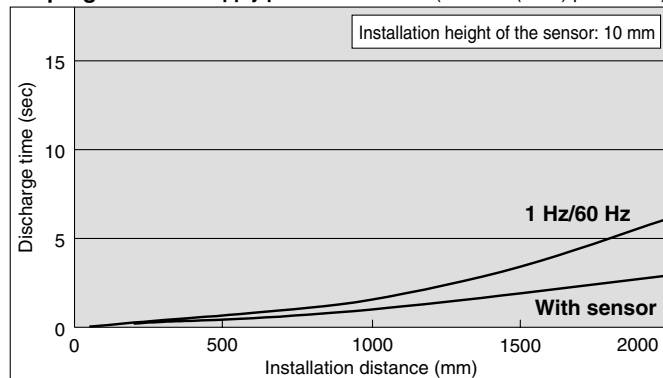



## Electrode cartridge with low maintenance

### ⚠ Caution

Be sure to perform air purge when using a low-maintenance electrode cartridge.  
Without air purge, low-maintenance efficiency will decrease.

**Air purge: Yes** Supply pressure: 0.02 MPa (1 ℓ/min (ANR) per nozzle)

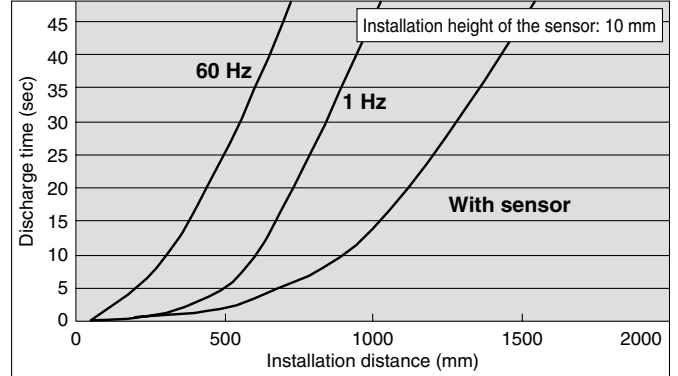

**Air purge: Yes** Supply pressure: 0.05 MPa (3.5 ℓ/min (ANR) per nozzle)

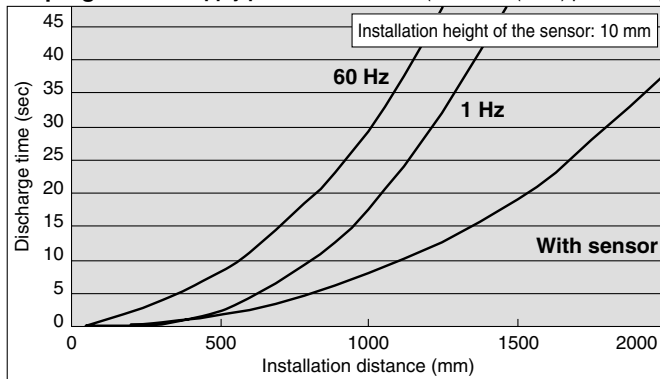

**Air purge: Yes** Supply pressure: 0.1 MPa (7 ℓ/min (ANR) per nozzle)

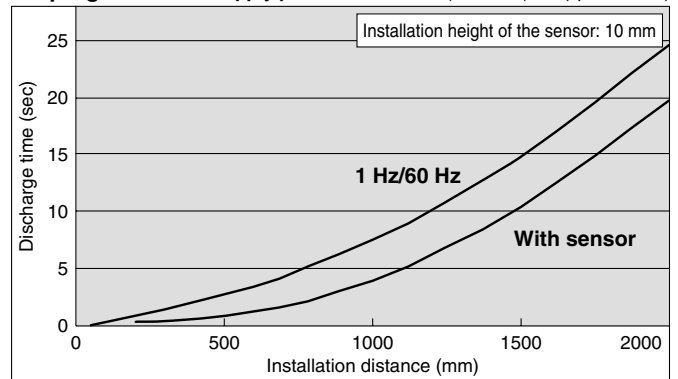

**Air purge: Yes** Supply pressure: 0.3 MPa (14 ℓ/min (ANR) per nozzle)

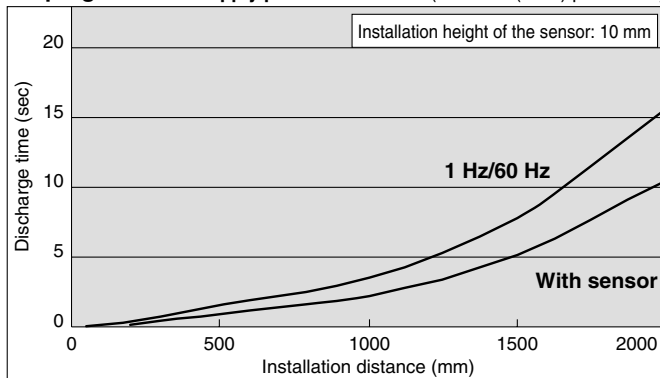

**Air purge: Yes** Supply pressure: 0.5 MPa (20 ℓ/min (ANR) per nozzle)

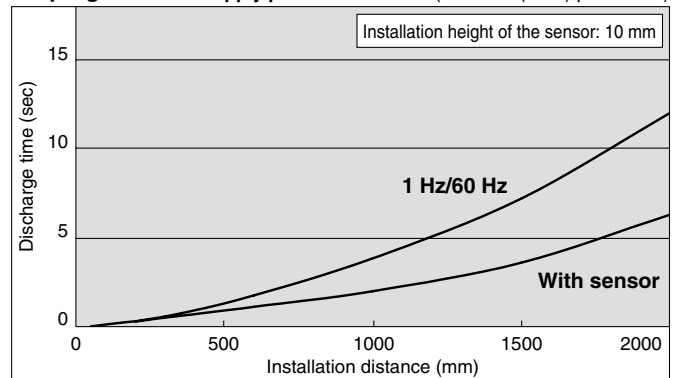

**Air purge: Yes** Supply pressure: 0.7 MPa (30 ℓ/min (ANR) per nozzle)

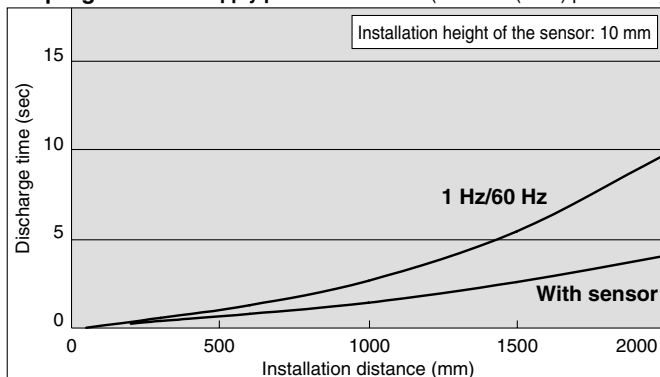

## Static Electricity Elimination Characteristics

Note) Static electricity elimination features are based on the data using a charged plate (size: 150 mm x 150 mm, capacitance: 20 pF) as defined in the U.S. ANSI standards (ANSI/ESD, STM3, 1-2000). Use this as a guideline for model selection because the value varies depending on the material and/or size of a subject.

### 2) Static electricity elimination range

#### Electrode cartridge with rapid elimination of static electricity

Air purge: No

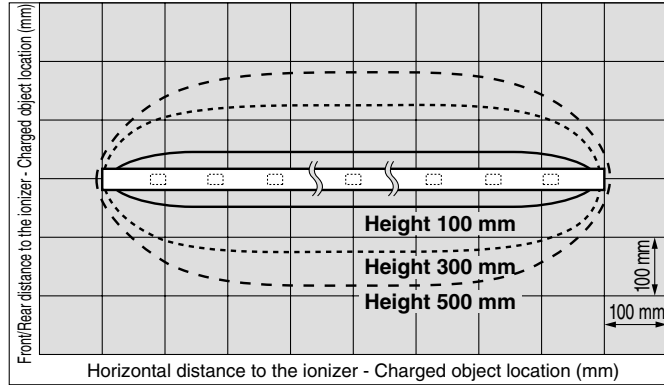

#### Electrode cartridge with rapid elimination of static electricity, electrode cartridge with low maintenance

Air purge: Yes (0.05 MPa to 0.7 MPa)

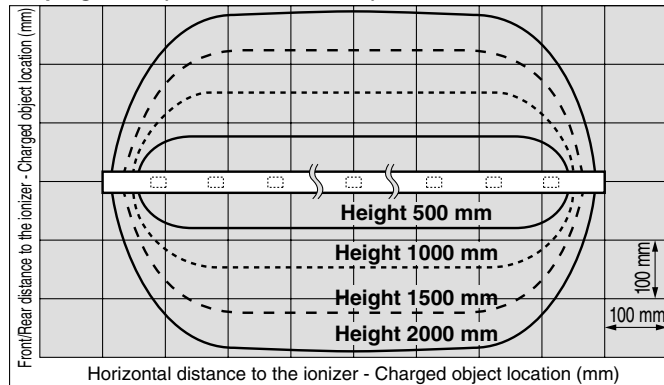

### 3) Installation height of the feedback sensor and discharge time / Ion balance

The height a feedback sensor is mounted at should be 50 mm or less. When using a feedback sensor at a height greater than 50 mm, refer to the below graphs.

Air purge: Yes (0.1 MPa)

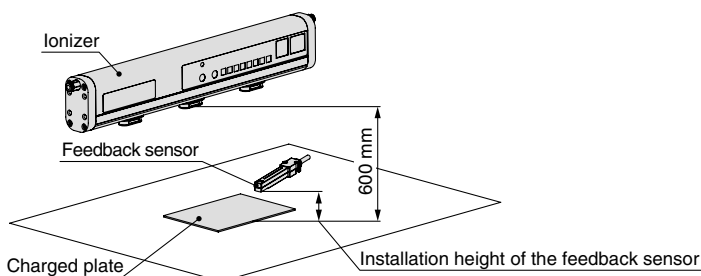
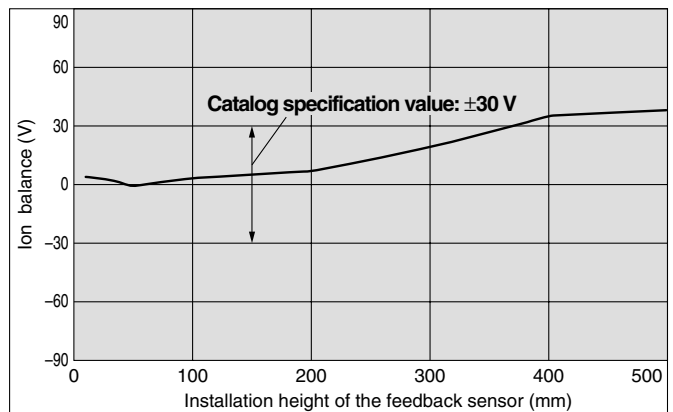
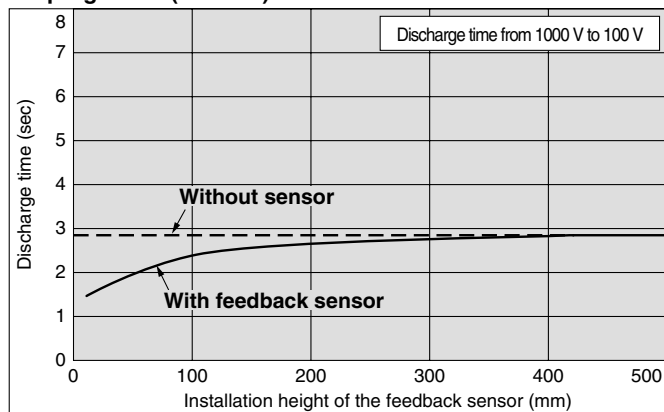

# Series IZS31

# Technical Data 3

## Static Electricity Elimination Characteristics

Note) Static electricity elimination features are based on the data using a charged plate (size: 150 mm x 150 mm, capacitance: 20 pF) as defined in the U.S. ANSI standards (ANSI/ESD, STM3, 1-2000). Use this as a guideline for model selection because the value varies depending on the material and/or size of a subject.

### 4) Flow rate — Pressure characteristics

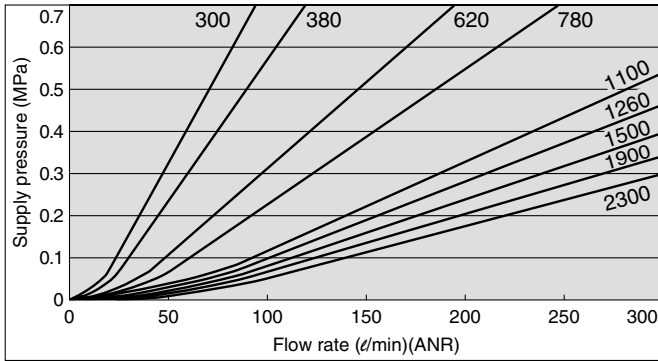

#### How to measure

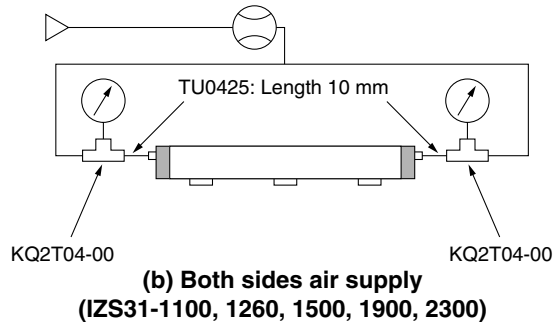
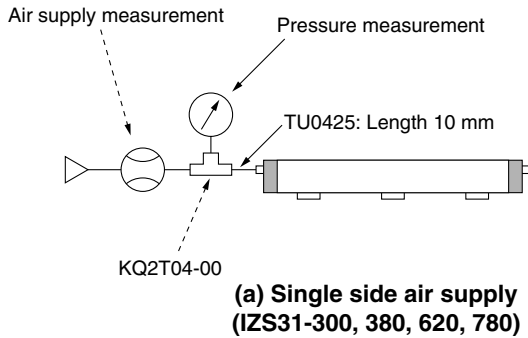

### Sensor Monitor Output (When a feedback sensor is used)

Note) The installation distance in the figure refers to the distance from the target to the electrostatic sensor.

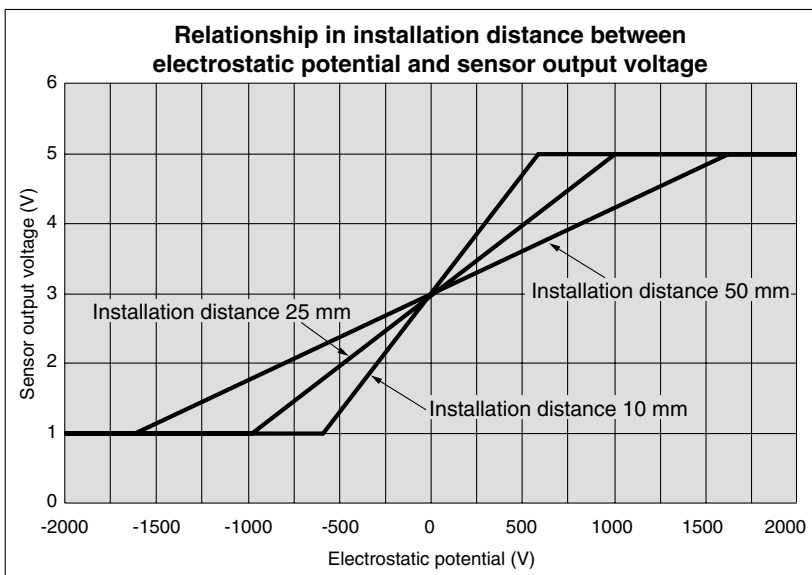

#### Feedback sensor detection range

The relationship between the installation distance of the electrostatic sensor and the detection range is as follows:

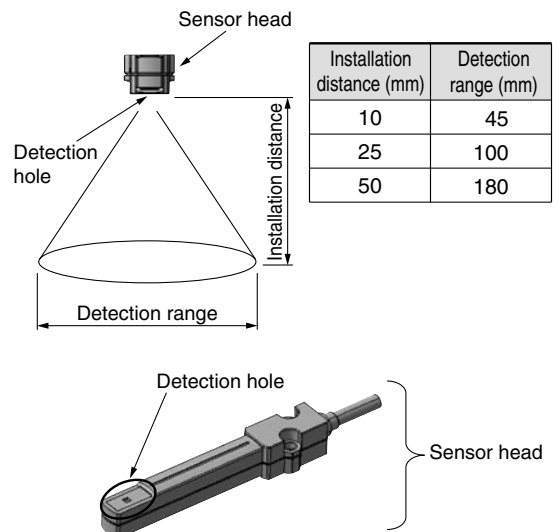

# Ionizer

# Series IZS31



## How to Order

**Ionizer**    **IZS31** - **780** [ ] [ ] [ ] - [ ] [ ] - [ ]

**Bar type**    **Made to Order**  
Refer to the table below.

**Bar length**

Symbol	Bar length
300	300 mm
380	380 mm
620	620 mm
780	780 mm
1100	1100 mm
1260	1260 mm
1500	1500 mm
1900	1900 mm
2300	2300 mm

**Electrode cartridge type / Electrode needle material**

Symbol	Electrode cartridge type	Electrode needle material
—		Tungsten
C	Rapid elimination of static electricity	Silicon
S		Stainless steel
J	Low maintenance	Tungsten
K		Silicon

**Output**

—	NPN output
P	PNP output

**Power cable**

—	With power cable (3 m)
Z	With power cable (10 m)
N	Without power cable

**Sensor**

—	Without sensor
E	Autobalance sensor [Body-mounting type]*
F	With feedback sensor
G	Autobalance sensor [High-precision type]

\* Connection cable A/B, with sensor bracket, but not assembled.

**Bracket (End bracket, Center bracket)**

—	Without bracket
B	With bracket <sup>Note)</sup>

Note) The number of center brackets differs depending on the bar length. (Refer to the table below.)

**Number of brackets**

Bar length (mm)	End bracket	Center bracket
300, 380, 620, 780	With 2 pcs.	None
1100, 1260, 1500		With 1 pc.
1900, 2300		With 2 pcs.

**Made to Order** (Refer to page 27 through 30 for details.)

## Ionizer / Series IZS31

Symbol	Contents	Specifications
X10	Non-standard bar length (80 mm-pitch)	460, 540, 700, 860, 940, 1020, 1180, 1340, 1420, 1580, 1660, 1740, 1820, 1980, 2060, 2140, 2220
X14	Model with electrode cartridge security cover	The main unit is shipped fitted with an electrode cartridge security cover available as an option.
X15	Model with 40 mm-pitch electrode cartridges	This model comes fitted with electrode cartridges arranged at a 40 mm-pitch. (Standard: 80 mm-pitch) Note) Maximum bar length is 1260 mm. The air purge nozzles are arranged at a 80 mm-pitch.
X210	High-voltage/control unit detachable short type	A short type ionizer (full length of 180 mm and 220 mm) can be installed in a small space. The high-voltage unit (ionizing unit) and control unit are detachable from each other. The distance between them is also optional according to the length of the selected connection cables.
X211	High-voltage/control unit detachable short type Model with 40 mm-pitch electrode cartridges	

## Non-standard power cable length

**How to Order**

**IZS31 - CP [ ] - X13**

**Power cable full length**

Symbol	Cable full length
01	1 m
02	2 m
19	19 m
20	20 m

Note 1) 11 m or longer power supply cables are not CE Marking-compliant.  
Note 2) Use standard power supply cables for 3 m and 10 m lengths.

## Ionizer driving AC adapter (100 to 240 VAC)

**How to Order**

**IZS31 - F [ ] - X196EU**

Power can be directly supplied from an AC source.  
The ionizer is driven at 100 to 240 VAC.

**Applicable output spec.**

—	NPN specification
P	PNP specification

## Individual Special Order

(Please contact an SMC sales representative.)

**Change in the direction of access to power cable**  
The direction of the access to the power cable is changed to the right side of the body.  
Note) The power cable is connected directly to the body. A connector is not used.

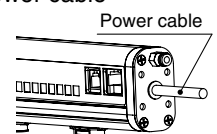



## Accessories

### Feedback sensor IZS31-DF



### Autobalance sensor [High-precision type] IZS31-DG



### Autobalance sensor [Body-mounting type] IZS31-DE

- Connection cable A/B (1 pc. each)
- Sensor bracket (1 pc.)
- Hexagon socket head cap screw for sensor bracket (2 pcs.)

Accessories



### Power cable

- IZS31-CP (3 m)
- IZS31-CPZ (10 m)



### Connection cable A/B for connecting the autobalance sensor to the body

- For driving:  
IZS31-CF (12P)



- For I/O signals:  
IZS31-CR (6P)



### Electrode cartridge with rapid elimination of static electricity

- IZS31-NT (Material: Tungsten)
- IZS31-NC (Material: Silicon)
- IZS31-NS (Material: Stainless steel)



### Electrode cartridge with low maintenance

- IZS31-NJ (Material: Tungsten)
- IZS31-NK (Material: Silicon)



### End bracket / IZS31-BE

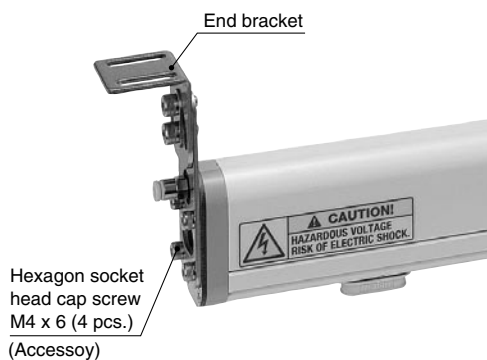

### Center bracket / IZS31-BM

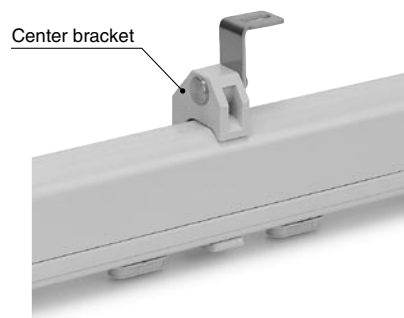

Note) The number of center brackets required, as listed below, depends on the bar length. Two end brackets are always required regardless of the bar length.

Bar length (mm)	Quantity	
	End bracket	Center bracket
300, 380, 620, 780	2 pcs.	None
1100, 1260, 1500		With 1 pc.
1900, 2300		With 2 pcs.

Note) The model number is for a single bracket.

### Sensor bracket / IZS31-BL (For mounting IZS31-DE on the body)

\*Provided with 2 hexagon socket head cap screw for sensor bracket (2 pcs.)

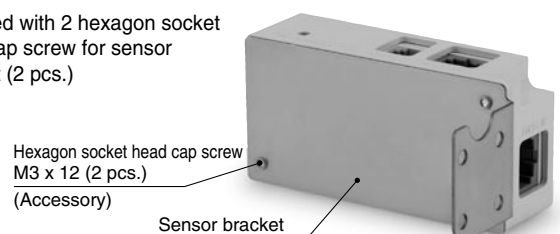

# Series IZS31

## Options

### Electrode cartridge security cover

## IZS31-E 3

#### Number of fixed electrode cartridges

IZS31-E3	3
IZS31-E4	4
IZS31-E5	5

#### Number of required security covers

Bar length (mm)	Number of required security covers		
	IZS31-E3	IZS31-E4	IZS31-E5
300	1	—	—
380	—	1	—
620	1	1	—
780	—	1	1
1100	3	1	—
1260	1	3	—
1500	—	2	2
1900	1	5	—
2300	—	2	4

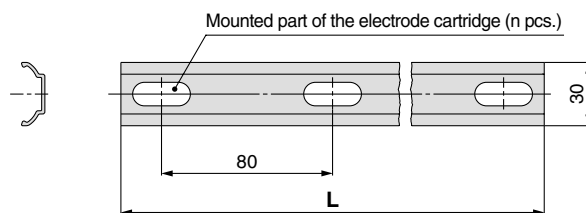

Part no	L
IZS31-E3	200
IZS31-E4	280
IZS31-E5	360

The model number requires the suffix “-X14” to indicate that the body is to be shipped fitted with an electrode cartridge security cover.

### IZS31 Standard part no. - X14

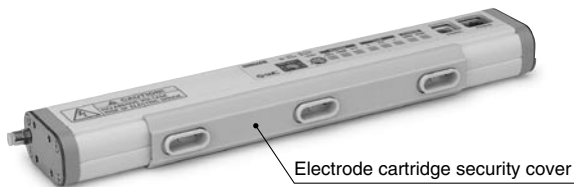

When attached to the body

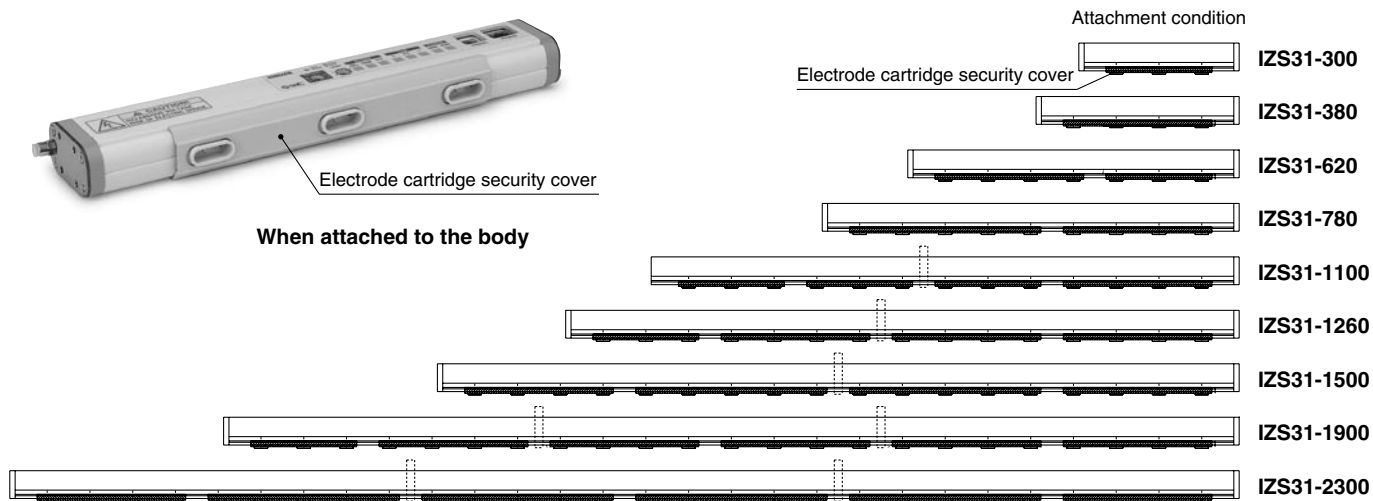

### Screwdriver for ion balance adjustment trimmer / IZS30-M1

### Electrode needle cleaning kit / IZS30-M2



## Specifications

Ionizer model		IZS31-□□ (NPN specification)	IZS31-□□P (PNP specification)
<b>Ion generation method</b>		Corona discharge type	
<b>Method of applying voltage</b>		Sensing DC, Pulse DC, DC	
<b>Electricity discharge output</b>		±7000 V	
<b>Ion balance</b> <small>Note 1)</small>		±30 V (Stainless steel electrode needle: ±100 V)	
<b>Air purge</b>	<b>Fluid</b>	Air (Clean and dry)	
	<b>Operating pressure</b>	0.7 MPa or less <small>Note 2)</small>	
	<b>Connecting tubing O.D.</b>	ø4	
<b>Power supply voltage</b>		24 VDC ±10%	
<b>Current consumption</b>	<b>Sensing DC mode</b>	200 mA or less (While standing by: 120 mA or less)	
	<b>Pulse DC mode</b>	Autobalance sensor [Body-mounting type]: 300 mA or less Autobalance sensor [High-precision type]: 200 mA or less When sensor is not used: 170 mA or less	
	<b>DC mode</b>	170 mA or less	
<b>Input signal</b>	<b>Electricity discharge stop signal</b>	Connected to GND (Voltage: 5 VDC or less, Current consumption: 5 mA or less)	Connected to +24 V (Voltage: Between 19 VDC and power supply voltage, Current consumption: 5 mA or less)
	<b>Maintenance signal</b>		
<b>Output signal</b>	<b>Static electricity removal completion signal</b>	Max. load current: 100 mA Residual voltage: 1 V or less (Load current at 100 mA) Max. applied voltage: 28 VDC	Max. load current: 100 mA Residual voltage: 1 V or less (Load current at 100 mA)
	<b>Maintenance output signal</b>		
	<b>Error signal</b>		
	<b>Sensor monitor output</b> <small>Note 3)</small>		
<b>Effective discharge distance</b>		50 to 2000 mm (Sensing DC mode: 200 to 2000 mm)	
<b>Ambient temperature, Fluid temperature</b>		0 to 50°C	
<b>Ambient humidity</b>		35 to 80% Rh (With no condensation)	
<b>Material</b>		Cover of ionizer: ABS, Electrode needle: Tungsten, Monocrystal silicon, Stainless steel	
<b>Vibration resistance</b>		Durability 50 Hz Amplitude 1 mm XYZ each 2 hours	
<b>Shock resistance</b>		10 G	
<b>Compliance with overseas standards/directive</b>		CE (EMC directive: 89/336/EEC, 92/31/EEC, 93/68/EEC, 2004/108/EC, Low voltage directive: 73/23/EEC, 93/68/EEC) UL U.S. Standard for Electrostatic Air Cleaner, UL857, fourth edition CSA Canadian Standard for Electrostatic Air Cleaner, CAN/CSA C22.2 No.187-M1986	

Note 1) When the air purge is performed between a charged object and an ionizer at a distance of 300 mm

Note 2) When a low maintenance type electrode cartridge is used, the operating pressure must be 0.05 MPa or more.

Note 3) When the potential of a charged object is measured with a feedback sensor, the relationship between the potential being measured, the sensor monitor output voltage and the detection range of the sensor may vary depending on the sensor's installation distance. Refer to page 4.

## Number of Electrode Cartridges/Weight

Bar length (mm)	300	380	620	780	1100	1260	1500	1900	2300
<b>Number of electrode cartridges</b>	3	4	7	9	13	15	18	23	28
<b>Weight (g)</b>	470	530	720	850	1100	1220	1410	1730	2040

## Sensor

Sensor model	IZS31-DF (Feedback sensor)	IZS31-DG (Autobalance sensor [High-precision type])	IZS31-DE (Autobalance sensor [Body-mounting type])
<b>Ambient temperature</b>	0 to 50°C		
<b>Ambient humidity</b>	35 to 85% Rh (With no condensation)		
<b>Case material</b>	ABS	ABS, Stainless steel	ABS
<b>Vibration resistance</b>	Durability 50 Hz Amplitude 1 mm XYZ each 2 hours		
<b>Shock resistance</b>	10 G		
<b>Weight</b>	200 g (Including cable weight)	200 g (Including cable weight)	110 g (Including cable weight)
<b>Installation distance</b>	10 to 50 mm (Recommended)	—	
<b>Compliance with overseas standards/directive</b>	CE (EMC directive: 89/336/EEC, 92/31/EEC, 93/68/EEC, 2004/108/EC, Low voltage directive: 73/23/EEC, 93/68/EEC)		

## Construction

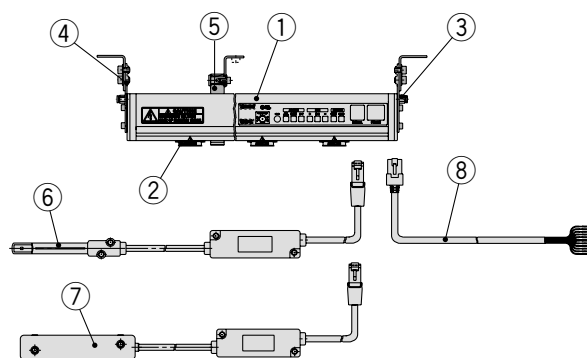

No.	Description
1	Ionizer
2	Electrode cartridge
3	One-touch fitting
4	End bracket
5	Center bracket
6	Feedback sensor
7	Autobalance sensor [High-precision type]
8	Power cable
9	Autobalance sensor [Body-mounting type]
10	Connection cable A (12P)
11	Connection cable B (6P)
12	Sensor bracket

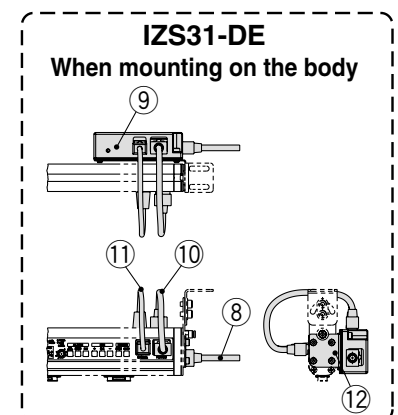

## Functions

### 1. Operation mode

There are 3 different operation modes (Sensing DC mode/Pulse DC mode/DC mode) for Series IZS31, which can be selected based on the application and operating condition.

#### (1) Sensing DC mode

The discharge time is reduced by detecting the workpiece's charge condition with a feedback sensor which feeds the data back to the ionizer and causes ions with the polarity best suited for static electricity elimination to be emitted. The static electricity elimination completion signal turns off when the workpiece's electrostatic potential falls within  $\pm 30$  V. <sup>Note)</sup>

This mode is suited for eliminating static electricity from heavily charged workpieces.

Either "Energy Saving Mode" or "Continuous Static Electricity Elimination Mode" can be selected depending on the ionizer's operation after static electricity elimination is completed.

Energy saving mode	The ionizer stops discharging automatically after the of static electricity elimination is completed. It resumes discharging when the workpiece's electrostatic potential exceeds $\pm 30$ V. <sup>Note)</sup> For static electricity elimination from conductive workpieces, "Energy Saving Mode" is recommended.
Continuous static electricity elimination mode	Even after the completion of static electricity elimination, this method continues to eliminate static electricity using DC pulses while controlling the ion balance, so that the workpiece's electrostatic potential falls within $\pm 30$ V. <sup>Note)</sup> For static electricity elimination from nonconductive workpieces, "Continuous Static Electricity Elimination Mode" is recommended.

Note) When the feedback sensor is installed at a height of 25 mm.

#### (2) Pulse DC mode

Alternatively emits positive and negative ions.

##### ● When an autobalance sensor (high-precision type) is used.

When an autobalance sensor is used, the ionizer automatically adjusts the ion balance to  $\pm 30$  V.

If the ion balance exceeds  $\pm 30$  V due to electrode needle contamination, the ionizer outputs a maintenance output signal.

The ion balance is adjusted and retained at the position of the workpiece. This mode is suited for eliminating spatial static electricity or preventing workpieces from becoming electrostatically charged.

Either "Manual Operation" or "Automatic Operation" can be selected depending on the method of ion balance adjustment.

Manual operation	When a maintenance start signal is input or the ionizer is turned on, this method adjusts the ion balance. For static electricity elimination from moving workpieces, "Manual Run" is recommended. Start system operation after the completion of ion balance adjustment.
Automatic operation	This method continuously adjusts the ion balance. For static electricity elimination from stationary workpieces or spatial static electricity elimination, "Automatic Run" is recommended.

##### ● When an autobalance sensor (body-mounting type) is used.

Controls the initial ion balance. If the ion balance cannot be kept due to electrode needle contamination, the ionizer outputs a maintenance output signal. Use a balance adjustment trimmer to set the ion balance (requires a separate measuring instrument to verify the ion balance).

Autobalance sensor [Body-mounting type]

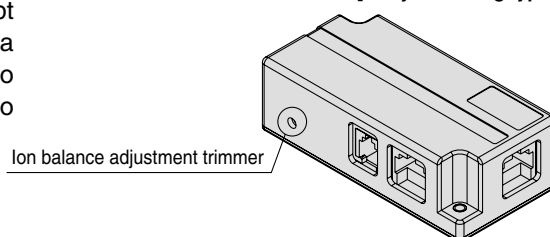

##### ● When a sensor is not used.

Use a balance adjustment trimmer to adjust the ion balance. This requires the separate use of a measuring instrument to verify the ion balance.

#### (3) DC mode

Continuously emits positive and negative ions. Parts other than the workpiece need to be appropriately grounded to prevent them from being charged. This mode cannot emit both positive and negative ions at the same time.



## Functions

### 2. Contamination-detection on an electrode needle

When a maintenance start signal is input, the ionizer detects any deterioration that may interfere with the electrode needles' capability to eliminate static electricity. If the needles need to cleaning due to such deterioration, the maintenance indicator LED comes on and the maintenance output signal turns ON. Ion emission continues even if the maintenance output signal is turned ON.

Note) Deterioration in the static electricity elimination capability cannot be detected by only connecting a feedback sensor, autobalance sensor [high-precision type], or autobalance sensor [body-mounting type]. Verify the capability by periodically inputting a maintenance start signal.

### 3. Display/Setting component description

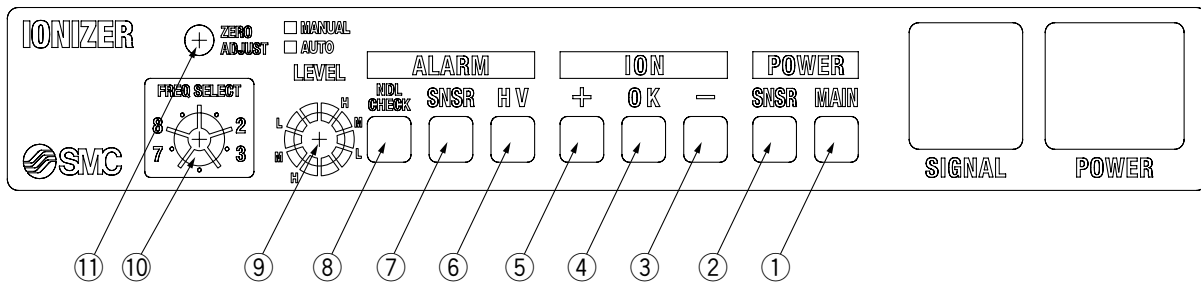

No.	Description	Type	Contents
1	<b>Power supply display</b>	LED (Dark green)	Illuminates when power is supplied. Blinks when the supply voltage is irregular.
2	<b>Sensor display</b>	LED (Dark green)	Illuminates when the feedback sensor, autobalance sensor [high-precision type] or autobalance sensor [body-mounting type] is connected.
3	<b>Negative display</b>	LED (Blue)	Functionality differs depending on the operation mode. Refer to "Model Selection and Settings" on page 13, 17, 20.
4	<b>Static electricity elimination completion display</b>	LED (Dark green)	
5	<b>Positive display</b>	LED (Orange)	
6	<b>Irregular high-voltage display</b>	LED (Red)	Illuminates when an abnormal current flows through an electrode needle.
7	<b>Irregular sensor display</b>	LED (Red)	Illuminates when the feedback sensor, autobalance sensor [high-precision type] or autobalance sensor [body-mounting type] is not operating normally.
8	<b>Maintenance display</b>	LED (Red)	Illuminates when the electrode needle contamination is detected. Blinks while the contamination is being detected.
9	<b>Maintenance level selection switch</b>	Rotary switch	Functionality differs depending on the operation mode. Refer to "Model Selection and Settings" on page 11, 15, 16, 19.
10	<b>Frequency selection switch</b>	Rotary switch	
11	<b>Balance adjustment trimmer</b>	Trimmer	Used to adjust the ion balance when the autobalance sensor [high-precision type] or autobalance sensor [body-mounting type] is not used.

## Model Selection and Settings 1 / Sensing DC Mode

**1. Sensing DC mode** (Refer to page 15 when using the ionizer in the pulse DC mode, or refer to page 19 when using it in the DC mode.)

### 1) Bar length selection

- Select the appropriate length suited for a workpiece size by referring to “Static Electricity Elimination Characteristics” and “Static Electricity Elimination Range”.

### 2) Ionizer installation

- Install the ionizer within 200 to 2000 mm. Although the ionizer can also be used at other distances, it may fail to operate normally depending on the conditions of use. Before use, always verify that the ionizer is functioning normally.

### 3) Sensor installation

- Install the feedback sensor with the detection hole facing the charged surface.
- Installation at a height from 10 to 50 mm is recommended. Although the sensor can also be used at other heights, it may fail to operate normally depending on the conditions of use. Before use, always verify that the sensor operates normally. (Refer to “Installation height of feedback sensor and discharge time/ion balance” on page 3 as a guide.)
- When the ionizer and feedback sensor are connected, the sensing DC mode is automatically selected.

### 4) Contamination-detection level setting on an electrode needle

- Maintenance level selection switch
- Set the switch to either H (High), M (Middle), L (Low). At settings other than these, the ionizer does not perform the electrode needle contamination-detection.

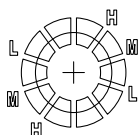

H (High).....Level that does not affect the discharge time.  
 M (Middle)....Level at which the discharge time is a little bit longer than it was initially.  
 L (Low).....Level at which the discharge time is longer than it was initially.

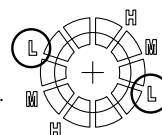

\* Settings with the same letter share the same level.

Note) Contamination-detection starts when a maintenance start signal is input.

### 5) Frequency selection switch setting

- Select “Energy Saving Mode” or “Continuous Static Electricity Elimination Mode”.
- In case of “Continuous Static Electricity Elimination Mode”, select the ion generation frequency after static electricity elimination is completed.

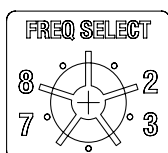

		Details of operation	Switch setting
Energy saving mode	Automatically stops emitting electricity even after static electricity elimination is completed.	<p>+ ion</p> <p>— ion</p> <p>Stop</p>	
Continuous static electricity elimination mode	Continuously eliminates static electricity with pulse DC by controlling the ion balance so that the charged potential on a workpiece would be within $\pm 30V$ even after static electricity elimination is completed. The ionizer generates ions at the preset frequency.	<p>+ ion</p> <p>— ion</p> <p>Pulse operation</p> <p>(Example) Charged object workpiece: negative electric charge</p> <p>Static electricity elimination completion</p>	<p>0...1 Hz</p> <p>1...3 Hz</p> <p>2...5 Hz</p> <p>3...10 Hz</p> <p>4...15 Hz</p> <p>5...20 Hz</p> <p>6...30 Hz</p> <p>7...60 Hz</p>

## Model Selection and Settings 1 / Sensing DC Mode

### 6) Wiring of the power supply cable

- Connect the dedicated power supply cable.

#### ■ Connection with the ionizer driving power supply

Symbol	Cable color	Description	Connection needs	Contents
DC1(+)	Brown	Power supply 24 VDC	○	Ionizer driving power supply cable
DC1(-)	Blue	Power supply GND [FG]	○	
OUT4	Dark green	Sensor monitor output	△	Outputs the workpiece's electrostatic potential as an analogue signal. (1 to 5 V)

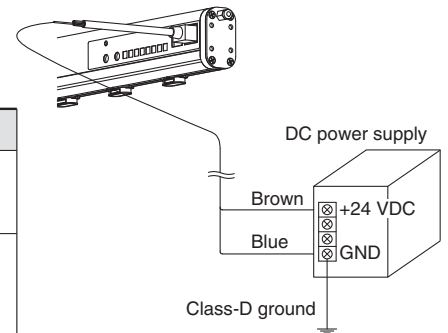

\* DC1 (-) [Blue] may be grounded according to Class-D. If the terminal is not grounded, the ionizer may malfunction.

#### ■ Connection with the input/output signal power supply cable

Symbol	Cable colour	Description	Connection needs	Contents
DC2(+)	Red	Power supply 24 VDC	○	Input/Output signal power supply cable
DC2(-)	Black	Power supply GND	○	
IN1	Light green	Discharge stop signal	○	Signal for enabling/disabling discharge (NPN spec.) Discharge is enabled when connected to DC2 (-) [Black] (PNP spec.) Discharge is enabled when connected to DC2 (+) [Red]
IN2	Grey	Maintenance start signal	△	Input signal when determining the necessity of electrode needle maintenance
-	White	-	-	-
-	Orange	-	-	-
OUT1	Pink	Static electricity elimination completion signal	△	Turned ON when the workpiece's electrostatic potential is greater than $\pm 30$ V or when electrode needle contamination is detected.
OUT2	Yellow	Maintenance output signal	△	Turned ON when electrode needle maintenance is necessary.
OUT3	Purple	Abnormal signal	△	Turned ON in normal operation. Turned OFF in case of high-voltage error, sensor error, CPU error.

○: Minimum wiring requirement for ionizer operation

△: Wiring necessary to use various functions

- : Wiring not required in the sensing DC mode. Ensure that this wire does not short-circuit to other wires.

### 7) Air piping

- For single-side piping, block the unused port with the M-5P plug supplied with the ionizer.

## Model Selection and Settings 1 / Sensing DC Mode

### 8) LED display

■ **POWER LED**...Indicates the state of the power input and the sensor connection.

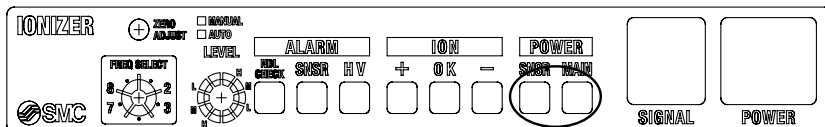

LED		Function
POWER	MAIN	Illuminates when power is supplied. (Dark green) (Blinks when the power supply is irregular.)
	SNSR	Illuminates when the feedback sensor is connected. (Dark green)

■ **ION LED**...Indicates the workpiece state of electrostatic charging.

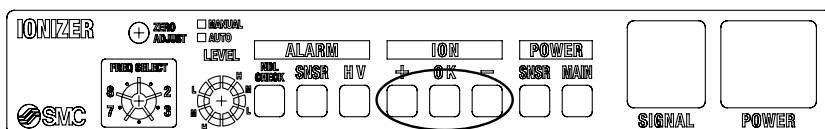

LED		Function
ION	+	Illuminates when the workpiece is positively charged. (Orange)
	OK	Illuminates when the workpiece electrostatic potential is low. (Dark green)
	-	Illuminates when the workpiece is negatively charged. (Blue)

· The workpiece state of electrostatic charge can be checked by reading the LED displays.

Workpiece electric polarity	LED + OK -	Workpiece electric charge voltage	■ Light ON ■ Blinking at 4 Hz □ Light OFF
Positive	■ □ □	+400 V or higher	
	■ □ □	+100 V to +400 V	
	■ ■ □	+30 V to +100 V	
	□ ■ □	Within ±30 V	
Negative	□ ■ ■	-30 V to -100 V	
	□ □ ■	-100 V to -400 V	
	□ □ ■	-400 V or lower	
	□ □ ■	-400 V or lower	

■ **ALARM LED**...Indicates abnormal states of the ionizer.

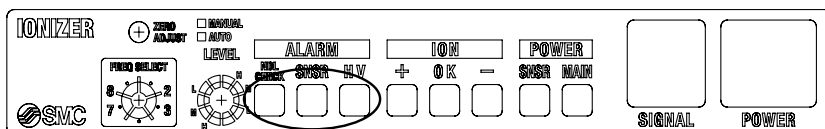

LED		Function
ALARM	HV	Illuminates when an abnormal current flows through an electrode needle. (Red)
	SNSR	Illuminates when the feedback sensor is not operating normally. (Red)
	NDL CHECK	Illuminates when electrode needle contamination is detected. (Red) (Blinks while contamination is being detected.)

## Model Selection and Settings 1 / Sensing DC Mode

### 9) Alarm

Alarm	Description	Corrective actions
High-voltage error	Occurrence of an abnormal current, such as high-voltage leakage. The ionizer stops ion emission, turns on the HV ALARM indicator, and turns OFF the error signal (OUT3).	Turn the power supply OFF, solve the problem, then turn the power supply on again. Alternatively, switch the discharge stop signal from OFF to ON.
Sensor error	The feedback sensor has become unable to operate normally. The ionizer stops ion emission, turns on the SNSR ALARM indicator, and turns OFF the error signal (OUT3).	Turn the power supply OFF, solve the problem, then turn the power supply on again. Alternatively, switch the discharge stop signal from OFF to ON.
CPU error	Failure in the CPU due to noise, etc. The ionizer stops ion emission, all of the LED indicators blink, and turns OFF the error signal (OUT3).	Turn the power supply OFF, solve the problem, then turn the power supply on again. Alternatively, switch the discharge stop signal from OFF to ON.
Electrode needle maintenance	Electrode needle maintenance is necessary. The NDL CHECK ALARM indicator comes on and a maintenance output signal (OUT2) turns ON.	Turn the power supply OFF, clean or replace the electrode needles, and turn the power supply on again.

### 10) Timing chart

#### ■ Timing chart in normal operation

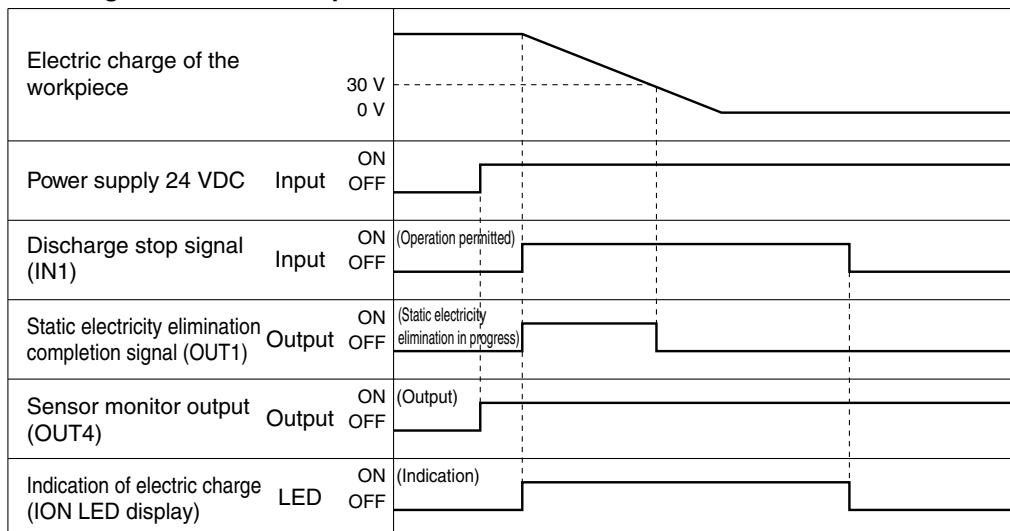

#### ■ Timing chart when electrode needle contamination is detected.

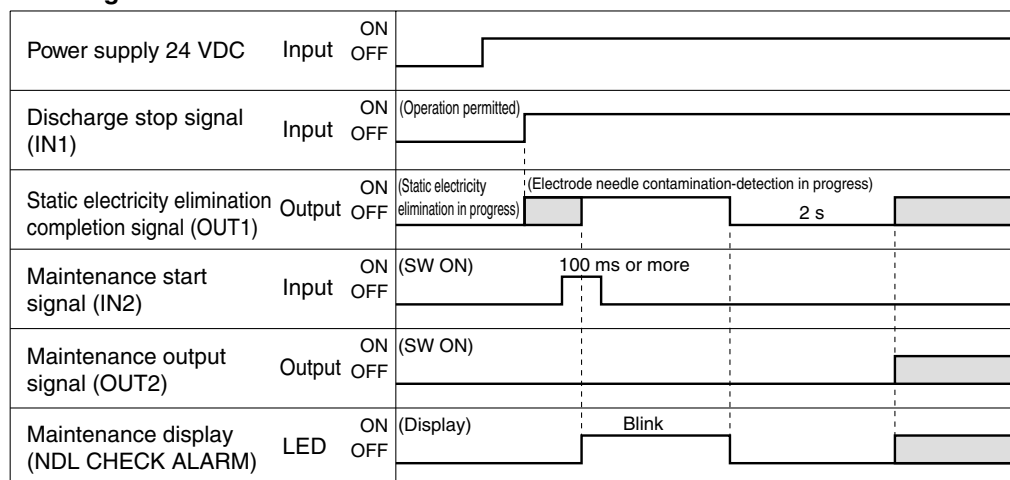

■ : Either ON or OFF depending on the situation

- Static electricity elimination completion signal is turn on when the electrode needle contamination-detection is in progress.

### ⚠ Caution

Ions are emitted from the ionizer to detect electrode needle contamination and the workpiece may therefore be electrostatically charged. Perform this detection procedure in the absence of workpieces.

## Model Selection and Settings 2 / Pulse DC Mode

### 2. Pulse DC mode

#### 1) Bar length selection

- Select the appropriate length suited for a workpiece size by referring to “Static Electricity Elimination Characteristics” and “Static Electricity Elimination Range”.

#### 2) Ionizer installation

- Install the ionizer within 50 to 2000 mm distance to the object requiring electricity elimination. However, install the ionizer at a distance from 100 to 2000 mm when using an autobalance sensor [high-precision type or body-mounting type]. Although the ionizer can also be used at other distances, it may fail to operate normally depending on the conditions of use. Before use, always verify that the ionizer is functioning normally.

#### 3) Sensor installation

##### Autobalance sensor [High-precision type]

- When adjusting the ion balance using a high-precision type sensor, install the sensor immediately below the ionizer so that it is close to the workpiece.
- When an autobalance sensor is connected, the settings of the balance adjustment trimmer on the body are nullified.

##### Autobalance sensor [Body-mounting type]

- When adjusting the ion balance using a body-mounting type sensor, fix it to the ionizer with a bracket and then use the connection cables A and B to connect the ionizer and the sensor.
- When an autobalance sensor is connected, the settings of the balance adjustment trimmer on the body are nullified.

#### 4) Maintenance level selection switch setting

##### Autobalance sensor [High-precision type]

- Select “Manual Operation” or “Automatic Operation” when an autobalance sensor [high-precision type] is connected to adjust the ion balance.

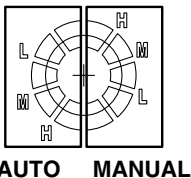

Details of operation		Switch setting
Manual operation	When a maintenance start signal is input or the ionizer is turned on, the ionizer detects electrode needle contamination according to the ion balance adjustment and the detection level settings. An ion balance adjustment value for each ion generation frequency is retained. When the ion generation frequency is changed, adjust the ion balance. After adjustment, the autobalance sensor may be removed as the ion balance adjustment will not be performed again until a maintenance start signal is input.	MANUAL
Automatic operation	The ionizer continuously adjusts the ion balance. When the autobalance sensor is removed, adjust the ion balance manually using the balance adjustment trimmer.	AUTO

\* Set the switch according to the contamination-detection level.

##### Autobalance sensor [Body-mounting type]

Configuration is not necessary.

#### 5) Ion balance adjustment

##### Autobalance sensor [High-precision type]

When an autobalance sensor is used, the ionizer automatically adjusts the ion balance to within  $\pm 30$  V.

Either “Manual Operation” or “Automatic Operation” can be selected depending on the method of ion balance adjustment.

Manual operation	When a maintenance start signal is input or the ionizer is turned on, this method adjusts the ion balance. For static electricity elimination from moving workpieces, “Manual Operation” is recommended. Start system operation after ion balance adjustment is completed.
Automatic operation	This method continuously adjusts the ion balance. For static electricity elimination from stationary workpieces or spatial static electricity elimination, “Automatic Operation” is recommended.

##### Autobalance sensor [Body-mounting type]

Controls the initial ion balance.

When changing the ion balance settings, use a balance adjustment trimmer on the autobalance sensor (requires a separate measuring instrument to verify the ion balance).

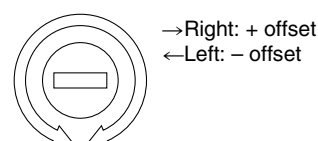

A balance adjustment trimmer is turned two full turns.



## Model Selection and Settings 2 / Pulse DC Mode

### ■ When a sensor is not used.

When an autobalance sensor is not used, set the switch to AUTO. Then, adjust the ion balance manually using the balance adjustment trimmer on the body.

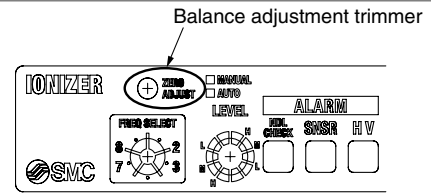

- Configuration of contamination-detection level on an electrode needle.
- Set the switch to either H (High), M (Middle), L (Low). At settings other than these, the ionizer does not perform the electrode needle contamination-detection.

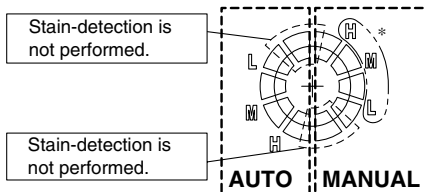

H (High).....Level that does not affect the discharge time.  
 M (Middle).....Level at which the discharge time is a little bit longer than it was initially.  
 L (Low).....Level at which the discharge time is longer than it was initially.

\* When an autobalance sensor is used, select the switch based on the operation mode.  
 Example: When adjusting the ion balance in the manual operation mode using an autobalance sensor, select a maintenance level of H, M, L on the MANUAL side.

- Contamination-detection starts when a maintenance start signal is input.
- When the switch is set to H, M, L, the ionizer performs the electrode needle contamination-detection and then the ion balance adjustment.

### 6) Frequency selection switch setting

- Select the ion generation frequency.

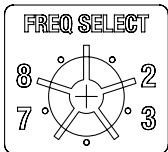

Ion generation frequency	Switch setting
1 Hz	0
3 Hz	1
5 Hz	2
10 Hz	3
15 Hz	4
20 Hz	5
30 Hz	6
60 Hz	7

### 7) Wiring of the power supply cable

- Connect the dedicated power supply cable.

#### ■ Connection with ionizer driving

Symbol	Cable color	Description	Connection needs		Contents
			High-precision type	Body-mounting type	
DC1(+)	Brown	Power supply 24VDC	○	—	Ionizer driving power supply cable
DC1(-)	Blue	Power supply GND [FG]*	○	○ [FG]	
OUT4	Dark green	Sensor monitor output	—	—	—

\* When a high-precision type sensor is used, connect DC1 (-) [Blue] to the power supply GND and be sure to ground according to Class-D. If the lead is not grounded, the ionizer may malfunction.

\* When a body-mounting type sensor is used, do not connect DC1 (-) [Blue] to the power supply GND and be sure to ground according to Class-D. In case of connecting the lead to the power supply GND and grounding according to Class-D, all I/O signals are not insulated from the FG terminal.

### ⚠ Caution

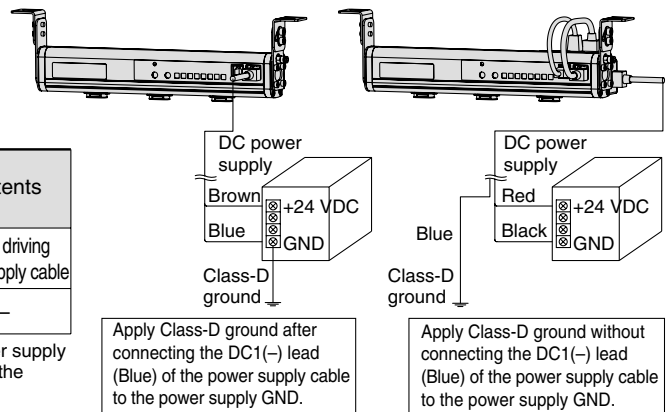

**Autobalance sensor [High-precision type]**

**Autobalance sensor [Body-mounting type]**

#### ■ Connection with input/output signal power supply cable

Symbol	Cable colour	Description	Connection needs		Contents
			High-precision type	Body-mounting type	
DC2 (+)	Red	Power supply 24 VDC	○	○	Input/Output signal power supply cable
DC2 (-)	Black	Power supply GND	○	○	
IN1	Light green	Discharge stop signal	○	○	Signal for enabling/disabling discharge (NPN spec.) Discharge is enabled when connected to DC2 (-) [Black]. (PNP spec.) Discharge is enabled when connected to DC2 (+) [Red].
IN2	Grey	Maintenance start signal	△	△	Input signal when determining the necessity of electrode needle maintenance
—	White	—	—	—	—
—	Orange	—	—	—	—
OUT1	Pink	Static electricity elimination completion signal	△	△	Turned ON when the electrode needle contamination-detection is in progress.
OUT2	Yellow	Maintenance output signal	△	△	Turned ON when electrode needle maintenance is necessary.
OUT3	Purple	Abnormal signal	△	△	Turned ON in case of high-voltage error, sensor error, CPU error. (B contact output)

○: Minimum wiring requirement for ionizer operation

△: Wiring necessary to use various functions

—: Wiring not required in the sensing DC mode. Ensure that this wire does not short-circuit to other wires.

## Model Selection and Settings 2 / Pulse DC Mode

### 8) Air piping

- For single-side piping, block the unused port with the M-5P plug supplied with the ionizer.

### 9) LED displays

- **POWER LED**...Indicates the state of the power input and the sensor connection.

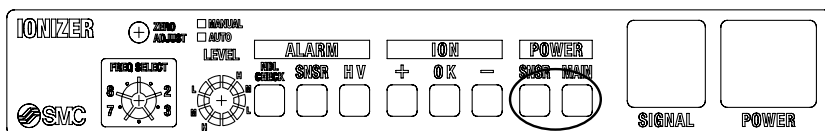

LED		Function
POWER	MAIN	Illuminates when power is supplied. (Dark green) (Blinks when the power supply is irregular.)
	SNSR	Illuminates when an autobalance sensor [high-precision type or body-mounting type] is connected. (Dark green)

- **ION LED**...Indicates the polarity of the ions being emitted and the ion balance.

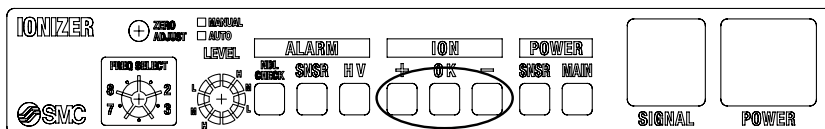

LED		Function
ION	+	Illuminates when positive ions are being emitted by the ionizer. (Orange)
	OK	When an autobalance sensor [high-precision type] is used, it indicates the state of ion balancing. (Dark green) The LED display turns OFF when a sensor is not used, or an autobalance sensor [body-mounting type] is used.
	-	Illuminates when negative ions are being emitted by the ionizer. (Blue)

- When an autobalance sensor [high-precision type] is used, the state of ion balancing can be checked by reading the LED display.

Ion balance	OK LED
Under $\pm 30$ V	Turns ON (or blinks)
$\pm 30$ V or more	Turns OFF

\* The OK LED display blinks when the ion balance is approaching the limits of the adjustable range, signaling that the time for electrode needle maintenance is approaching.

- **ALARM LED**...Indicates abnormal states of the ionizer.

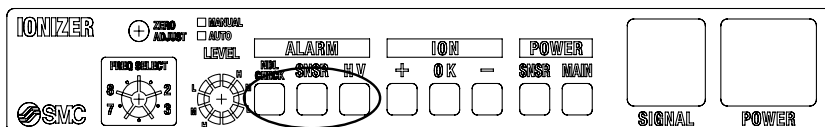

LED		Function
ALARM	HV	Illuminates when an abnormal current flows through an electrode needle. (Red)
	SNSR	Illuminates when the autobalance sensor [high-precision type] is not operating normally. (Red)
	NDL CHECK	Illuminates when electrode needle contamination is detected. (Red) (Blinks while contamination is detected.)

## Model Selection and Settings 2 / Pulse DC Mode

### 10) Alarm

Alarm item	Description	Corrective actions
High-voltage error	Occurrence of an abnormal current, such as high-voltage leakage. The ionizer stops the ion emission, turns the HV ALARM display, ON and turns the error signal (OUT3) OFF.	Turn the power OFF, solve the problem, then turn the power on again. Alternatively, turn the discharge stop signal (IN1) OFF, then ON.
Sensor error	The autobalance sensor (high-precision type or body-mounting type) has become unable to operate normally. The ionizer stops the ion emission, turns the SNSR ALARM display ON, and turns the error signal (OUT3) OFF.	Turn the power OFF, solve the problem, then turn the power on again. Alternatively, turn the discharge stop signal (IN1) OFF, then ON.
CPU error	Occurrence of a failure in the CPU due to noise, etc. The ionizer stops the ion emission, all of the LED displays blink, and turns the error signal (OUT3) OFF.	Turn the power OFF, solve the problem, then turn the power on again. Alternatively, turn the discharge stop signal (IN1) OFF, then ON.
Electrode needle maintenance	Electrode needle maintenance is necessary. The NDL CHECK ALARM display comes on and a maintenance output signal (OUT2) turns ON.	Turn the power OFF, clean or replace the electrode needles, and turn the power on again.

### 11) Timing chart

#### ■ Timing chart in normal operation

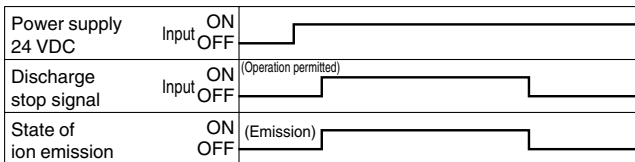

#### ■ Timing chart when electrode needle contamination or ion balance is detected.

##### (a) When an autobalance sensor [high-precision type] is connected.

###### (1) Manual operation

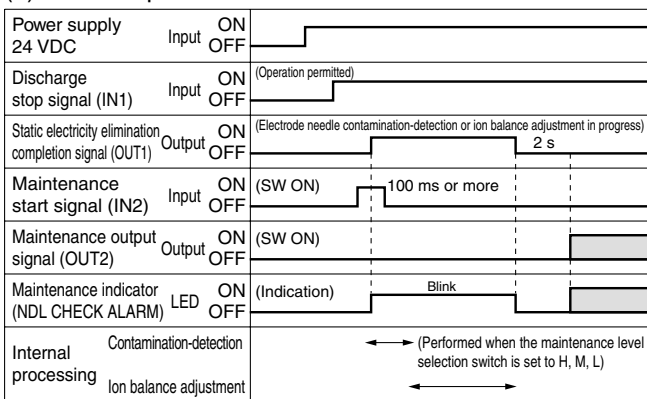

###### (2) Automatic operation

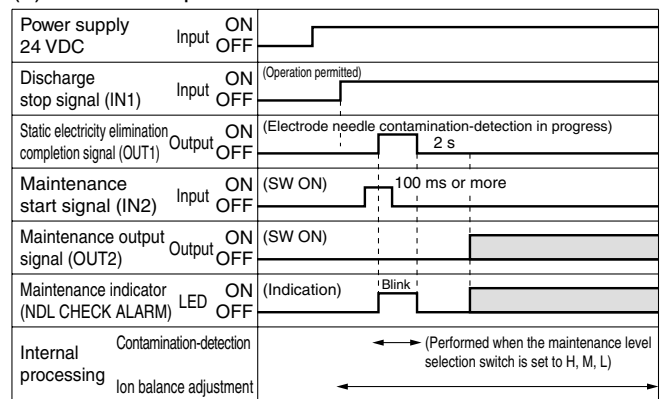

##### (b) When an autobalance sensor [body-mounting type] is connected.

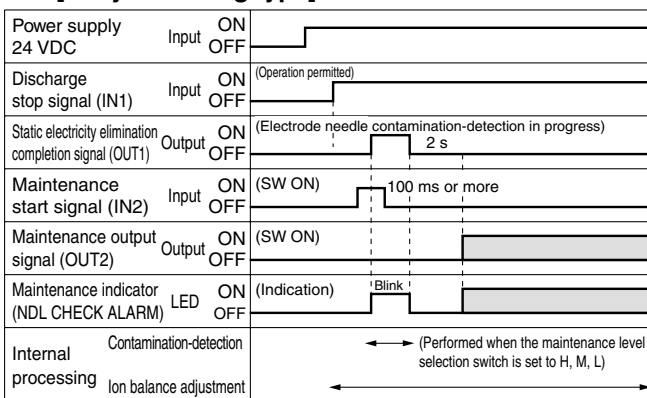

##### (c) When a sensor is not connected.

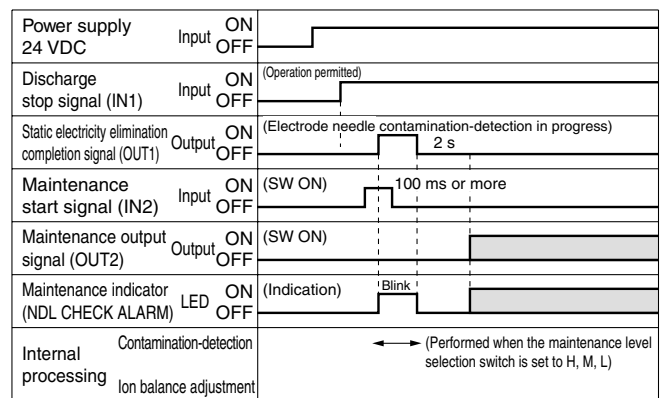

■: Either ON or OFF depending on the situation

· Static electricity elimination completion is turned on when the electrode needle contamination-detection is in progress.

### ⚠ Caution

Ions are emitted from the ionizer to detect electrode needle contamination, so the workpiece may, therefore, be electrostatically charged. Perform this detection procedure in the absence of workpieces.

## Model Selection and Settings 3 / DC Mode

### 3. DC mode

#### 1) Bar length selection

- Select the appropriate length suited for a workpiece size by referring to “Static Electricity Elimination Characteristics” and “Static Electricity Elimination Range”, etc.

#### 2) Ionizer installation

- Install the ionizer within 50 to 2000 mm distance to the object requiring electricity elimination. Although the ionizer can also be used at other distances, it may fail to operate normally depending on the conditions of use. Before use, always verify that the ionizer is functioning normally.

#### 3) Frequency selection switch setting

- Select “Positive Ion Emission” or “Negative Ion Emission”.

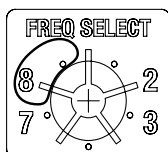

Ion polarity	Switch setting
Positive ion emission	8
Negative ion emission	9

#### 4) Wiring of the power supply cable

- Connect the dedicated power supply cable.

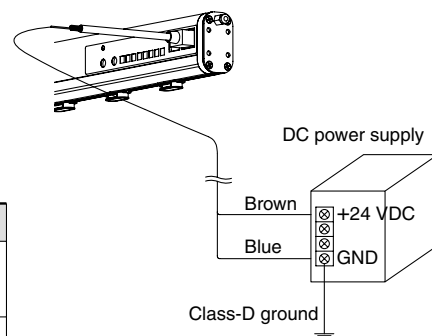

#### ■ Connection with ionizer driving power supply

Symbol	Cable colour	Description	Connection needs	Contents
DC1 (+)	Brown	Power supply 24 VDC	○	Ionizer driving power supply cable
DC1 (-)	Blue	Power supply GND [FG]	○	
OUT4	Dark green	Sensor monitor output	—	—

\* DC1 (-) [Blue] may be grounded according to Class-D. If the terminal is not grounded, the ionizer may malfunction.

#### ■ Connection with input/output signal power supply

Symbol	Cable colour	Description	Connection needs	Contents
DC2(+)	Red	Power supply 24 VDC	○	Input/Output signal power supply cable
DC2(-)	Black	Power supply GND	○	
IN1	Light green	Discharge stop signal	○	Signal for enabling/disabling discharge (NPN spec.) Discharge is enabled when connected to DC2 (-) [Black]. (PNP spec.) Discharge is enabled when connected to DC2 (+) [Red].
IN2	Grey	Maintenance start signal	—	—
—	White	—	—	—
—	Orange	—	—	—
OUT1	Pink	Static electricity elimination completion signal	—	—
OUT2	Yellow	Maintenance output signal	—	—
OUT3	Purple	Abnormal signal	△	Turned ON in normal operation. Turned OFF in case of high-voltage error, CPU error.

○ : Minimum wiring requirement for ionizer operation

△ : Wiring necessary to use various functions

— : Wiring not required in the sensing DC mode. Ensure that this wire does not short-circuit to other wires.

#### 5) Air piping

- For single-side piping, block the unused port with the plug (M-5P-X112) supplied with the ionizer.

## Model Selection and Settings 3 / DC Mode

### 6) LED displays

■ **POWER LED**...Indicates the state of the power input and the sensor connection.

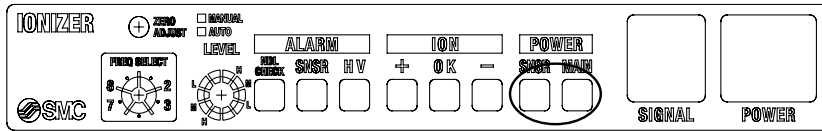

LED		Function
POWER	MAIN	Illuminates when power is supplied. (Dark green) (Blinks when the power supply is irregular.)
	SNSR	Light OFF

■ **ION LED**...Indicates the polarity of the ions being emitted.

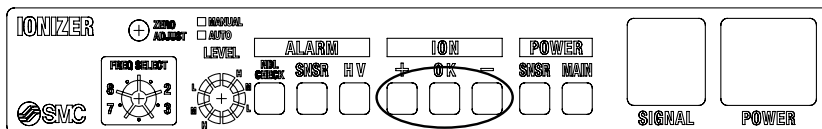

LED		Function
ION	+	Illuminates when positive ions are emitted by the ionizer. (Orange)
	OK	Light OFF
	-	Illuminates when negative ions are emitted by the ionizer. (Blue)

■ **ALARM LED**...Indicates abnormal states of the ionizer.

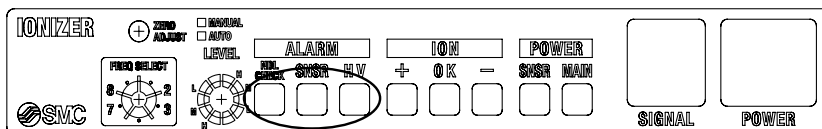

LED		Function
ALARM	HV	Illuminates when an abnormal current flows through the electrode needle. (Red)
	SNSR	Light OFF
	NDL CHECK	Light OFF

### 7) Alarm

Alarm item	Description	Corrective actions
High-voltage error	Occurrence of an abnormal current, such as high-voltage leakage. The ionizer stops ion emission, turns the HV ALARM display, ON and turns an error signal (OUT3) OFF.	Turn the power OFF, solve the problem, then turn the power ON again. Alternatively, turn the discharge stop signal (IN1) OFF, then ON.
CPU error	Occurrence of a failure in the CPU due to noise, etc. The ionizer stops ion emission, all of the LED displays blink, and turns an error signal (OUT3) OFF.	Turn the power OFF, solve the problem, then turn the power ON again. Alternatively, turn the discharge stop signal (IN1) OFF, then ON.

### 8) Timing chart

■ **Timing chart in normal operation**

Power supply 24 VDC	Input	ON OFF	
Discharge stop signal (IN1)	Input	ON OFF	
State of ion emission		ON OFF	

## Circuit of Power Cable Connection

(1) When a sensor is not used. / When a feedback sensor or autobalance sensor [high-precision type] is used.

### NPN output

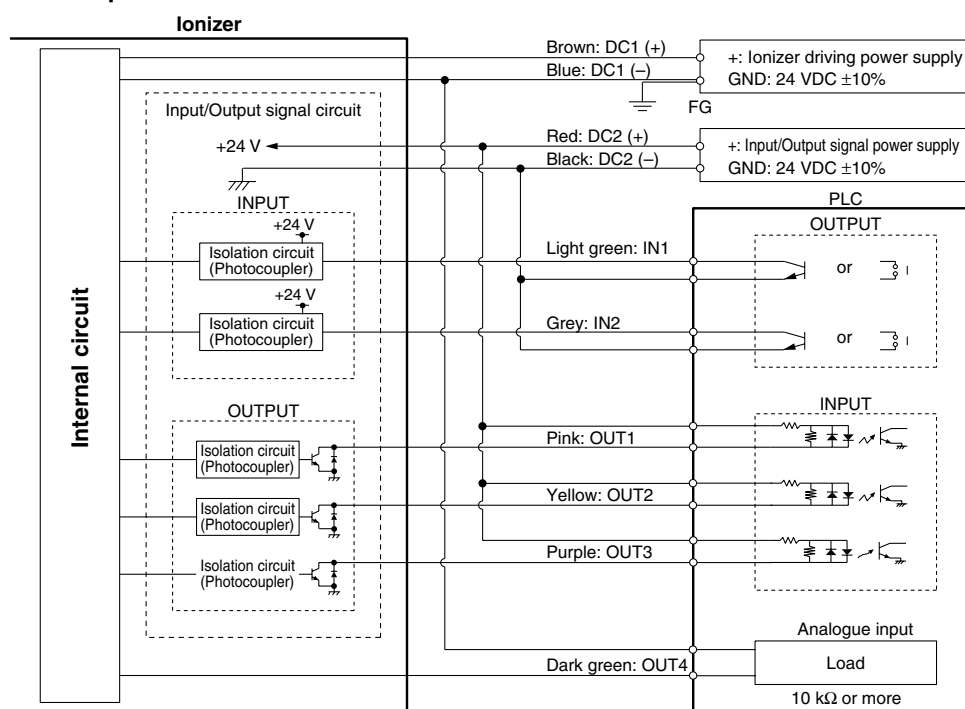

### PNP output

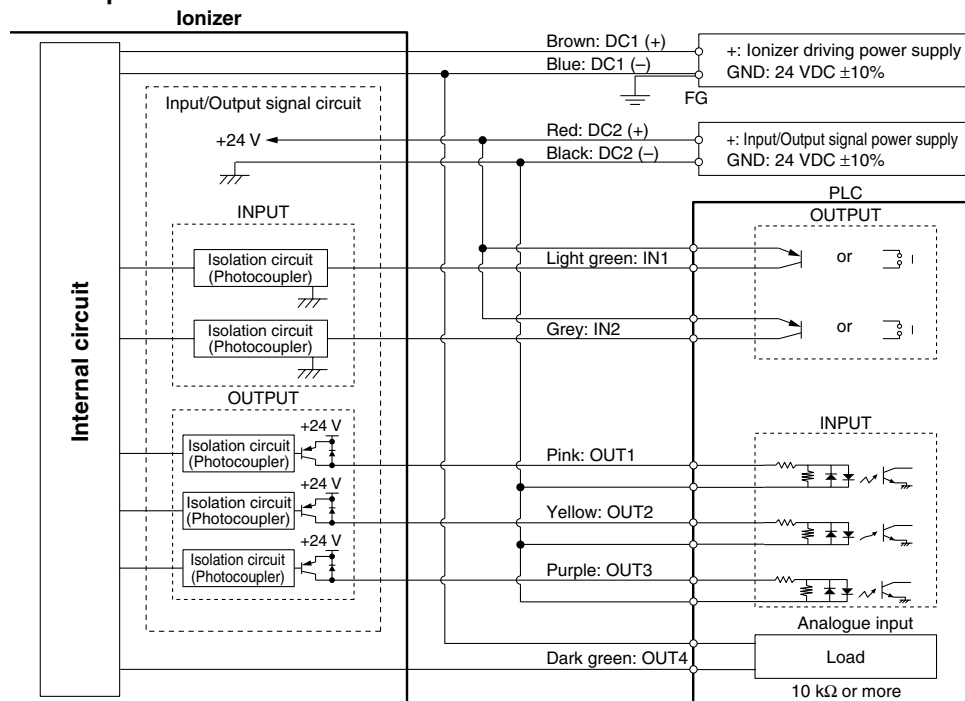

Apply Class-D grounding to the GND terminal of the ionizer driving power supply by connecting the lead DC (-) [Blue] to the FG terminal. The leads for output signals (OUT1 to OUT3) are insulated from the insulation circuit (Photocoupler), while the sensor monitor output lead\* (OUT4: Dark green) is not insulated from the FG terminal.

\* Sensor monitor output lead (OUT4: Dark green) When the feedback sensor is used, the terminal outputs the potential measured by the feedback sensor as an analogue signal. When the autobalance sensor is used, the terminal does not output signals.

The lead of the ionizer driving power supply (DC1) and the lead of the power supply for I/O signals (DC2) can be connected with a common power supply. When a common power supply is used, the lead DC1 (-) with Class-D grounded and leads for I/O signals are not insulated.



## Circuit of Power Cable Connection

(2) When an autobalance sensor [body-mounting type] is used.

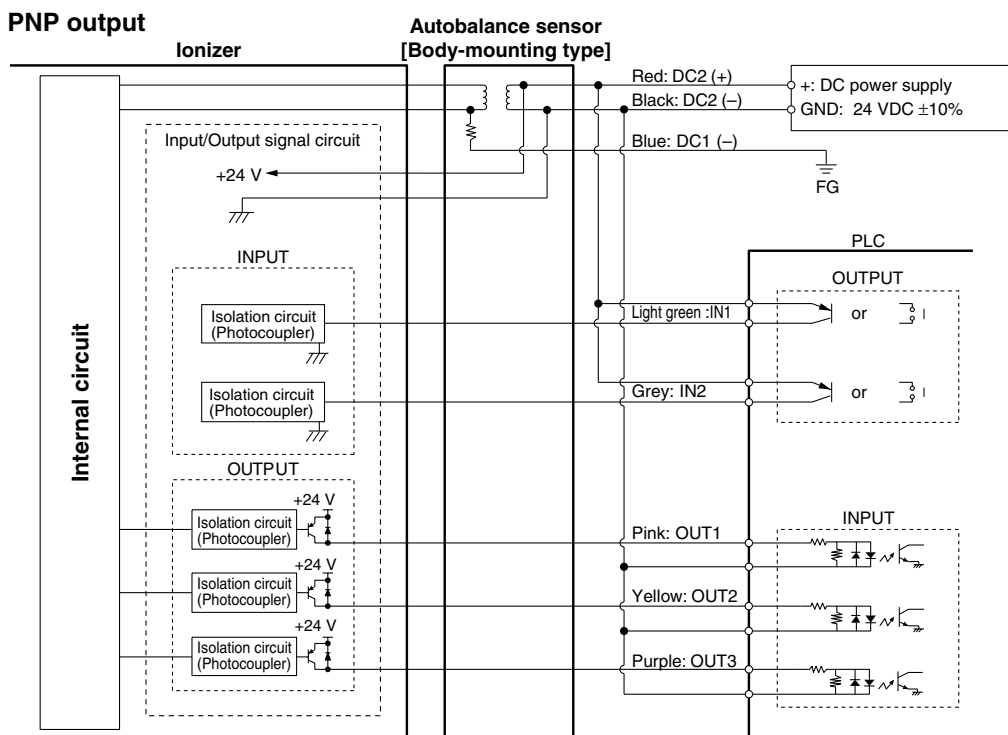
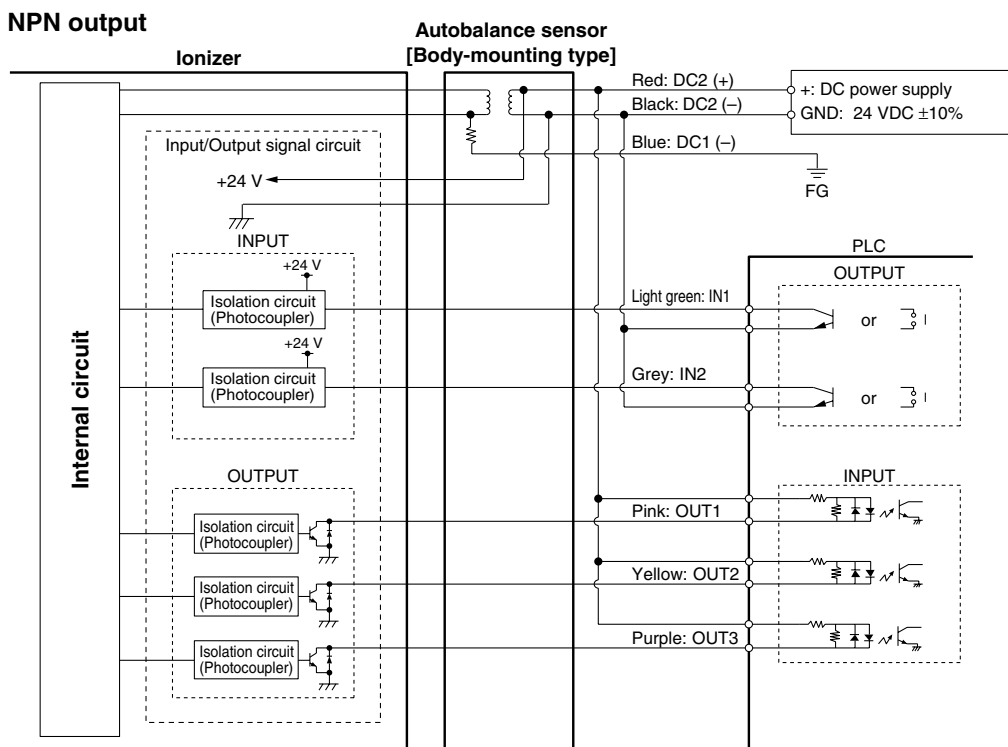

\* Apply Class-D grounding to the lead DC (-) [Blue], and do not connect to the GND terminal of the power supply. When the lead is connected to the GND terminal of the power supply and Class-D grounding is applied, leads for I/O signals are not insulated from the FG terminal.

### ⚠ Caution

When using the autobalance sensor (body-mounting type) near the ionizer in DC mode, keep clearance of at least 2 m between them.

\* If the clearance is not enough, the ions from the ionizer in DC mode affect the control of the autobalance sensor, thus resulting in imbalance of ions.

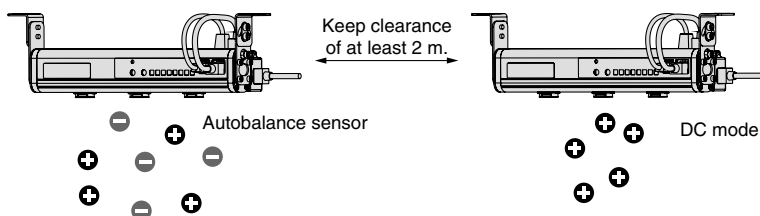

# Series IZS31

## Dimensions

Ionizer / IZS31-□□□□-□□

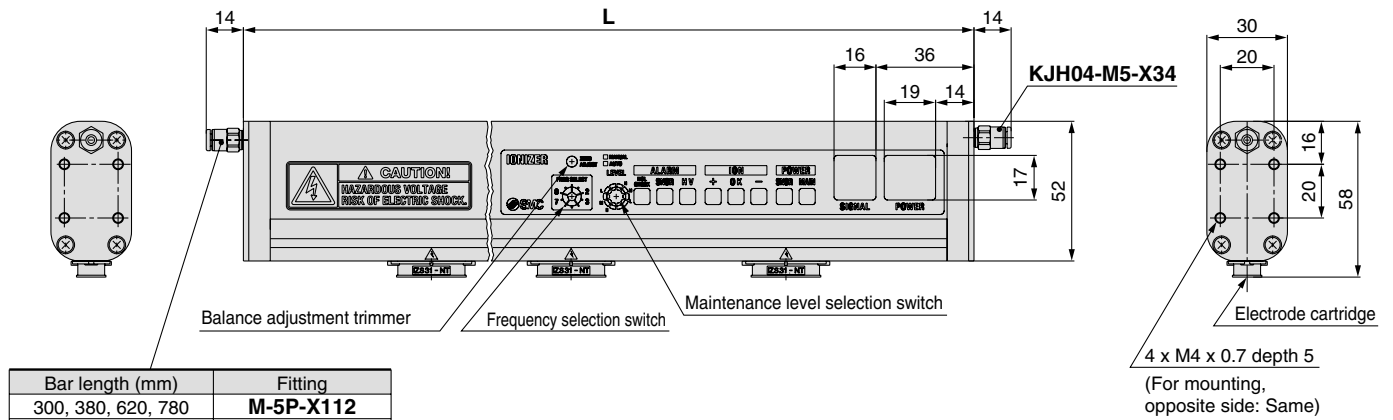

Note) Plug (M-5P-X112) 1 pc. is shipped together.

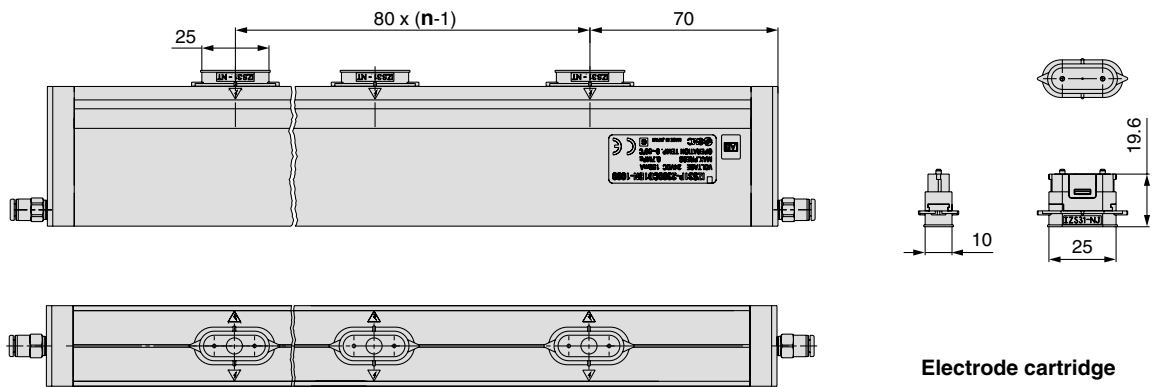

Electrode cartridge

n (Number of electrode cartridges),  
L Dimension

Part no.	n	L(mm)
<b>IZS31-300</b>	3	300
<b>IZS31-380</b>	4	380
<b>IZS31-620</b>	7	620
<b>IZS31-780</b>	9	780
<b>IZS31-1100</b>	13	1100
<b>IZS31-1260</b>	15	1260
<b>IZS31-1500</b>	18	1500
<b>IZS31-1900</b>	23	1900
<b>IZS31-2300</b>	28	2300

**Dimensions**

**End bracket / IZS31-BE**

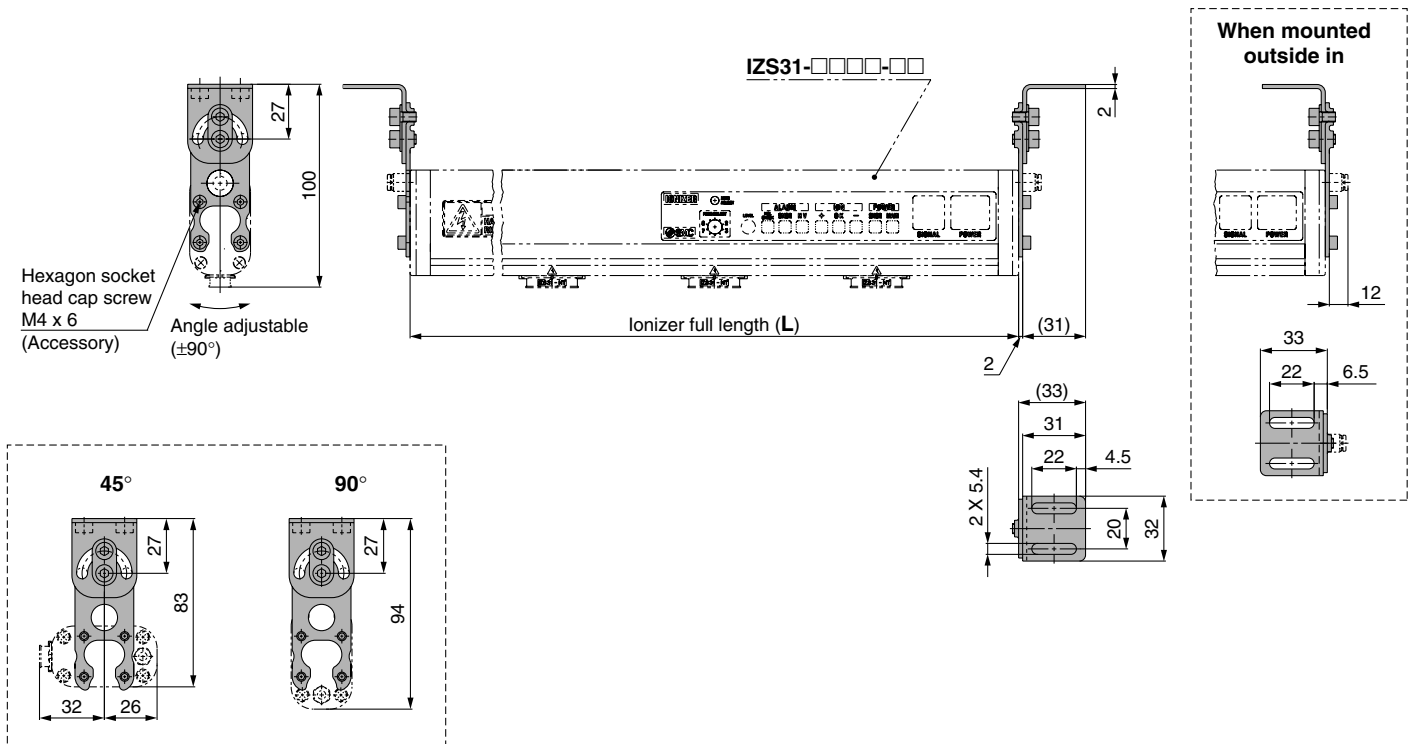

**Center bracket / IZS31-BM**

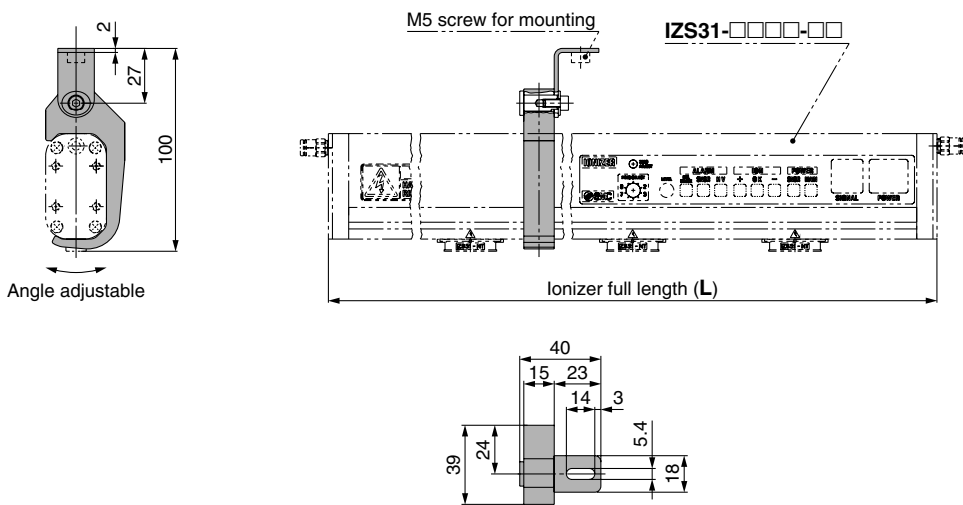

Note) Number of center brackets included in a model with brackets. (Refer to "How to Order" in page 5.)

Bar length (mm)	Center bracket
300, 380, 620, 780	None
1100, 1260, 1500	With 1 pc.
1900, 2300	With 2 pcs.

# Series IZS31

## Dimensions

### Feedback sensor / IZS31-DF

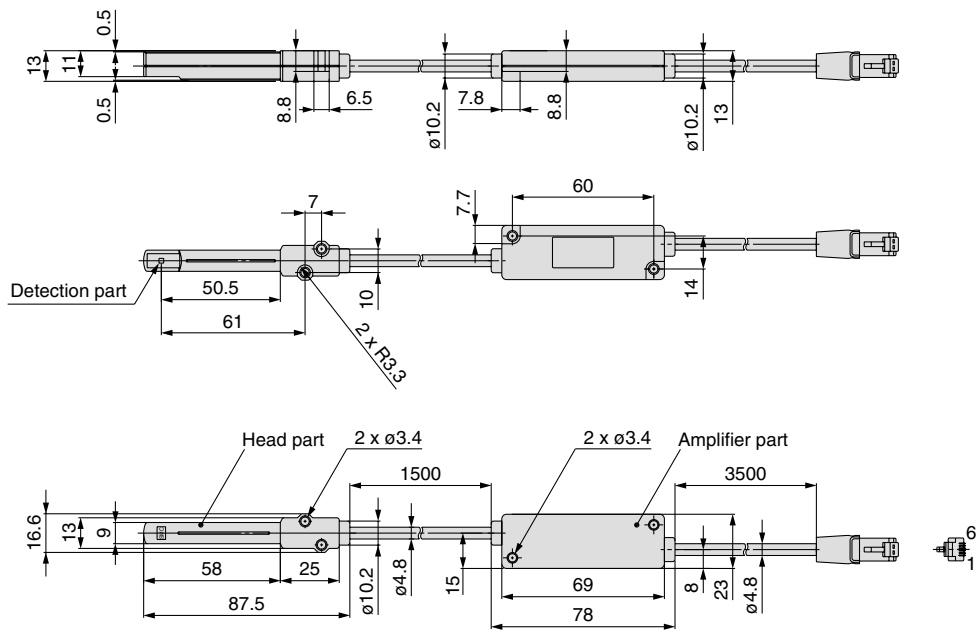

### Autobalance sensor [High-precision type] / IZS31-DG

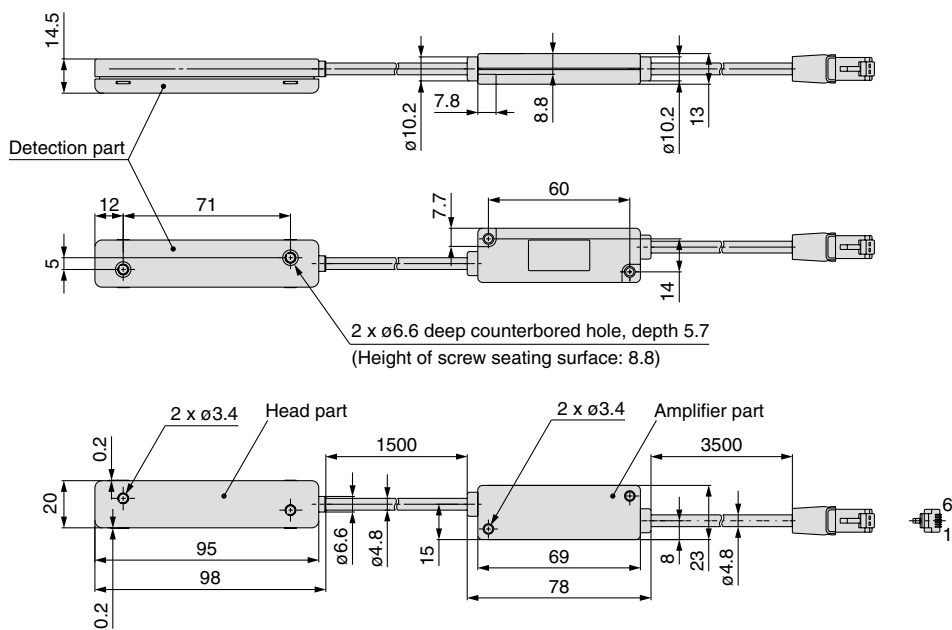

### Power supply cable / IZS31-CP□

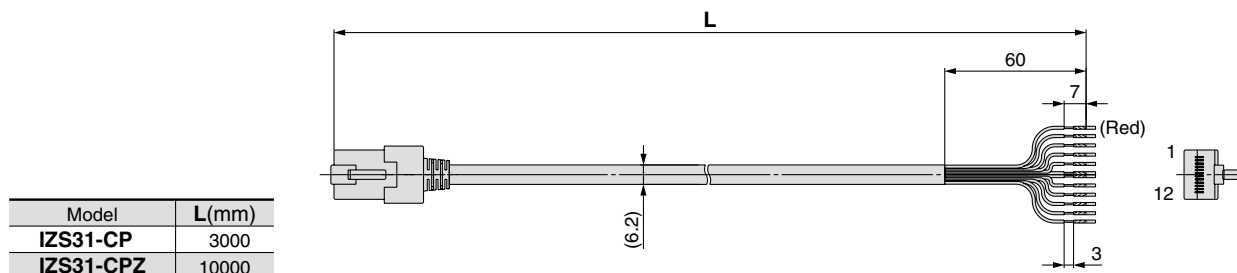

## Dimensions

### Autobalance sensor [Body-mounting type] / IZS31-DE

#### When mounting on the ionizer

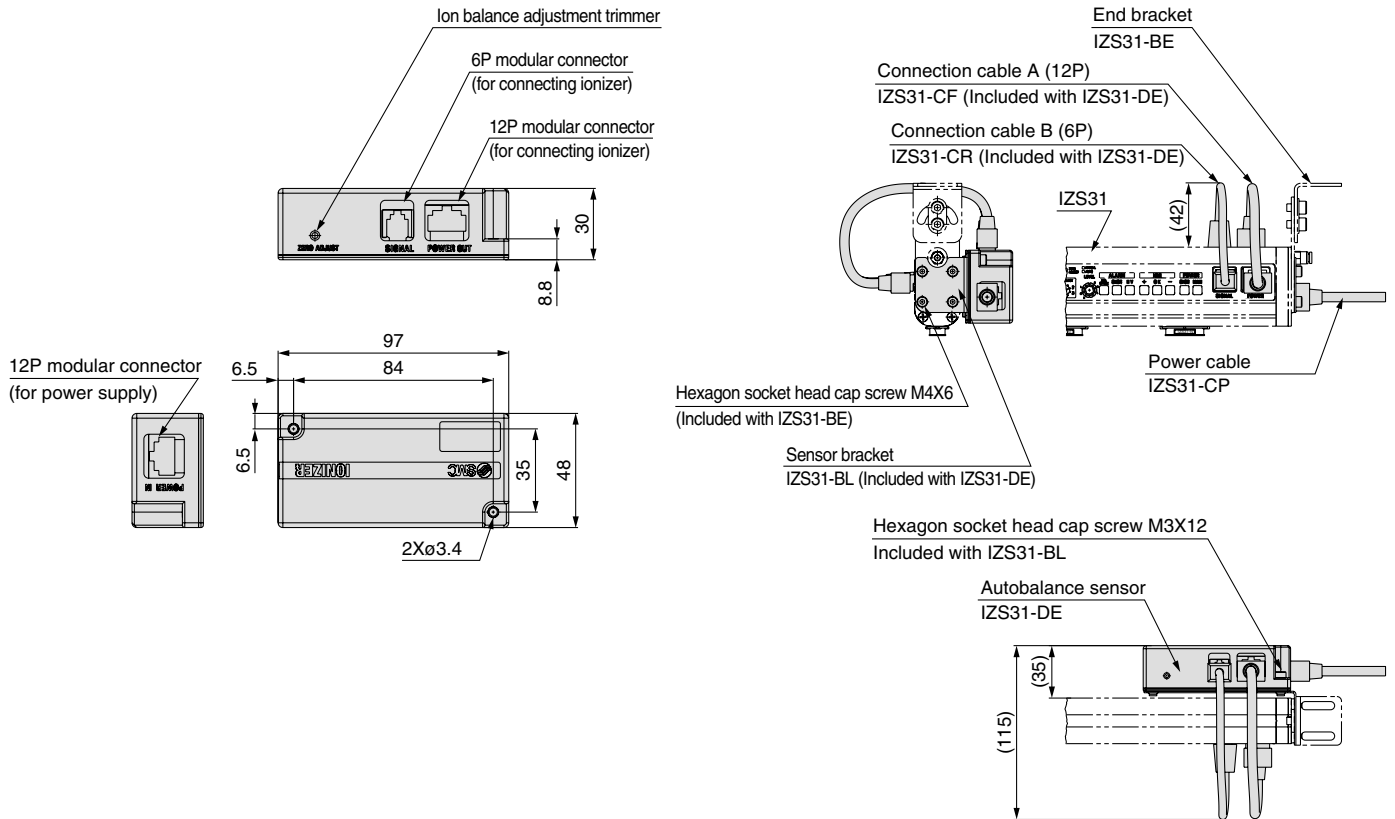

### Connection cable A (12P) / IZS31-CF

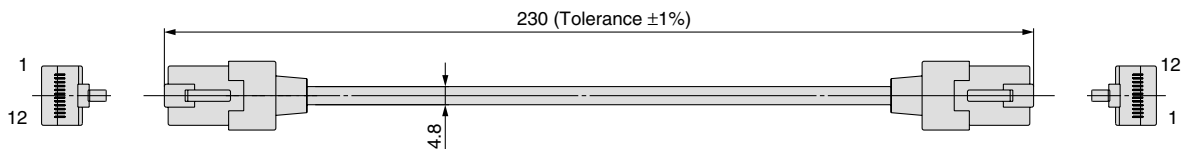

### Connection cable B (6P) / IZS31-CR

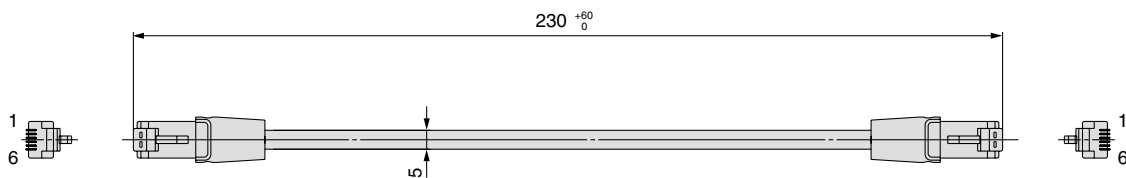

### Sensor bracket / IZS31-BL

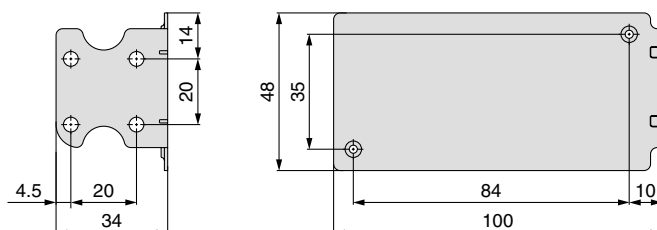

# Series IZS31 Made to Order 1

For detailed dimensions, specifications and delivery time, please contact SMC.



## 1 Non-standard bar length (80 mm-pitch)

Symbol  
**X10**

\*Refer to "How to Order" in page 5.

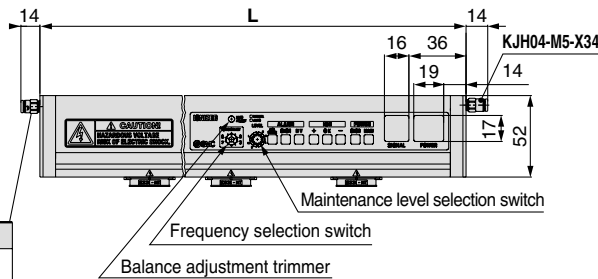
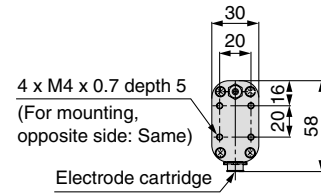
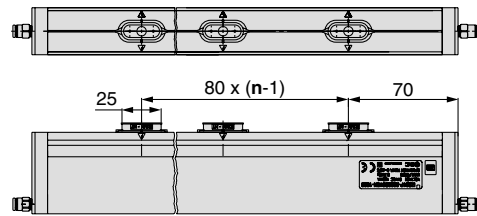

Bar length (mm)	Fitting
460, 540, 700	<b>M-5P-X112</b>
860, 940, 1020, 1180, 1340, 1420, 1580, 1660, 1740, 1820, 1980, 2060, 2140, 2220	<b>KJH04-M5-X34</b> <small>(Note)</small>

Note) Plug (M-5P-X112) 1 pc. is shipped together.

### n (Number of electrode cartridges), L Dimension, Weight

Part no.	n	L (mm)	Weight (g)
IZS31-460□□□-□□-X10	5	460	600
IZS31-540□□□-□□-X10	6	540	660
IZS31-700□□□-□□-X10	8	700	780
IZS31-860□□□-□□-X10	10	860	910
IZS31-940□□□-□□-X10	11	940	970
IZS31-1020□□□-□□-X10	12	1020	1040
IZS31-1180□□□-□□-X10	14	1180	1160
IZS31-1340□□□-□□-X10	16	1340	1290
IZS31-1420□□□-□□-X10	17	1420	1350
IZS31-1580□□□-□□-X10	19	1580	1480
IZS31-1660□□□-□□-X10	20	1660	1540
IZS31-1740□□□-□□-X10	21	1740	1600
IZS31-1820□□□-□□-X10	22	1820	1660
IZS31-1980□□□-□□-X10	24	1980	1790
IZS31-2060□□□-□□-X10	25	2060	1850
IZS31-2140□□□-□□-X10	26	2140	1920
IZS31-2220□□□-□□-X10	27	2220	1980

### Number of Center Brackets

Bar length (mm)	Quantity
460 to 700	None
860 to 1580	With 1 pc.
1660 to 2220	With 2 pcs.

## 2 Non-standard power supply cable length

Symbol  
**X13**

Available in 1 m increments from 1 m to 20 m.

Note 1) 11 m or longer power cables are not CE Marking-compliant.

Note 2) Use standard power cables for 3 m and 10 m lengths.

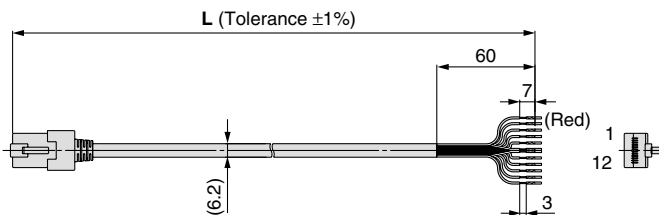

### How to Order

# IZS31 - CP □ - X13

#### Cable length

Symbol	L: Cable length
01	1000 mm
02	2000 mm
04	4000 mm
05	5000 mm
06	6000 mm
07	7000 mm
08	8000 mm
09	9000 mm
11	11000 mm
12	12000 mm
13	13000 mm
14	14000 mm
15	15000 mm
16	16000 mm
17	17000 mm
18	18000 mm
19	19000 mm
20	20000 mm

# Series IZS31

## Made to Order 2

For detailed dimensions, specifications and delivery time, please contact SMC.



### 3 Model with 40 mm-pitch electrode cartridges

Symbol  
**X15**

Install the electrode cartridges at a 40 mm-pitch.  
(Standard: 80 mm-pitch)

Note) The maximum bar length is 1260 mm.

The air purge nozzles are arranged at an 80 mm-pitch.

- Uneven static electricity elimination can be prevented when the installation height is low.

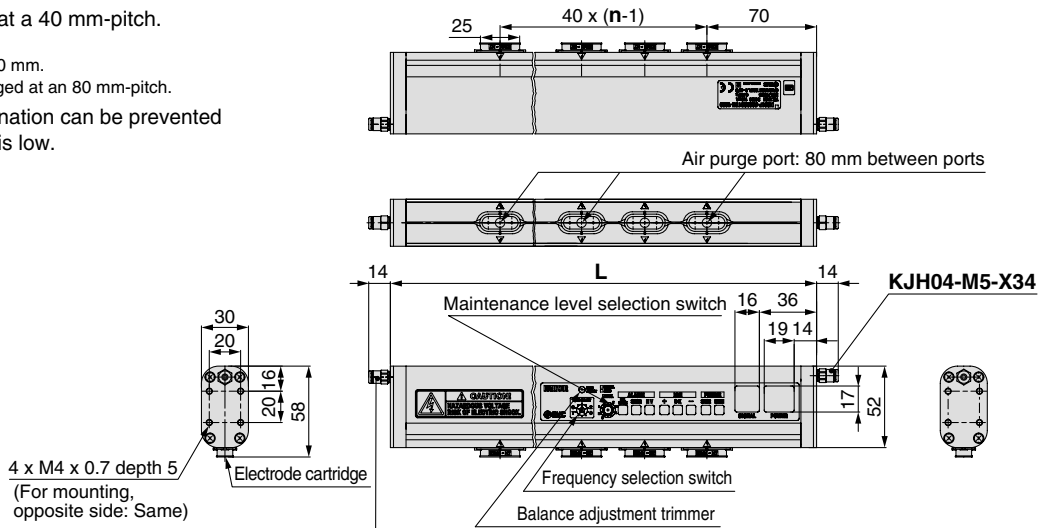

4 x M4 x 0.7 depth 5  
(For mounting, opposite side: Same)

Bar length (mm)	Fitting
300, 380, 620, 780	M-5P-X112
1100, 1260	KJH04-M5-X34

Note) Plug (M-5P-X112) 1 pc. is shipped together.

n (Number of electrode cartridges),  
L Dimension, Weight

Part no.	n	L(mm)	Weight (g)
IZS31-300□□□-□□-X15	5	300	480
IZS31-380□□□-□□-X15	7	380	540
IZS31-620□□□-□□-X15	13	620	740
IZS31-780□□□-□□-X15	17	780	880
IZS31-1100□□□-□□-X15	25	1100	1140
IZS31-1260□□□-□□-X15	29	1260	1270

### Center bracket / IZS31-BM-X158

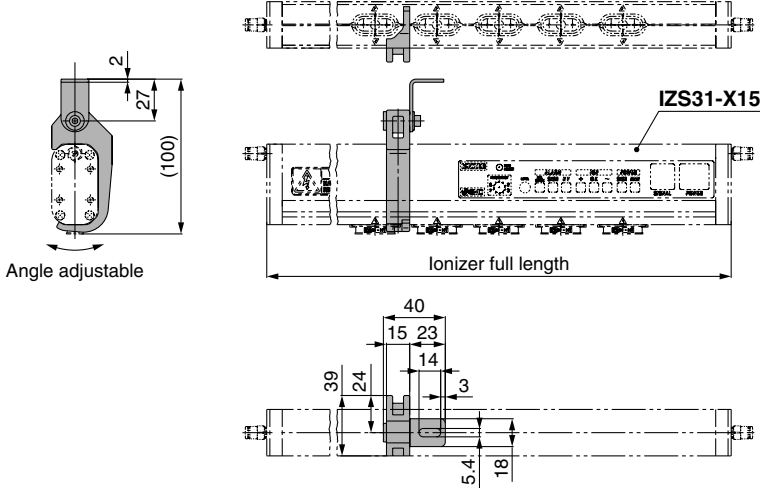

Note) Number of center brackets included in a model with brackets. (Refer to "How to Order" in page 5.)

Bar length (mm)	Center bracket
300, 380, 620, 780	None
1100, 1260	With 1 pc.

### 4 Ionizer driving AC adapter (100 to 240 VAC)

Symbol  
**X196EU**

The ionizer operation is possible if the power plug is connected to the AC power supply (100 to 240 V)

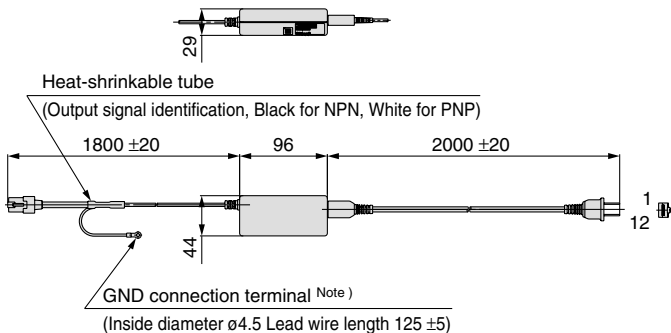

Note: Be sure to apply Class-D grounding to the GND terminal.

### How to Order

IZS31 - F □ - X196EU

● Applicable output spec

—	NPN specification
P	PNP specification

### Specifications

Input voltage	100 VAC to 240 VAC, 50/60 Hz
Output voltage	24 VDC
Output current	1A
Ambient temperature	0 to 40°C
Ambient humidity	35 to 65% Rh
Weight	220 g



# Series IZS31

## Made to Order 3

For detailed dimensions, specifications and delivery time, please contact SMC.



### 5 High-voltage/control unit detachable short type

Symbol  
**X210**

- A short type ionizer (full length of 180 mm and 220 mm) can be installed in a small space. The high-voltage unit (ionizing unit) and control unit are detachable from each other. The distance between them is also optional according to the length of the selected connection cables.

Part no.	L
IZS31-CF01-X210	1000 mm
IZS31-CF02-X210	2000 mm
IZS31-CF03-X210	3000 mm
IZS31-CF04-X210	4000 mm
IZS31-CF05-X210	5000 mm
IZS31-CF07-X210	7000 mm
IZS31-CF10-X210	10000 mm

Order connection cables separately.

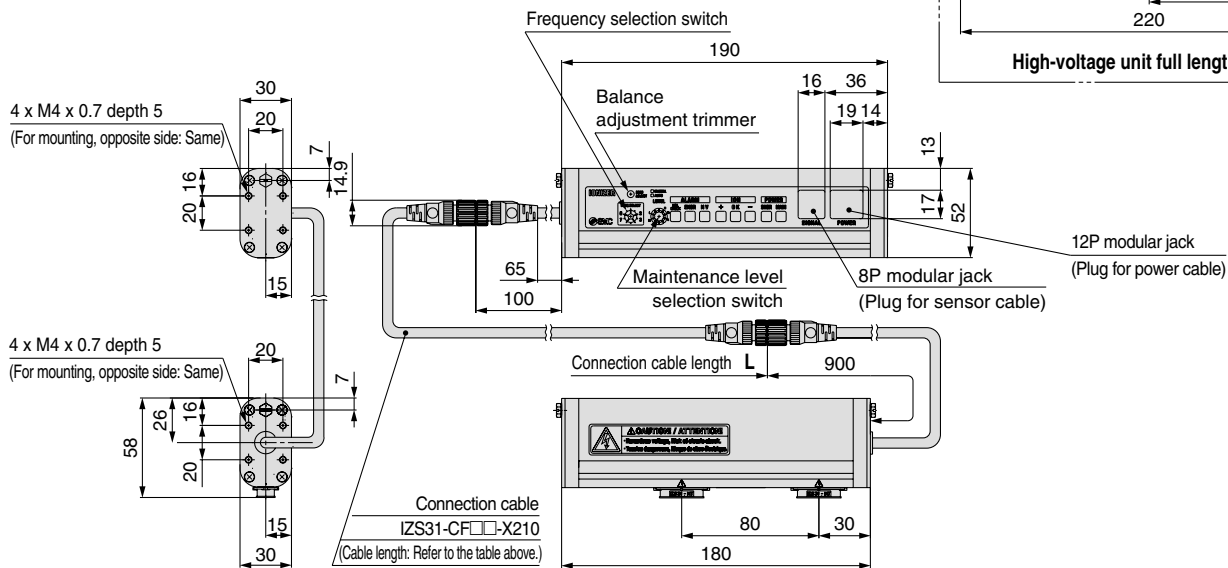
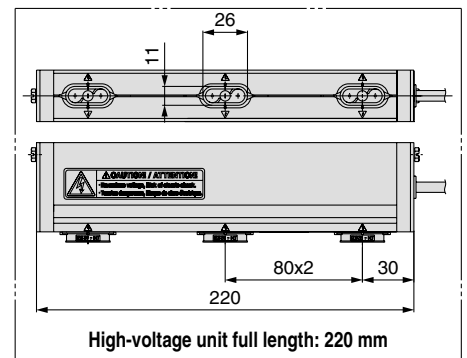
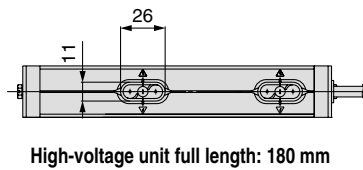
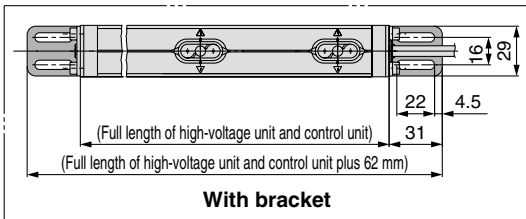
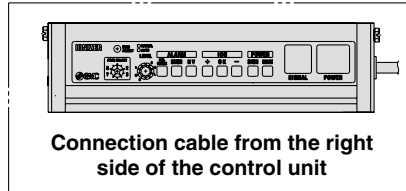

### How to Order

**IZS31 - 180** **R** **- X210**

High-voltage unit full length

180	180 mm
220	220 mm

Electrode needle material

—	Tungsten
C	Silicon
S	Stainless steel
J	Low-maintenance type / Tungsten
K	Low-maintenance type / Silicon

Output specification

—	NPN output
P	PNP output

Control unit cable entry direction

—	Left-side entry
R	Right-side entry

Bracket

—	Without bracket
B	With bracket (Note)

Note) Four end brackets are bundled with the bracket model. Brackets can be attached on the high-voltage unit and control unit.

Power cable

—	With power cable (3 m)
Z	With power cable (10 m)
N	Without power cable

Sensor

—	Without sensor
E	Autobalance sensor [Body-mounting type]
F	Feedback sensor
G	Autobalance sensor [High-precision type]

# Series IZS31

## Made to Order 4

For detailed dimensions, specifications and delivery time, please contact SMC.



### 6 High-voltage/control unit detachable short type with 40 mm-pitch electrode cartridges

Symbol **X211**

- A short type ionizer (full length of 180 mm and 220 mm) can be installed in a small space. The high-voltage unit (ionizing unit) and control unit are detachable from each other. The distance between them is also optional according to the length of selected connection cables. Model with 40 mm-pitch electrode cartridges

Part no.	L
IZS31-CF01-X210	1000 mm
IZS31-CF02-X210	2000 mm
IZS31-CF03-X210	3000 mm
IZS31-CF04-X210	4000 mm
IZS31-CF05-X210	5000 mm
IZS31-CF07-X210	7000 mm
IZS31-CF10-X210	10000 mm

Order connection cables separately.

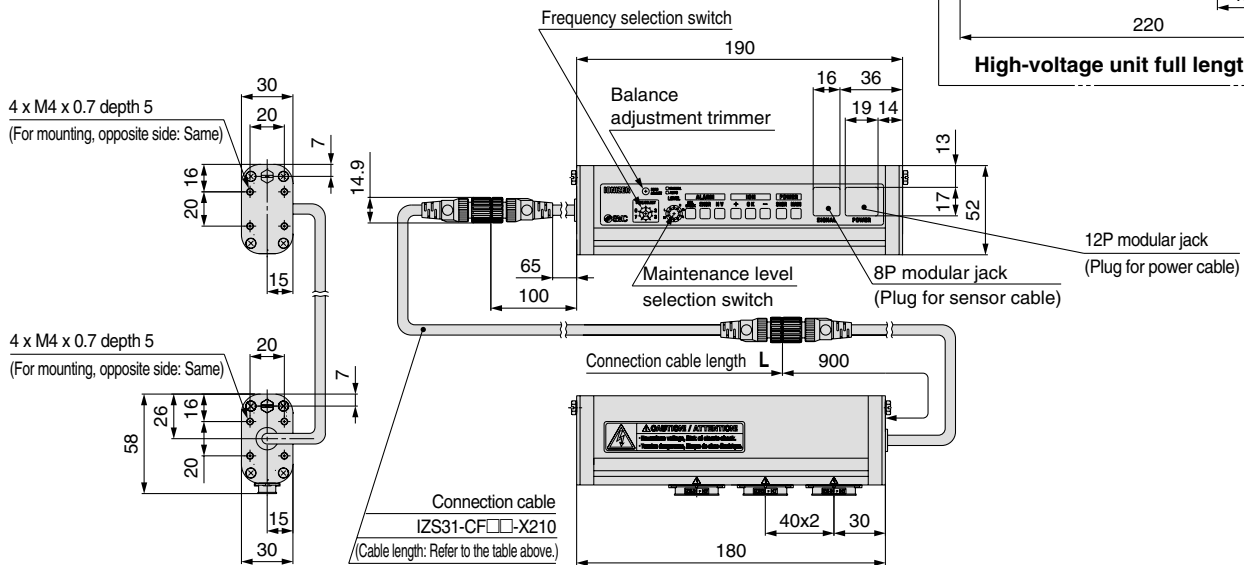
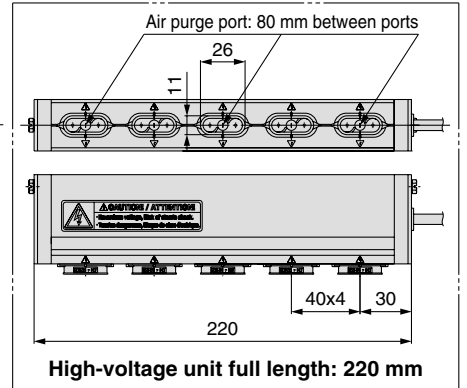
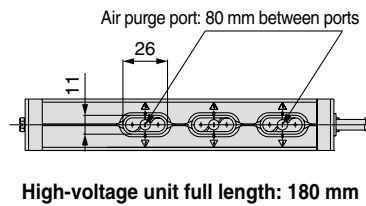
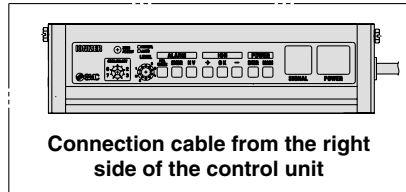
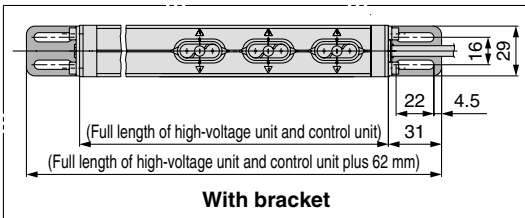

### How to Order

## IZS31 - 180 [ ] [ ] R [ ] [ ] - X211

<b>High-voltage unit full length</b>	180 180 mm	220 220 mm			
<b>Electrode needle material</b>	— Tungsten	C Silicon	S Stainless steel	J Low-maintenance type / Tungsten	K Low-maintenance type / Silicon
<b>Output specification</b>	— NPN output	P PNP output			
<b>Bracket</b>	— Without bracket	B With bracket (Note)			
<b>Power cable</b>	— With power cable (3 m)	Z With power cable (10 m)	N Without power cable		
<b>Control unit cable entry direction</b>	— Left-side entry	R Right-side entry			
<b>Sensor</b>	— Without sensor	E Autobalance sensor [Body-mounting type]	F Feedback sensor	G Autobalance sensor [High-precision type]	



Note) Four end brackets are bundled with the bracket model. Brackets can be attached on the high-voltage unit and control unit.



# Safety Instructions

These safety instructions are intended to prevent hazardous situations and/or equipment damage. These instructions indicate the level of potential hazard with the labels of “**Caution**,” “**Warning**” or “**Danger**.” They are all important notes for safety and must be followed in addition to International Standards (ISO/IEC) <sup>Note 1)</sup>, and other safety regulations.

Note 1) ISO 4414: Pneumatic fluid power – General rules relating to systems.  
ISO 4413: Hydraulic fluid power – General rules relating to systems.  
IEC 60204-1: Safety of machinery – Electrical equipment of machines. (Part 1: General requirements)  
ISO 10218-1: Manipulating industrial robots - Safety.  
etc.

-  **Caution:** **Caution** indicates a hazard with a low level of risk which, if not avoided, could result in minor or moderate injury.
-  **Warning:** **Warning** indicates a hazard with a medium level of risk which, if not avoided, could result in death or serious injury.
-  **Danger:** **Danger** indicates a hazard with a high level of risk which, if not avoided, will result in death or serious injury.

## Warning

### **1. The compatibility of the product is the responsibility of the person who designs the equipment or decides its specifications.**

Since the product specified here is used under various operating conditions, its compatibility with specific equipment must be decided by the person who designs the equipment or decides its specifications based on necessary analysis and test results. The expected performance and safety assurance of the equipment will be the responsibility of the person who has determined its compatibility with the product. This person should also continuously review all specifications of the product referring to its latest catalogue information, with a view to giving due consideration to any possibility of equipment failure when configuring the equipment.

### **2. Only personnel with appropriate training should operate machinery and equipment.**

The product specified here may become unsafe if handled incorrectly. The assembly, operation and maintenance of machines or equipment including our products must be performed by an operator who is appropriately trained and experienced.

### **3. Do not service or attempt to remove product and machinery/equipment until safety is confirmed.**

1. The inspection and maintenance of machinery/equipment should only be performed after measures to prevent falling or runaway of the driven objects have been confirmed.
2. When the product is to be removed, confirm that the safety measures as mentioned above are implemented and the power from any appropriate source is cut, and read and understand the specific product precautions of all relevant products carefully.
3. Before machinery/equipment is restarted, take measures to prevent unexpected operation and malfunction.

### **4. Contact SMC beforehand and take special consideration of safety measures if the product is to be used in any of the following conditions.**

1. Conditions and environments outside of the given specifications, or use outdoors or in a place exposed to direct sunlight.
2. Installation on equipment in conjunction with atomic energy, railways, air navigation, space, shipping, vehicles, military, medical treatment, combustion and recreation, or equipment in contact with food and beverages, emergency stop circuits, clutch and brake circuits in press applications, safety equipment or other applications unsuitable for the standard specifications described in the product catalogue.
3. An application which could have negative effects on people, property, or animals requiring special safety analysis.
4. Use in an interlock circuit, which requires the provision of double interlock for possible failure by using a mechanical protective function, and periodical checks to confirm proper operation.



# Safety Instructions

## Caution

### 1. The product is provided for use in manufacturing industries.

The product herein described is basically provided for peaceful use in manufacturing industries.

If considering using the product in other industries, consult SMC beforehand and exchange specifications or a contract if necessary.

If anything is unclear, contact your nearest sales branch.

## Limited warranty and Disclaimer/Compliance Requirements

The product used is subject to the following “Limited warranty and Disclaimer” and “Compliance Requirements”. Read and accept them before using the product.

### Limited warranty and Disclaimer

1. The warranty period of the product is 1 year in service or 1.5 years after the product is delivered.<sup>Note 2)</sup>  
Also, the product may have specified durability, running distance or replacement parts. Please consult your nearest sales branch.
2. For any failure or damage reported within the warranty period which is clearly our responsibility, a replacement product or necessary parts will be provided.  
This limited warranty applies only to our product independently, and not to any other damage incurred due to the failure of the product.
3. Prior to using SMC products, please read and understand the warranty terms and disclaimers noted in the specified catalogue for the particular products.

**Note 2) Vacuum pads are excluded from this 1 year warranty.**

A vacuum pad is a consumable part, so it is warranted for a year after it is delivered.

Also, even within the warranty period, the wear of a product due to the use of the vacuum pad or failure due to the deterioration of rubber material are not covered by the limited warranty.

### Compliance Requirements

1. The use of SMC products with production equipment for the manufacture of weapons of mass destruction (WMD) or any other weapon is strictly prohibited.
2. The exports of SMC products or technology from one country to another are governed by the relevant security laws and regulations of the countries involved in the transaction. Prior to the shipment of a SMC product to another country, assure that all local rules governing that export are known and followed.



# Series IZS31 Ionizers Precautions 1

Be sure to read this before handling.

## Selection

### Warning

- 1. This product is intended to be used with general factory automation (FA) equipment.**

If considering using the product for other applications (especially those stipulated in 4 on back page 1), please consult with SMC beforehand.

- 2. Use this product within the specified voltage and temperature range.**

Using within a voltage range other than specified can cause malfunction, damage, electrical shock, or fire.

- 3. Use clean compressed air for fluid.**

This product is not explosion proof. Never use a flammable gas or an explosive gas as a fluid and never use this product in the presence of such gases. Please contact us when fluids other than compressed air are used.

- 4. This product is not explosion-protected.**

Never use this product in locations where the explosion of dust is likely to occur or flammable or explosive gases are used. This can cause fire.

### Caution

- 1. This product is not washed. When bringing into a clean room, flush for several minutes and confirm the required cleanliness before using.**

## Mounting

### Warning

- 1. Reserve enough space for maintenance, piping and wiring**

Please take into consideration that the one-touch fittings need enough space for air tubing to be easily attached/detached. To avoid excessive stress on the connector and one-touch fitting, please take into consideration the air tubing minimum bending radius and avoid bending at acute angles. Wiring with excessive twisting, bending, etc. can cause malfunction, wire breakage, fire or air leakage.

Minimum bending radius:  
Power cable, connection cable A .....35 mm  
Sensor cable, connection cable B.....25 mm

(Note: Wiring with the fixed minimum allowable bending radius and at a temperature of 20 °C shown above. If used under this temperature, the connector can receive excessive stress even though the minimum bending radius is allowable.)

Regarding the minimum bending radius of the air tubing, refer to the instruction manual or catalogue for tubing.

- 2. Mount this product on a plane surface.**

If there are irregularities, cracks or height differences, excessive stress will be applied to the frame or case, resulting in damage or other trouble. Also, do not drop or apply a strong shock. Otherwise, damage or an accident may occur.

## Mounting

### Warning

- 3. Do not use this product in areas where noise (electric magnetic field or surge voltage, etc.) is generated.**

Using the ionizer under such conditions may cause malfunction or internal devices to deteriorate or break down. Take noise countermeasures against noise and prevent the lines from mixing or coming into contact with each other.

- 4. Consider the tightening torque requirements when mounting the ionizer. Refer to the table below for tightening torques for screws, etc.**

If overtightened with a high torque, the mounting screws or mounting brackets may break. Also, if undertightened with a low torque, the connection may loosen.

Thread size	Recommended tightening torque
M3	0.61 to 0.63 N·m
M4	0.73 to 0.75 N·m
M5	1.3 to 1.5 N·m

- 5. Do not touch the electrode needle directly with fingers or metallic tools.**

If a finger is used to touch the electrode, it may get stuck or an injury or electrical shock may occur from touching the surrounding equipment.

In addition, if the electrode needle or cartridge is damaged with a tool, the specification will not be met and damage and/or an accident may occur.

### Danger High Voltage!

Electrode needles are under high voltage. Never touch them as there is a danger of electric shock or injury due to an evasive action against a momentary electrical shock caused by inserting foreign matter in the electrode cartridge or touching the electrode needle.

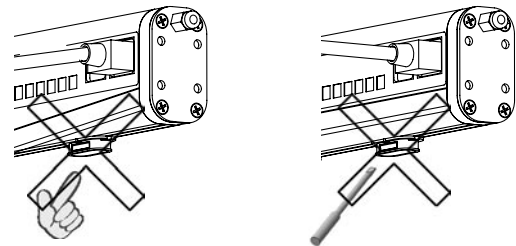

- 6. Do not affix any tape or seals to the body.**

If the tape or seal contains any conductive adhesive or reflective paint, a dielectric phenomenon may occur due to ions arising from such substances, resulting in electrostatic charging or electric leakage.

- 7. Installation and adjustment should be conducted after turning the power supply off.**



# Series IZS31 Ionizers Precautions 2

Be sure to read this before handling.

## Mounting

### ⚠ Caution

1. Install the ionizer away from walls as illustrated below.

If a wall is located closer than that in the illustration below, the ions generated will not be able to reach the object which requires static electricity elimination and therefore result in a decrease in efficiency.

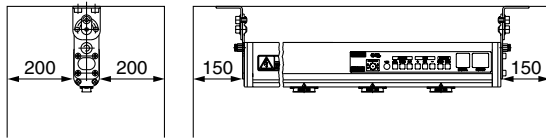

Unit: mm

**After installation, be sure to verify the effects of static electricity elimination.**

The effects vary depending on the ambient conditions, operating conditions, etc. After installation, verify the effects of static electricity elimination.

2. Install a feedback sensor away from walls as illustrated below.

The ionizer may fail to measure electrostatic potentials correctly if a wall or other obstacle exists within the clearances shown in the following figure.

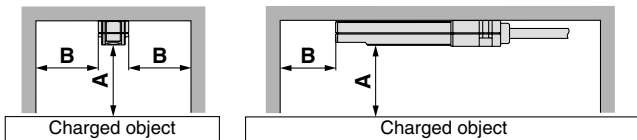

(mm)

A	B
10	20
20	40
25	45
30	55
40	65
50	75

## Wiring / Piping

### ⚠ Warning

1. Confirm if the power supply voltage is enough and that it is within the specifications before wiring.

Always use a UL Listed/Recognised power supply (24 VDC, Class-2 output of 2.1 A or less).

## Wiring / Piping

### ⚠ Warning

2. Be sure to provide Class-D grounding in order to maintain product performance.

If such grounding is not provided, not only may the ion balance be disrupted but electric shocks may also result and the ionizer or power supply may break down.

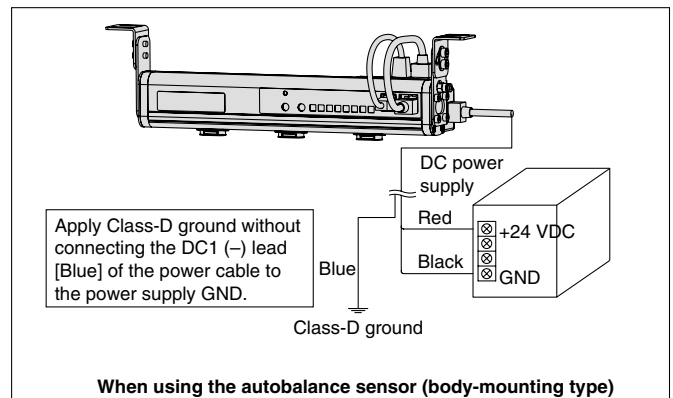
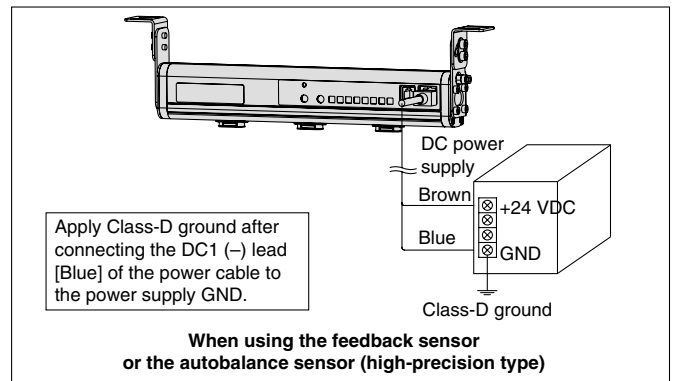

3. Be sure to turn the power supply off before wiring (including attachment/detachment of the connector).
4. To connect a feedback sensor or autobalance sensor to the ionizer, use the cable included with the sensor. Do not disassemble or modify the ionizer.
5. When applying the power supply, pay special attention to the wiring and/or surrounding environment until safety is confirmed.
6. Do not connect or remove any connectors including the power supply, while power is being supplied. Otherwise, the ionizer may malfunction.
7. If the power line and high-pressure line are routed together, this product may malfunction due to noise. Therefore, use a separate wiring route for this product.
8. Be sure to confirm there are no wiring errors before turning this product on. Incorrect wiring will lead to damage or malfunction of the product.
9. Flush pipings before using. Before piping this product, prevent particles, water drops, or oil contents from entering the piping.



# Series IZS31 Ionizers Precautions 3

Be sure to read this before handling.

## Operating Environment / Storage Environment

### Warning

#### 1. Consider the fluid temperature and ambient temperature range.

Fluid and ambient temperature ranges are 0 to 50°C for the ionizer, feedback sensor and autobalance sensor. Do not use the ionizer in locations subjected to sudden temperature changes even if the ambient temperature range is within the specified limits, as condensation may result.

#### 2. Do not use this product in an enclosed space.

This product is based on the corona discharge phenomenon. Do not use the product in an enclosed space as ozone and nitrogen oxides exist in such places, even though in marginal quantities.

#### 3. Environments to avoid

Avoid using and storing this product in the following environments since they may cause damage to this product.

- a) Avoid using in places exceeding an ambient temperature range of 0 to 50°C.
- b) Avoid using in places exceeding an ambient humidity range of 35 to 80% Rh.
- c) Avoid using places where condensation occurs due to a dramatic temperature change.
- d) Avoid using in the presence of corrosive or explosive gas or where there is a volatile combustible.
- e) Avoid using in atmospheres where there are particles, conductive iron powders, oil mist, salt, solvent, blown dust, cutting oil (water, liquid), etc.
- f) Avoid using in places where ventilated air from an air conditioner is directly applied to the product.
- g) Avoid using in closed places without ventilation.
- h) Avoid using in direct sunlight or radiated heat.
- i) Avoid using in places under strong magnetic noise (strong electric field, strong magnetic field, or surge).
- j) Avoid using in places where static electricity is discharged to the body.
- k) Avoid using in places where a strong high frequency occurs.
- l) Avoid using in places where this product is likely to be damaged by lightning.
- m) Avoid using in places where direct vibration or shock is applied to the body.
- n) Avoid using in places where there is a force large enough to deform the body or weight is applied to the product.

#### 4. Do not use air containing mist or dust.

Air containing mist or dust will cause the performance to decrease and shorten the maintenance cycle. Supply clean compressed air by using an air dryer (IDF series), an air filter (AF/AFF series), and a mist separator (AFM/AM series)

#### 5. The ionizer and sensors are not protected against surge caused by lightning.

## Maintenance

### Warning

#### 1. Periodically (every two weeks or so) inspect the ionizer and clean the electrode needles.

Conduct regular maintenance to check if the product is running having a disorder.

Maintenance should be conducted by a fully knowledgeable and experienced person.

If particles attach to the electrode needle after long periods of time, usage the static electricity eliminating performance will be lowered.

Replace the electrode cartridge if the pins are rough and the static electricity eliminating performance does not return even after cleaning.

### Danger High Voltage!

This product contains a high voltage generation circuit. When performing maintenance inspection, be sure to confirm that the power supply to the ionizer is turned off. Never disassemble or modify the ionizer, as this may not only impair the product's functionality but could cause an electric shock or electric leakage.

#### 2. When cleaning the electrode needle or replacing the electrode cartridge, be sure to turn the power supply to the body off.

Touching an electrode needle when it is electrified may result in electric shock or other accidents.

#### 3. Do not disassemble or modify this product.

Otherwise, an electrical shock, damage and/or a fire may occur. Also, disassembled or modified products may not achieve the performance guaranteed in the specifications; the product will not be guaranteed.

## Handling

### Warning

#### 1. Do not drop, bump or apply excessive impact (10 G or more) while handling.

Even though it does not appear to be damaged, the internal parts may be damaged and cause malfunction.

#### 2. When mounting/dismounting the cable, use your finger to pinch the claw of the modular plug, then attach/detach it correctly. If the modular plug is at a difficult angle to attach/detach, the modular jack's mounting section may be damaged and cause disorder.

#### 3. Do not operate this product with wet hands.

Otherwise, an electrical shock or accident may occur.

# Related Products

## Ionizer Nozzle type *Series IZN10*

Dust removal and static electricity elimination by air blow

- Eliminates dust clinging to lamp covers.

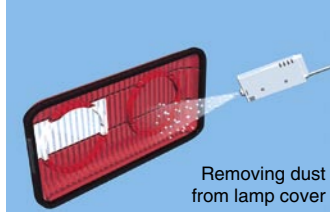

Spot type static electricity elimination

- Prevents electrostatic breakdown of electric parts.
- Prevents detachment failure.

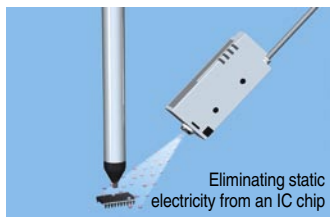

**Ion balance  $\pm 10$  v** (In case of energy-saving static electricity elimination nozzle)

**Slim design: Thickness 16 mm**

**RoHS compliant**

### ① Electrode needle contamination detector

Outputs the maintenance signal when detects contamination or wear of an electrode needle.

**Detects optimal maintenance time, reduced labor for maintenance.**

### ② Built-in power supply substrate

High-voltage power supply cable/ external high-voltage power supply are unnecessary.



CAT.EUS100-72



## Electrostatic Sensor *Series IZD10* / Electrostatic Sensor Monitor *Series IZE11*

### Electrostatic Sensor *Series IZD10*

The importance of the static electric control is put on confirming the “current status”.

- Potential measurement:  $\pm 20$  kV (detected at a 50 mm distance)  
 $\pm 0.4$  kV (detected at a 25 mm distance)
- Detects the electrostatic potential and outputs in an analogue voltage
  - Output voltage: 1 to 5 V (Output impedance: Approx. 100  $\Omega$ )
- Possible to measure electrostatic potential



### Electrostatic Sensor Monitor *Series IZE11*

- Output: Switch output x 2 + Analogue output (1 to 5 V, 4 to 20 mA)
- Minimum unit setting: 0.001 kV (at  $\pm 0.4$  kV), 0.1 kV (at  $\pm 20$  kV)
- Display accuracy:  $\pm 0.5\%$  F.S.  $\pm 1$  digit or less
- Detection distance correction function (adjustable in 1 mm increments)
- Range switching supports two sensors. ( $\pm 0.4$  kV,  $\pm 20$  kV)



CAT.EUS100-65



## Handheld Electrostatic Meter *Series IZH10*

The importance of the static electric control is put on confirming the “current status”.

Easy-to-use handheld electrostatic meter

- Measuring range:  $\pm 20.0$  kV
- Minimum unit display: 0.1 kV ( $\pm 1.0$  to  $\pm 20.0$  kV)  
0.01 kV (0 to  $\pm 0.99$  kV)
- Compact & Lightweight: 85 g (excluding dry cell batteries)
- Backlight for reading in the dark
- LOW battery indicator
- Peak/Bottom display function
- Zero-out function
- Auto power-off function



CAT.EUS100-69



## SMC can provide all the equipment required to supply air to the ionizer.

Consider the equipment below not only for providing an “opportunity to decrease maintenance” and “preventing damage” but also for an “energy-saving countermeasure”.

### Recommended pneumatic circuit diagram

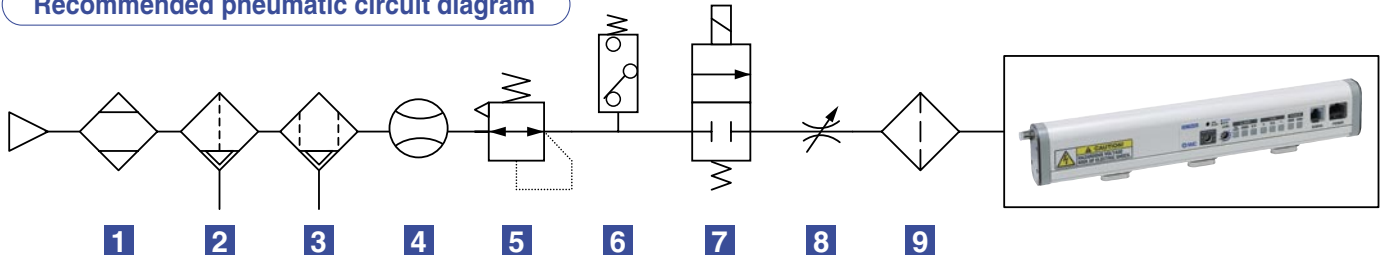

#### 1 Air Dryer / Series IDF

Decreases the dew point of compressed air. Limits moisture generation which can lead to damage.



#### 2 Air Filter / Series AF

Eliminates solid foreign matter such as powder particles in the compressed air.



#### 3 Mist Separator / Series AFM

Eliminates oil mist which is difficult to eliminate with an air filter.



#### 4 Digital Flow Switch / Series PF2A

Decreases air consumption with flow control.



#### 2-Colour Display Digital Flow Switch / Series PFM



#### 5 Regulator / Series AR

Decreases air consumption by setting to an appropriate pressure.



#### 6 Digital Pressure Switch / Series ISE30

Pressure control prevents the static electricity removal performance from being reduced in accordance with the reduction of air the pressure.

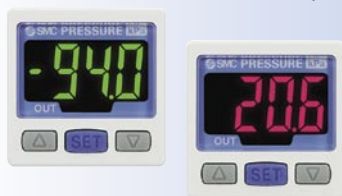

#### 7 2 Port Solenoid Valve /



#### 8 Restrictor / Series AS-X214

Regulates to the appropriate air volume depending on the installation conditions. Decreases air consumption.



#### 9 Clean Air Filter / Series SFD

Built-in capillary element  
Nominal filtration rating: 0.01  $\mu\text{m}$   
Hollow fiber elements with over 99.99% filtering efficiency do not contaminate workpieces.

