

Steckverbinder nach DIN 41612 / IEC 60603-2

Bauform D

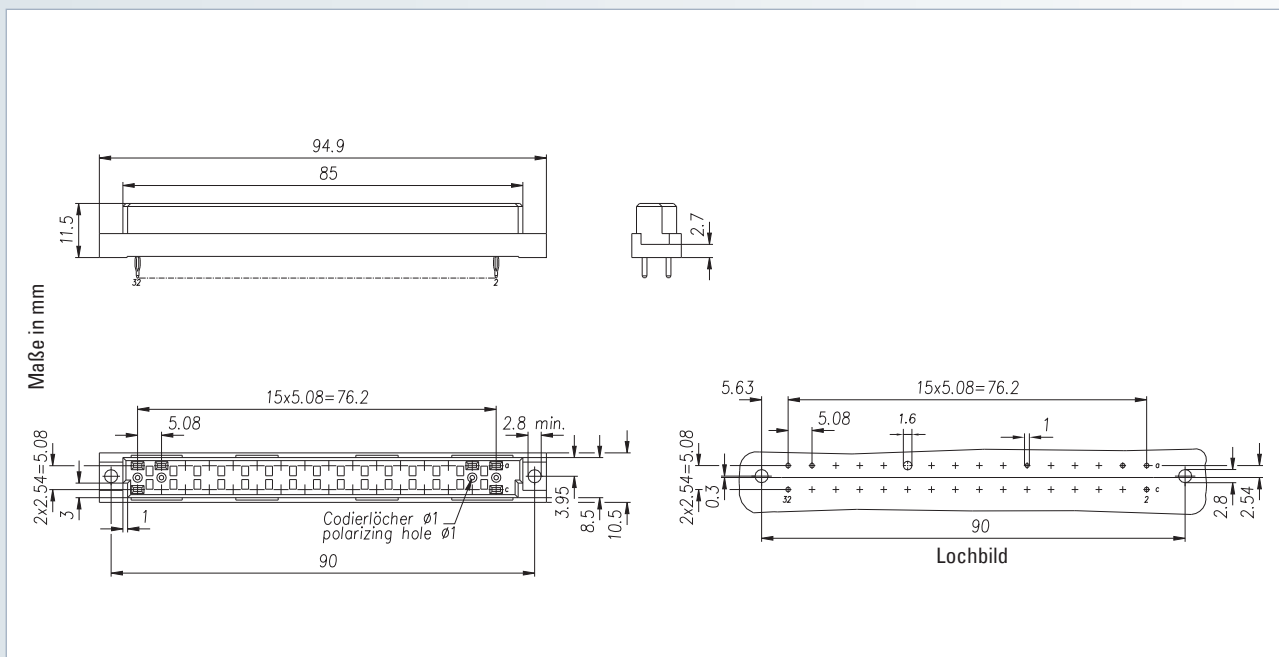

Federleiste

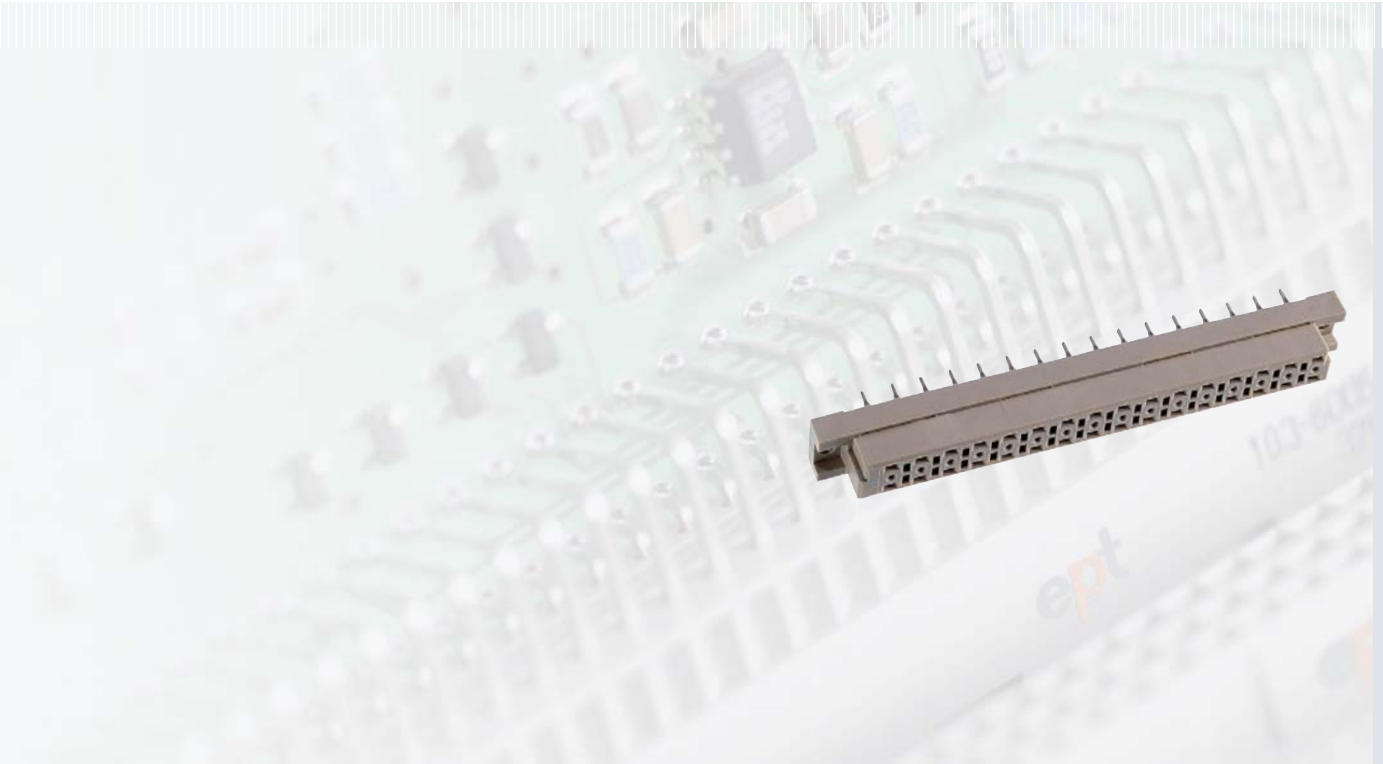

Polzahl	Belegungsbild	Einpresstechnik – Gütestufe II		
		Anschlusslänge		
Artikelnummer				
32		106-60084	106-60064	106-60065

Zubehör – Einpresswerkzeug (siehe S. 208) – Gegenhalter (siehe S. 209) – Kodierungszubehör (siehe S. 160)	Auf Anfrage – Gütestufen I + III oder kundenspezifisch – Sonderlänge für Anschlüsse	Optionen – ohne Befestigungsflansch – Sonderbestückung (siehe S. 162)
---	--	--

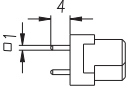
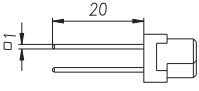
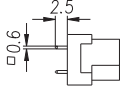
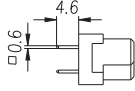

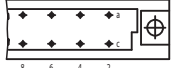
Polzahl	Belegungsbild	Löttechnik – Gütestufe II				
		Anschlusslänge				
						
Artikelnummer						
32		106-40064	106-40065	106-40084	106-40075	106-40066

Zubehör – Kodierungszubehör (siehe S. 160)	Auf Anfrage – Gütestufen I + III oder kundenspezifisch – Sonderlänge für Anschlüsse – auch in THTR Technik	Optionen – Board-Lock (siehe S. 159) – Sonderbestückung (siehe S. 162)
--	--	---