

GN 614.6 Bolt spring plungers

Smooth body, steel



- 1
- 2
- 3
- 4
- 5
- 6
- 7
- 8
- 9
- 10
- 11
- 12
- 13
- 14
- 15
- 16
- 17
- 18

BODY

Black-oxide steel.

PLUNGER

Case-hardened and black-oxide steel.

SPRING

AISI 631 stainless steel.

FEATURES AND APPLICATIONS

GN 614.6 bolt spring plungers are mainly used in the production of tools such as spring stops as well as for their pressure and blocking functions.

Suggested tolerance for plunger housing hole = H7.

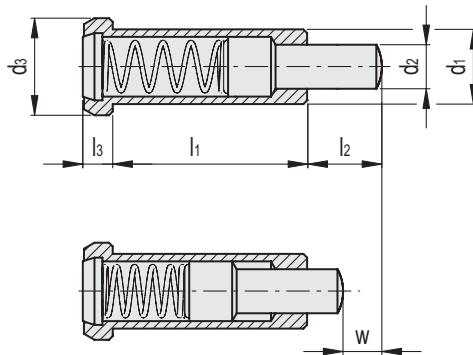

Code	Description	d1-0.05	d2	d3	l1	l2	l3	w	Spring preload [N]	Spring max load [N]	
GN.32701	GN 614.6-6-K	6	2.7	8	20	6	3.2	3.5	10	22	4
GN.32703	GN 614.6-8-K	8	3.9	10	24	8	3.2	4.5	30	88	8
GN.32705	GN 614.6-10-K	10	5.9	13	30	10	4	5.5	42	1110	16
GN.32707	GN 614.6-12-K	12	7.9	16	36	12	5	6.5	50	130	27

Indexing and positioning elements