

OT 400/220...240/ 1A4 2DIM P7 AUX12

OPTOTRONIC - 2DIM High Power IP67 AUX12 | 2DIM, AUX power, IP67 – constant current LED drivers



Product family features

- Available with different wattage: 400 W, 600 W
- Supply voltage: 220...240 V
- AUX 12V output for sensor and wireless node
- Wide output current range
- Lifetime: up to 100,000 h (at $T = 75\text{ °C}$ at T_c)

Product family benefits

- Easily programmable by OT Programmer-S; (AstroDIM / Constant lumen)
- Efficient and reliable
- 2DIM functionality in one device (AstroDIM, 1...10 V)
- High surge protection: up to 10 kV
- Great flexibility due to wide operating temperature range of -40...55 °C
- Lifetime: up to 100,000 h
- IP rating: IP67
- 5 years guarantee

Areas of application

- Area lighting
- Stadium lighting
- Horticulture lighting
- Street and urban lighting
- Suitable for luminaires of protection class I

Technical data

Electrical data

Nominal voltage	220...240 V
Input voltage AC	198...264 V
Nominal current	2.2 A ¹⁾
Mains frequency	50...60 Hz
Power factor λ	0.95 ²⁾
Total harmonic distortion	< 10 % ³⁾
Device power loss	23 W ¹⁾
Inrush current	60 A ⁴⁾
Max. ECG no. on circuit breaker 10 A (B)	1
Max. ECG no. on circuit breaker 16 A (B)	3
Max. ECG no. on circuit breaker 25 A (B)	5
Surge capability (L/N-Ground)	10 kV ⁵⁾
Surge capability (L-N)	6 kV
Nominal output power	400 W
Maximum output power	400 W ⁶⁾
Efficiency in full-load	92 % ⁷⁾
Nominal output current	1050...1400 mA
Default output current	1400 mA
Output current tolerance	±5 %
Output ripple current (100 Hz)	6 %
Output PSTLM	≤1
Output SVM	≤0.4
Minimum output current	1050 mA
Galvanic isolation	basic
Nominal output voltage	247...380 V

¹⁾ V_{in} 230V 50Hz

²⁾ Full load at 230 V/50 Hz

³⁾ At full load

⁴⁾ Max, $t_h = 630\mu s$ @ 50% I_{pk}

⁵⁾ L - N acc to EN 61547 (>15 pulses) / L/N - PE acc to EN 61547 (>15 pulses)

⁶⁾ LED output

⁷⁾ at 230 V, 50 Hz

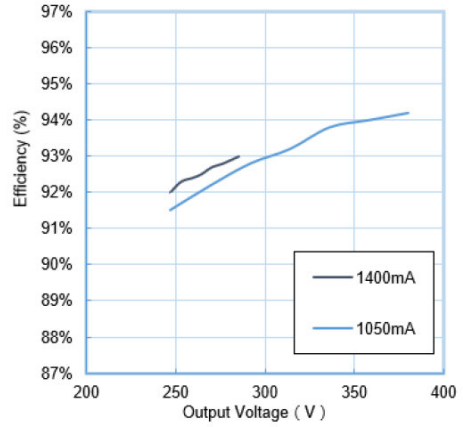
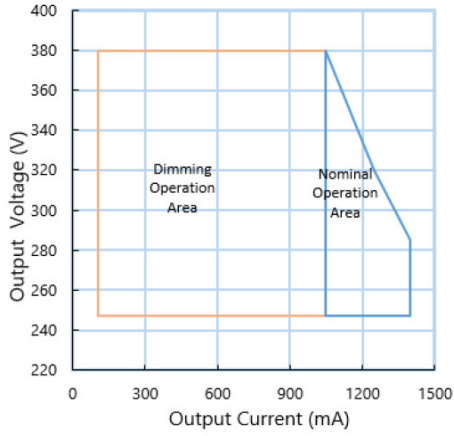

OT 400 1A4 2DIM P7 AUX12 Operating Window

OT 400 1A4 2DIM P7 AUX12 Typical Efficiency vs. Load (230V 50 Hz)

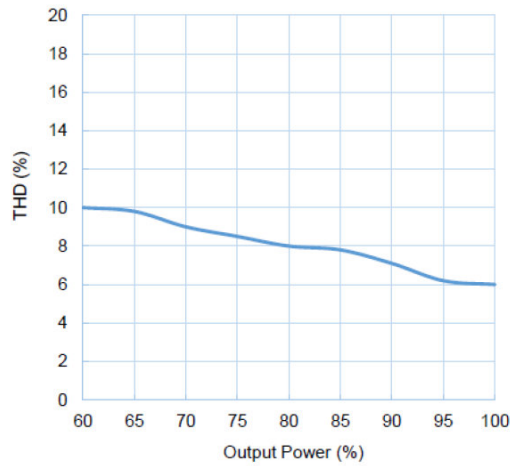
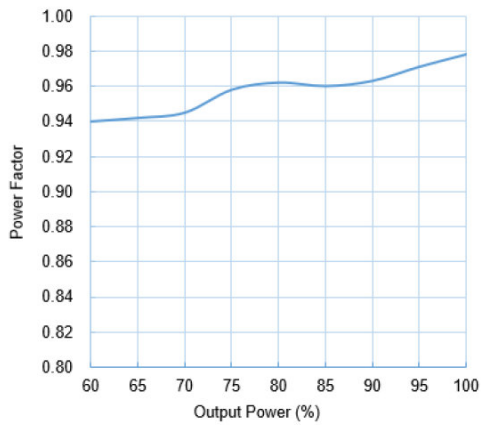

OT 400 1A4 2DIM P7 AUX12 Typical Power Factor vs. Load

OT 400 1A4 2DIM P7 AUX12 Typical THD vs Load

Product datasheet

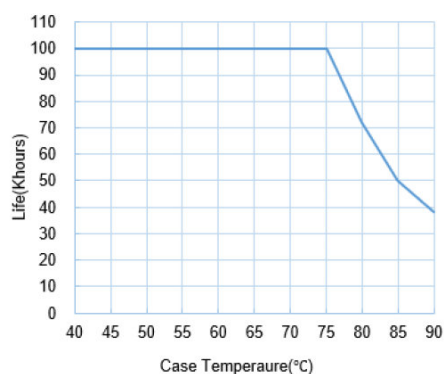

OT 400 1A4 2DIM P7 AUX12 Lifetime vs. Case Temp

Dimensions & weight

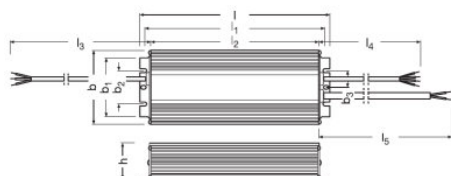

Length	252.0 mm
Width	89.5 mm
Height	44.5 mm
Mounting hole spacing, length	238.5 mm
Mounting hole spacing, width	40 mm
Product weight	1980.00 g
Cable cross-section, input side	1.0 mm ² ¹⁾
Cable cross-section, output side	1.0 mm ² ²⁾
Wire preparation length, input side	10 mm

¹⁾ L (Brown/BN), N (Blue/BU), PE(Green/Yellow, GNYE)

Product datasheet

Commodity code	850440839000
----------------	--------------

Environmental information

Information according Art. 33 of EU Regulation (EC) 1907/2006 (REACH)	
Date of Declaration	29-06-2022
Primary Article Identifier	4052899624221
Candidate List Substance 1	Lead
CAS No. of substance 1	7439-92-1
Safe Use Instruction	The identification of the Candidate List substance is sufficient to allow safe use of the article.
Declaration No. in SCIP database	55191251-7c21-4420-a0da-0d3cf4441a48

Wiring Diagram

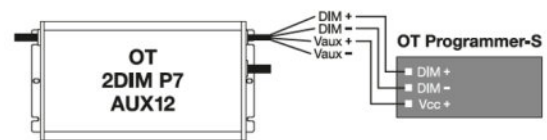
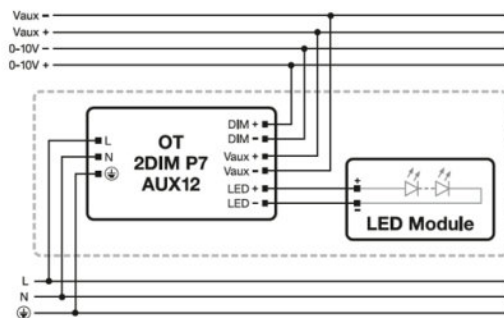

Wiring Diagram of OT 2DIM P7 AUX12





Programming Diagram of OT 2DIM P7 AUX12

Product datasheet

Additional product information

- Input voltage range: Nominal operation at 198 – 264 Vac.
- Output short circuit protection: shut down of driver occur in case of output short circuit without damage to the unit.
- Output over load/voltage protection: In case the input voltage of the load exceeds the output voltage range which is auto defined by output current setting of the driver ($V_o = P_o / I_o$), it automatically reduces the output current. Auto-reversible without mains power on/off;
- No load protection: the driver automatically adjusts the output voltage to the maximum output voltage which is auto defined by output current setting if no load is connected. Auto-reversible with the correct load connected;
- Over temperature protection: the driver is protected against temporary overheating by shutting down until the overheating eliminated; Auto-reversible when temperature back to normal;
- Disconnect the power before servicing. Terminal block is not included, installation must be performed by qualified person;
- The protective earth (GNYE/PE wire, housing) has to be connected to the heat sink of the LED module to improve the capability of the system to withstand a surge and EMI in critical luminaires.
- Not suitable to be mounted in ceiling corner
- The LED control gear cannot be abutted against or covered by normally flammable materials or used in installations where building insulation or debris is, or may be, present in normal use.
- The external flexible cable or cord of this driver cannot be replaced; if the cord is damaged, the driver shall be destroyed.
- The dimmer should fulfill at least basic insulation between control voltage and dimming circuit (for Australia and New Zealand).
- The startup time to reach the set output current is less than 2s.
- For further details please consult the application note;
- AUX 12V output for sensor and wireless node (max. 200 mA)
- For output cable > 2m EMC conformity is not guaranteed and must be ensured by OEM

Download Data

File	
	User instruction OPTOTRONIC 2DIM P7 AUX12
	Certificates CCC certificate OT 400W 2DIM P7 AUX12
	Certificates ENEC OT 400W 2DIM P7 AUX12
	Certificates CB certificate OT 400W 2DIM P7 AUX12
	Certificates RCM Certificate OT 400 2DIM P7 AUX12

Product datasheet

Ecodesign regulation information:

Intended for use with LED modules.

The forward voltage of the LED light source shall be within the defined operating window of the control gear in all operating conditions including dimming if applicable.

Separate control gear and light sources must be disposed of at certified disposal companies in accordance with Directive 2012/19/EU (WEEE) in the EU and with Waste Electrical and Electronic Equipment (WEEE) Regulations 2013 in the UK. For this purpose, collection points for recycling centres and take-back systems (CRSO) are available from retailers or private disposal companies, which accept separate control gear and light sources free of charge. In this way, raw materials are conserved and materials are recycled.

Logistical Data

Product code	Product description	Packaging unit (Pieces/Unit)	Dimensions (length x width x height)	Volume	Gross weight
4052899624221	OT 400/220...240/ 1A4 2DIM P7 AUX12	Shipping carton box 6	506 mm x 398 mm x 136 mm	27.39 dm ³	13000.00 g

The mentioned product code describes the smallest quantity unit which can be ordered. One shipping unit can contain one or more single products. When placing an order, for the quantity please enter single or multiples of a shipping unit.

References / Links

* For more information on the multi-level guarantee and the terms and conditions of the guarantee visit

▶ www.osram.com/system-guarantee

Disclaimer

Subject to change without notice. Errors and omission excepted. Always make sure to use the most recent release.
