

Przeguby kątowe DIN 71802 forma CS

Opis artykułu/ilustracje produktu



Opis

Materiał:

Stal lub stal nierdzewna 1.4305.

Wersja:

cyklowane i pasywowane. Wersja ze stali nierdzewnej niepowlekanej.

Wskazówka:

Z pierścieniem rozprężnym.

Rysunki

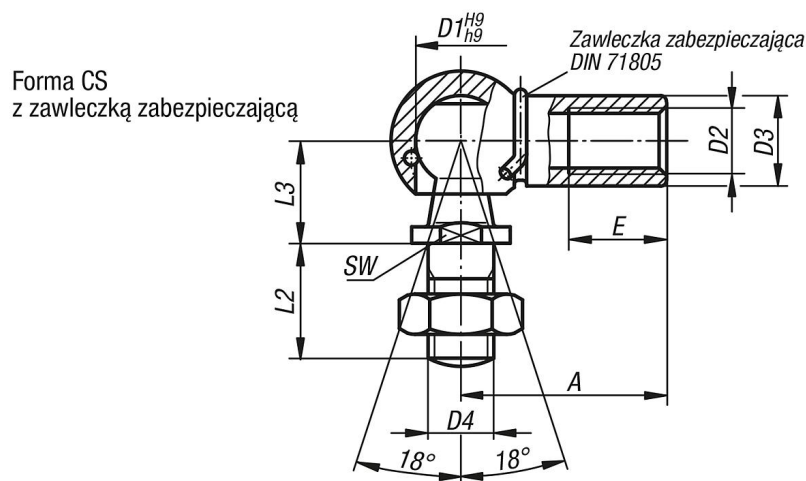

Przegląd artykułów

Nr Zamówienia	Forma	Wersja 2	Materiał korpusu	D1	D2	D3	D4	A	L2	L3	E	SW
K0734.080351	CS	gwint prawy	stal	8	M3,5	8	M4	18	10,2	9	8	7
K0734.08051	CS	gwint prawy	stal	8	M5	8	M5	22	10,2	9	10,2	7
K0734.10061	CS	gwint prawy	stal	10	M6	10	M6	25	12,5	11	11,5	8
K0734.13081	CS	gwint prawy	stal	13	M8	13	M8	30	16,5	13	14	11
K0734.16101	CS	gwint prawy	stal	16	M10	16	M10	35	20	16	15,5	13
K0734.16121	CS	gwint prawy	stal	16	M12	16	M12	35	20	16	15,5	13
K0734.19141	CS	gwint prawy	stal	19	M14x1,5	22	M14x1,5	45	28	20	21,5	16
K0734.19161	CS	gwint prawy	stal	19	M16	22	M16	45	28	20	21,5	16
K0734.080511	CS	gwint lewy	stal	8	M5	8	M5	22	10,2	9	10,2	7
K0734.100611	CS	gwint lewy	stal	10	M6	10	M6	25	12,5	11	11,5	8
K0734.130811	CS	gwint lewy	stal	13	M8	13	M8	30	16,5	13	14	11
K0734.161011	CS	gwint lewy	stal	16	M10	16	M10	35	20	16	15,5	13
K0734.161211	CS	gwint lewy	stal	16	M12	16	M12	35	20	16	15,5	13
K0734.191411	CS	gwint lewy	stal	19	M14x1,5	22	M14x1,5	45	28	20	21,5	16
K0734.191611	CS	gwint lewy	stal	19	M16	22	M16	45	28	20	21,5	16
K0734.08052	CS	gwint prawy	stal nierdzewna	8	M5	8	M5	22	10,2	9	10,2	7
K0734.10062	CS	gwint prawy	stal nierdzewna	10	M6	10	M6	25	12,5	11	11,5	8
K0734.13082	CS	gwint prawy	stal nierdzewna	13	M8	13	M8	30	16,5	13	14	11
K0734.16102	CS	gwint prawy	stal nierdzewna	16	M10	16	M10	35	20	16	15,5	13
K0734.16122	CS	gwint prawy	stal nierdzewna	16	M12	16	M12	35	20	16	15,5	13
K0734.080521	CS	gwint lewy	stal nierdzewna	8	M5	8	M5	22	10,2	9	10,2	7
K0734.100621	CS	gwint lewy	stal nierdzewna	10	M6	10	M6	25	12,5	11	11,5	8
K0734.130821	CS	gwint lewy	stal nierdzewna	13	M8	13	M8	30	16,5	13	14	11

Przeguby kątowe DIN 71802 forma CS

Przegląd artykułów

Nr Zamówienia	Forma	Wersja 2	Materiał korpusu	D1	D2	D3	D4	A	L2	L3	E	SW
K0734.161021	CS	gwint lewy	stal nierdzewna	16	M10	16	M10	35	20	16	15,5	13
K0734.161221	CS	gwint lewy	stal nierdzewna	16	M12	16	M12	35	20	16	15,5	13