

Applications

- Automotive
- Instrumentation
- White goods
- Telecommunications

Benefits

- RoHS Compliant
- Halogen and Lead Free
- Sharp detection feeling
- Compact Size

JJ Series – Detector Switches

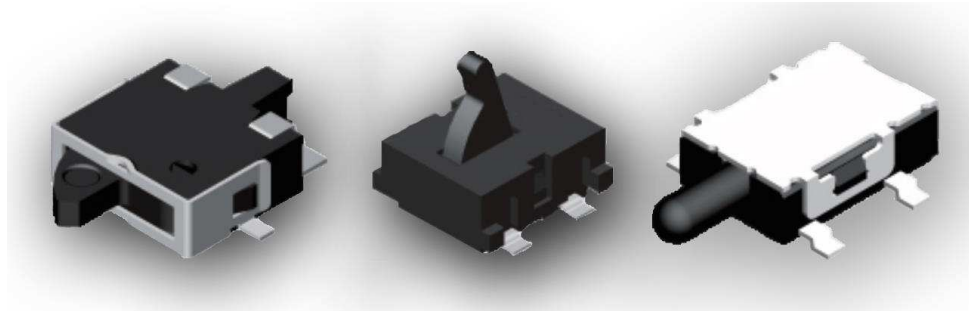

TE Connectivity is pleased to introduce its JJ Series of Detector Switches, suitable for a wide variety of applications given their several presentations ranging from horizontal or vertical actuated options as well as Gull-winged, J-leaded and Through-Hole mounting possibilities.

The Detector Switches will be offered in a wide range of sizes giving the possibility for countless applications going from automotive to telecommunications.

JJ Series – Family Classification

Series	Body Size
JJA	3.5x2.8 mm
JJB	3.5x2.98 mm
JJC	3.5x3.3 mm
JJD	4.2x3.6 mm
JJE	4.7x3.5 mm
JJF	4.7x3.8 mm
JJG	5.7x4.0 mm (High-Rating)
JJH	5.7x4.0 mm (Standard-Rating)
JJI	5.0x4.4 mm
JJJ	6.0x4.85 mm / 5.5x4.7 mm
JJK	6.3x3.0 mm
JJL	6.5x3.9 mm
JJM	5.7x4.0 mm
JJN	5.7x4.0 mm (Wedge)
JJO	10.0x3.8 mm
JJP	10.6x10.0 mm

JJO Family – 10.0x3.8 mm

	Contact Rating	1mA, 5VDC
	Contact Resistance	500mΩ Max.
	Insulation Resistance	100MΩ Min. 500VDC
	Dielectric Strength	300VAC/1 minute
	Operating Force	40gF Max.
	Operating Life	100,000 cycles
	Operating Temperature	-40°C to 85°C

Features	Applications
<ul style="list-style-type: none"> • Easy orientation provided by guiding post • Wedge type actuator 	<ul style="list-style-type: none"> • Automotive. • Telecommunications. • Measurement instrumentations.

Circuit

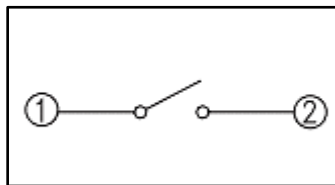

How To Order

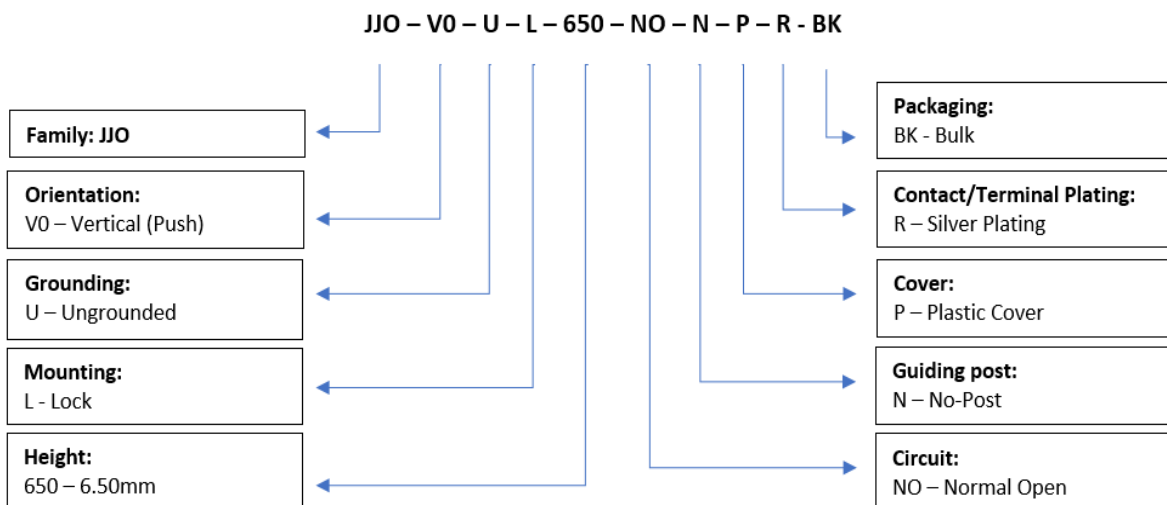

Diagrams

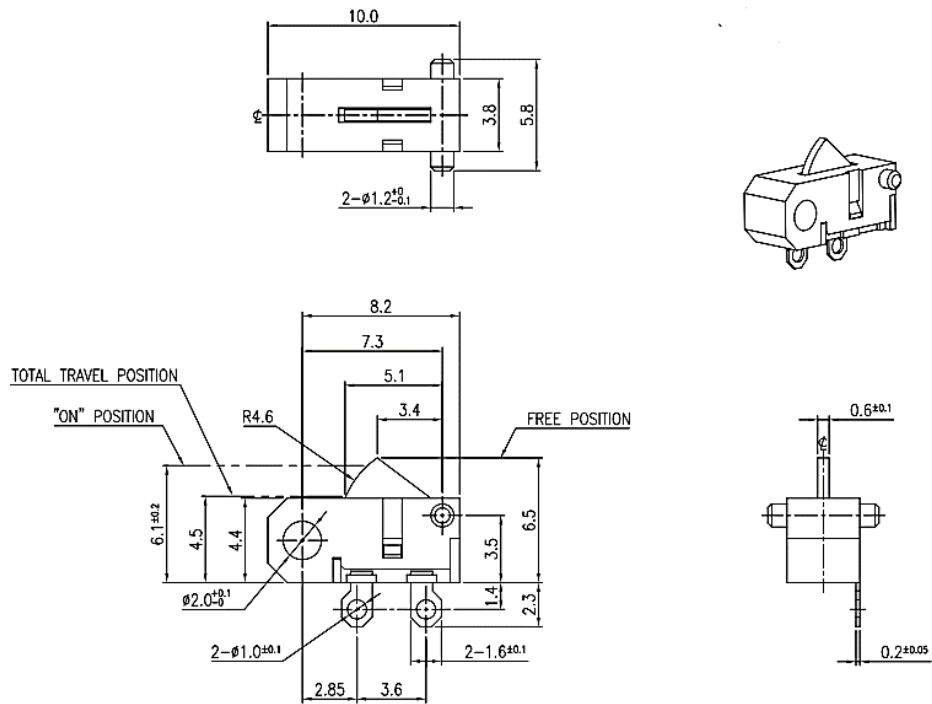

PN List

Smart PN	Orientation	Grounding	Mounting	Height	Circuit	Guiding Post	Cover	Plating	Packaging	MOQ	TE PN
JJOV0UL650NONPRBK	Vertical (Push)	Ungrounded	Lock	6.50mm	NO	No-Post	Plastic	Silver	Bulk	2,000	2331416-1



1. Style

“Detector Switches” are mainly used as signal switches of electric devices, with the general requirements of mechanical and electrical characteristic.

Standard test conditions shall be 5 to 35°C in temperature, 45 to 85%RH in humidity and 86 to 106kPa in atmospheric pressure. Should any doubt arise in judgment, tests shall be conducted at 20±2°C in temperature, 60 to 70%RH in humidity and 86 to 106kPa in atmospheric pressure.

1.1 Operating Temperature Range: -40°C to 85°C

1.2 The shelf life of product is within 6 months.

2. Current Range: 1mA, 5VDC

3. Type of Actuation: Auto Return

4. Test Sequence:

	Item	Description	Test Conditions	Requirements
Appearance	1	Visual Examination	Physical inspection without applying any external forces.	There shall be no defects that affect the serviceability of the product.
Electric Performance	2	Contact Resistance	Shall be measured at 1KHz ± 200Hz (20mV Max, 50mA Max) or 1A 5VDC by voltage drop method.	500mΩ Max.
	3	Insulation Resistance	Measurements shall be made at 500 VDC potential between terminals and cover.	100MΩ Min.
	4	Dielectric Withstanding Voltage	Apply 300 VAC (50Hz or 60Hz) between terminals and cover for 1 minute.	There shall be no breakdown or flashover

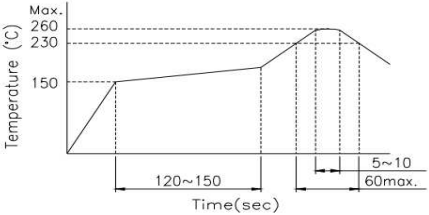
Mechanical Performance	5	Operating Force	Applying force to the center of the stem for 2.7mm	40gF Max.
	6	Terminal Strength	The static load 300gF shall be applied on top of the terminal in every direction for 1 minute.	Shall be free from any terminal damage and looseness and breakage of terminal holding position. Terminal may be bent after test, electrical performance requirement specified in item 4 shall be satisfied.
	7	Solder heat Resistance	<p>Manual Soldering: -Terminal: 350°C Max. -Time: 3 Seconds Max.</p> <p>Reflow Soldering: -2 times or less.</p>  <p>Above mentioned time-temperature chart is based on the temperature on the parts-mounting surface of P.C.B.</p>	<p>1) Shall be free from any pronounced deforming in appearance.</p> <p>2) The electrical performance requirements as per items 2 through 4 shall be satisfied.</p>
Durability	8	Operating Life	<p>Tested as follows: 100,000 cycles operations at a rate of 20 to 30 cycles/min without load. (When pushing the actuator at right angle)</p>	<p>1) Contact resistance: 1Ω Min. 2) Operating force: Between 10 and -30% of initial value.</p> <p>Every part should not defect in appearance and mechanical performance.</p>
Weather-proof	9	Humidity Test	<p>Following the test set forth below the sample shall be left in normal temperature and humidity conditions for 1 hour before the measurements are made: 1) Temperature:40±2°C 2) Relative Humidity: 90 to 95% 3) Time: 168 hours Water drops shall be removed.</p>	<p>1) Insulation resistance: 100MΩ Min. 2) Withstand voltage: To be satisfied with item 4.</p>
	10	Heat Test	<p>Following the test set forth below the sample shall be left in normal temperature and humidity conditions for 1 hour before the measurements are made: 1) Temperature:85±2°C 2) Time: 96 hours Water drops shall be removed.</p>	
	11	Cold Test	<p>Following the test set forth below the sample shall be left in normal temperature and humidity conditions for 1 hour before the measurements are made: 1) Temperature: -20±2°C 2) Time: 96 hours Water drops shall be removed.</p>	

■ Precautions in Handling

1. Care must be taken to ensure excess flux on the top surface of the printed circuit board does not adhere to the switch.
2. Do not wash the switch.

■ Recommended storage conditions:

Store the products in the original packaging material. After opening the package, the remaining products must be stored in the appropriate moisture-proof & airtight environment.

Do not store the switch in the following environment or it may affect performance and solderability:

1. temperatures below -10° C to 40°C & humidity at 85% (min)
2. environment with corrosive gas
3. storage over 6 months
4. place in direct sunlight