

# Dissipateur Thermique avec adaptateur DIN Heatsink with DIN rail adaptor

## WF311100

**Rth : 3K/W**  
 en air calme  
 (@20W) sans ventilation.  
*in air calm (@20W)*  
*without ventilation*

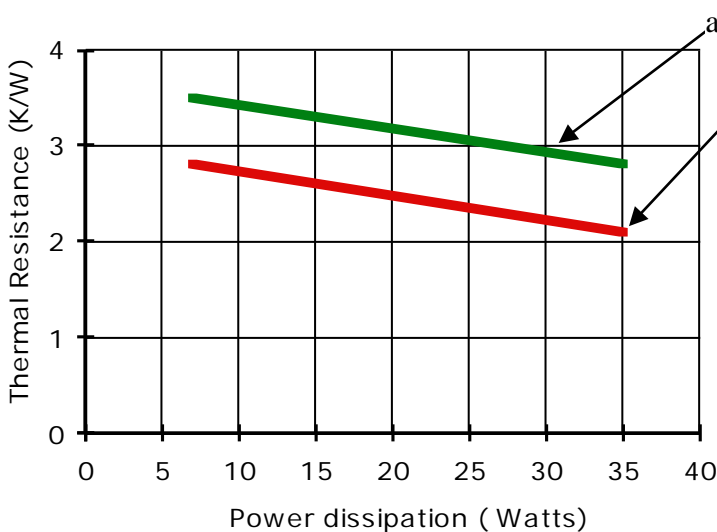
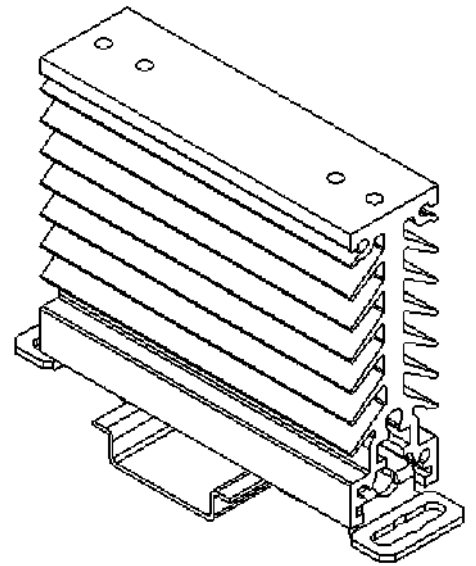
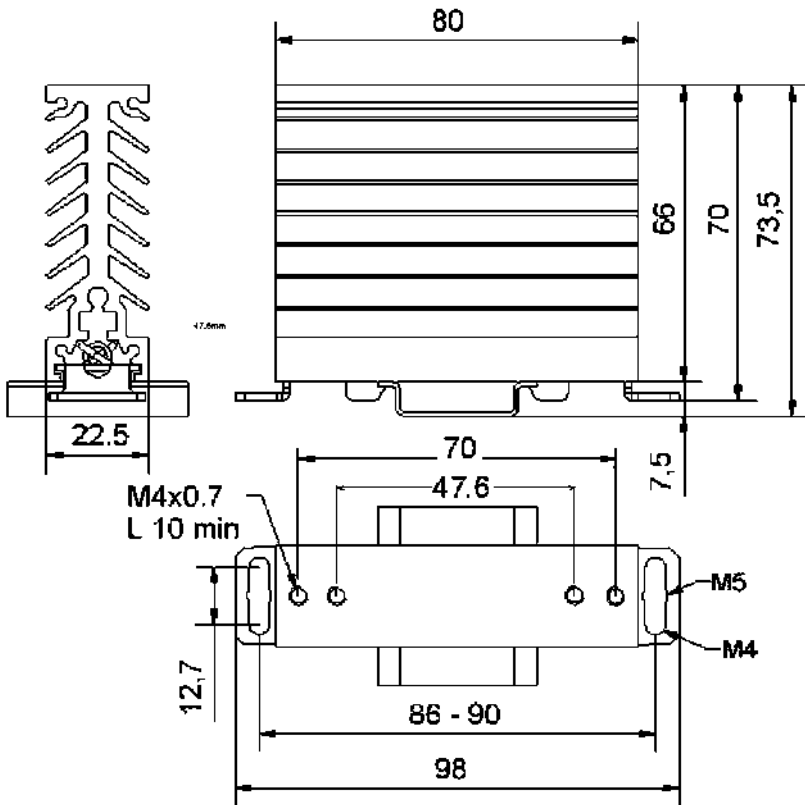

En cas de ventilation, la résistance thermique sera réduite de façon significative.

In case of ventilation, the thermal resistance will be lower.