

PRODUCT NUMBER

SEE SHEET 3

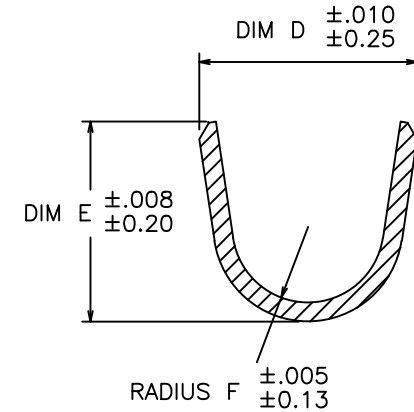
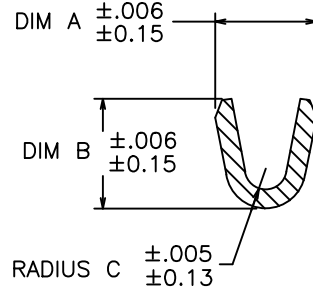
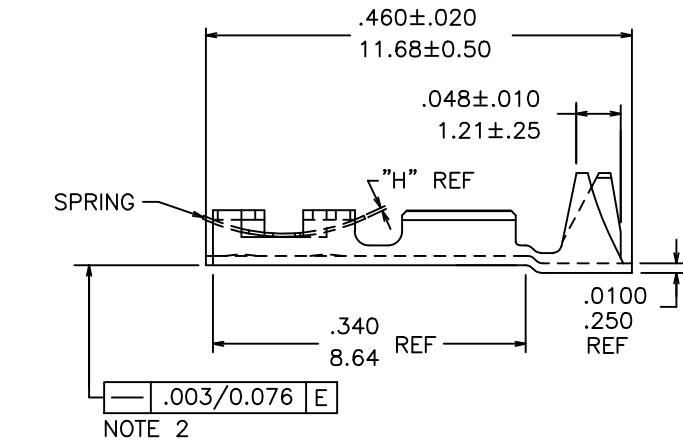
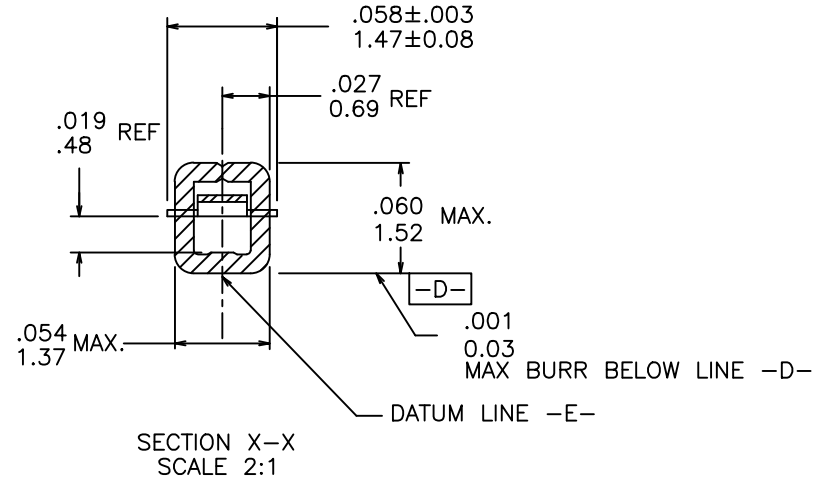
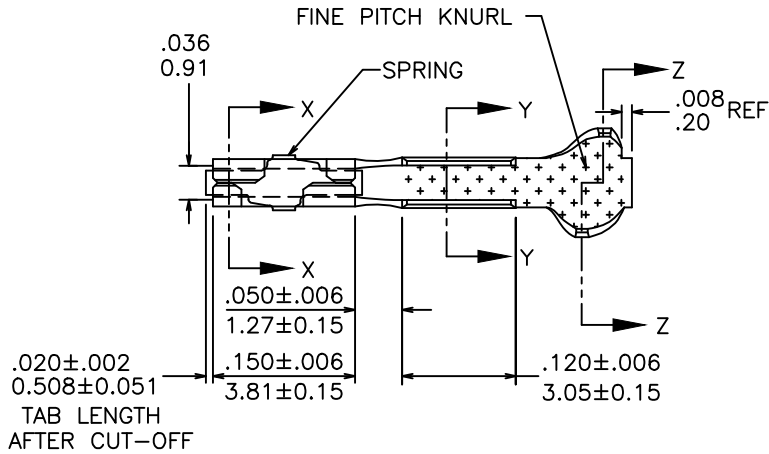

NOTE 2

—	.003/0.076	E
---	------------	---

mat'l. code SEE TABLE				surface <input checked="" type="checkbox"/> tolerance		projection		product family PV TERMINALS			
ltr	ecn no	dr	date	tolerances unless otherwise specified			title				
AN	V12-0006	HTB	12.01.05	angles	linear	.XX±.01/.X±.3	INCH/MM				
AP	F-21694	AMA	15.08.18			.XXX±.005/.XX±.13	scale 5:1				
						.XXX±.0020/.XXX±.13					
				dr	A.MAISIERES	15.07.16			dwg no	sheet 1 of 5	size
				engr	L.MULIN	15.07.16			47212	A3	
				chr							
				app	L.MULIN	15.07.16	type		Product Customer Drawing		
sheet index	revision sheet	AP	AP	AP	AP	AP					

PRODUCT NUMBER SEE SHEET 3	WIRE BARREL		INSULATION BARREL				RECOMMENDED HANDTOOL FOR LOOSE PIECE APPLICATION		
	AWG RANGE	DIM A	DIM B	RADIUS C	INSULATION DIAMETER RANGE	DIM D	DIM E	RADIUS F	
	18-20	.104/2.64	.104/2.64	.021/.53	.042/1.07-.103/2.62	.139/3.53	.120/3.05	.050/1.27	HT-0073
	22-26	.070/1.78	.070/1.78	.017/.43	.036/.91-.103/2.62	.139/3.53	.120/3.05	.050/1.27	HT-0095
	28-32	.054/1.37	.058/1.47	.011/.28	.028/.71-.054/1.37	.115/2.92	.105/2.67	.040/1.02	

NOTES:

1. TERMINAL MATES WITH .025±.002/0.64±0.05 SQUARE OR ROUND PIN.
- ② WHEN MEASURED ALONG DATUM -E- WITHIN .340/8.64 REF DIM.
3. PRODUCT SPECIFICATION: BUS-12-067.
APPLICATION SPECIFICATIONS:
TA-75: TERMINAL DATA FOR USE WITH MINI LATCH HOUSING.
TA-146: TERMINAL DATA FOR CONTACTS NOT USED IN HOUSINGS.
TA-210: TERMINAL DATA FOR CONTACTS USED WITH MINI ROD HOUSINGS.
TA-228: APPLICATIONS USING 20 AWG WIRE.
TA-531: INSTALLING AND REMOVING TERMINALS.
- ④ PRODUCT MEETS EUROPEAN UNION DIRECTIVES AND OTHER COUNTRY REGULATIONS AS DESCRIBED IN GS-22-008.
5. THIS PRODUCT IS NOT INTENDED TO BE EXPOSED TO MANUFACTURING SOLDERING PROCESSES.
- ⑥ THIS PRODUCT HAS 100% TIN PLATING IN THE INTERFACE AND HAS NOT BEEN TESTED FOR WHISKER GROWTH IN ALL INTERCONNECT ENVIRONMENTS.
- ⑦ CONTACT SIDE OF TERMINAL WILL HAVE 50μ"/1.27μm NICKEL UNDERPLATE OVERALL WITH GOLD FLASH REQUIRED INSIDE CONTACT BOX AND WIRE BARREL ONLY. BACKSIDE OF TERMINALS TO BE PLATED WITH 30μ"/0.76μm NICKEL ONLY.

mat'l. code		surface		tolerance		projection		product family		
SEE TABLE		✓				⊕		PV TERMINALS		
ltr	ecn no	dr	date	tolerances unless otherwise specified		INCH/MM		title		
AN	V12-0006	HTB	12.01.05	.XX±.01/.X±.3				MINI PV™ RECEPTACLE		
AP	F-21694	AMA	15.08.18	angles	linear	.XXX±.005/.XXX±.13		CRIMP TO WIRE		
						.XXX±.0020/.XXX±		scale 1:1		
		dr	A.MAISIERES	15.07.16		FCI		dwg no		
		engr	L.MULIN	15.07.16				sheet 2 of 5		size
		chr						47212		A3
		appd	L.MULIN	15.07.16				type		Product Customer Drawing
sheet index	revision sheet									



Copyright FCI

MATERIAL & PLATING		SPRING THICKNESS DIM H±.0005/0.012	AWG RANGE	REELED NOTE 4	LOOSE NOTE 4	PLATING AVAILABILITY					
1/4 HARD BRASS BODY	Be/Cu SPRING					-000	-000LF	-001	-001LF	-002	-002LF
CONTACT AREA UNDERPLATING: 50μ"/1.27μ Ni CONTACT AREA: 15μ"/0.38μ Au INSIDE BOX AREA: -000LF Au FLASH -001LF 15μ"/0.38μ Au -002LF 6μ"/0.15μ Au REMAINDER: -000LF SEE NOTE 7 -001LF 15μ"/0.38μ Au -002LF Au FLASH	Au FLASH	.0035/0.089	18-20	48241	48250	NO	YES	NO	NO	NO	NO
			22-26	48242	48251	NO	YES	NO	NO	NO	NO
			28-32	48243	48252	NO	YES	NO	NO	NO	NO
		.0048/0.122	18-20	48244	48253	NO	YES	NO	NO	NO	NO
			22-26	48245	48254	NO	YES	NO	NO	NO	NO
			28-32	48246	48255	NO	YES	NO	NO	NO	NO
		.0065/0.165	18-20	48247	48256	NO	YES	NO	NO	NO	NO
			22-26	48248	48257	NO	YES	NO	NO	NO	NO
			28-32	48249	48258	NO	YES	NO	NO	NO	NO
CONTACT AREA UNDERPLATING: 50μ"/1.27μ Ni CONTACT AREA: 30μ"/0.76μ Au INSIDE BOX AREA: -000LF Au FLASH -001LF 30μ"/0.76μ Au -002LF 8μ"/0.2μ Au REMAINDER: -000LF SEE NOTE 7 -001LF 30μ"/0.76μ Au -002LF Au FLASH	Au FLASH	.0035/0.089	18-20	48231	48266	NO	YES	NO	NO	NO	NO
			22-26	48049	48235	NO	YES	NO	NO	NO	YES
			28-32	48048	48238	NO	YES	NO	NO	NO	YES
		.0048/0.122	18-20	48047	48232	NO	YES	NO	NO	NO	YES
			22-26	48046	48234	NO	YES	NO	NO	NO	YES
			28-32	48045	48237	NO	YES	NO	NO	NO	YES
		.0065/0.165	18-20	48052	48233	NO	YES	NO	NO	NO	YES*
			22-26	48051	48236	NO	YES	NO	NO	NO	YES
			28-32	48050	48239	NO	YES	NO	NO	NO	YES

* LOOSE PIECE NOT AVAILABLE

mat'l. code				surface <input checked="" type="checkbox"/> tolerance		projection		product family	
SEE TABLE								PV TERMINALS	
ltr	ecn no	dr	date	tolerances unless otherwise specified				title	
AN	V12-0006	HTB	12.01.05	angles	linear	INCH/MM		MINI PV™ RECEPTACLE	
AP	F-21694	AMA	15.08.18			SCALE 1:1		CRIMP TO WIRE	
				dr	A.MAISIERES	15.07.16		dwg no	
				engr	L.MULIN	15.07.16		sheet 3 of 5	
				chr				size	
				appd	L.MULIN	15.07.16		A3	
sheet index		revision sheet						type Product Customer Drawing	



Copyright FCJ

MATERIAL & PLATING		SPRING THICKNESS DIM H±.0005/0.012	AWG RANGE	REELED NOTE 4	LOOSE NOTE 4	PLATING AVAILABILITY					
1/4 HARD BRASS BODY	Be/Cu SPRING					-000	-000LF	-001	-001LF	-002	-002LF
CONTACT AREA UNDERPLATING: 50µ"/1.27µ Ni CONTACT AREA: 40µ"/1.02µ Au INSIDE BOX AREA: -000LF Au FLASH -001LF 8µ"/0.2µ Au -002LF 8µ"/0.2µ Au REMAINDER: -000LF SEE NOTE 7 -001LF 8µ"/0.2µ Au -002LF Au FLASH	Au FLASH	.0035/0.089	18-20	48276	N/A	NO	NO	NO	NO	NO	YES
			22-26	47457	47743	NO	YES	NO	YES	NO	YES
			28-32	47456	47742	NO	YES	NO	YES	NO	YES
		.0048/0.122	18-20	47441	47713	NO	YES	NO	YES	NO	YES
			22-26	47439	47712	NO	YES	NO	YES	NO	YES
			28-32	47437	47711	NO	YES	NO	YES	NO	YES
		.0065/0.165	18-20	47566	47746	NO	YES	NO	YES	NO	YES
			22-26	47565	47745	NO	YES	NO	YES	NO	YES
			28-32	47564	47744	NO	YES	NO	YES	NO	YES

DISCONTINUED				48191	48194						
DISCONTINUED				48192	48195						
DISCONTINUED				48193	48196						

CONTACT AREA UNDERPLATING: 50µ"/1.27µ Ni CONTACT AREA: 75µ"/1.91µ Au INSIDE BOX AREA: -000LF Au FLASH -001LF 75µ"/1.91µ Au -002LF 30µ"/0.76µ Au REMAINDER: -000LF SEE NOTE 7 -001LF 75µ"/1.91µ Au -002LF 15µ"/0.38µ Au	Au FLASH	.0035/0.089	18-20	47785	48014	NO	YES	NO	NO	NO	NO
		.0048/0.122	22-26	47216	47706	NO	YES	NO	NO	NO	NO
			28-32	47212	47705	NO	YES	NO	NO	NO	NO

mat'l. code SEE TABLE				surface <input checked="" type="checkbox"/> tolerance		projection		product family PV TERMINALS			
ltr ecn no dr date				tolerances unless otherwise specified				title			
AN V12-0006 HTB 12.01.05				angles linear .XX±.01/.X±.3		INCH/MM		MINI PV™ RECEPTACLE CRIMP TO WIRE			
AP F-21694 AMA 15.08.18				.XXX±.005/.XXX±.13		SCALE 1:1		dwg no sheet 4 of 5 size			
				dr A.MAISIERES 15.07.15				47212 A3			
				enr L.MULIN 15.07.15				type Product Customer Drawing			
				chr							
				appd L.MULIN 15.07.15							
sheet index		revision sheet									

MATERIAL & PLATING		SPRING THICKNESS DIM H±.0005/0.012	AWG RANGE	REELED NOTE 4	LOOSE NOTE 4	PLATING AVAILABILITY					
1/4 HARD BRASS BODY	Be/Cu SPRING					-000	-000LF	-001	-001LF	-002	-002LF
PRE-PLATED: -000LF 100-160μ" 2.54-4.06μ Sn (LEAD-FREE) NOTE 6	Sn PLATED	.0035/0.089	22-26	47445	47747	NO	YES	NO	NO	NO	NO
			28-32	47446	47748	NO	YES	NO	NO	NO	NO
		.0048/0.122	18-20	47221	47716	NO	YES	NO	NO	NO	NO
			22-26	47217	47715	NO	YES	NO	NO	NO	NO
			28-32	47213	47714	NO	YES	NO	NO	NO	NO
		.0065/0.165	18-20	47648	47749	NO	YES	NO	NO	NO	NO
			22-26	47649	47750	NO	YES	NO	NO	NO	NO
			28-32	47650	47751	NO	YES	NO	NO	NO	NO



FCIconnect.com

Copyright FCI

mat'l. code				surface <input checked="" type="checkbox"/> tolerance		projection		product family				
SEE TABLE								PV TERMINALS				
ltr	ecn no	dr	date	tolerances unless otherwise specified				title				
AN	V12-0006	HTB	12.01.05	angles		.XX±.01/.X±.3		INCH/MM		MINI PV™ RECEPTACLE		
AP	F-21694	AMA	15.08.18	linear		.XXX±.005/.XXX±.13		scale 1:1		CRIMP TO WIRE		
						.XXXX±.0020/.XXX±.05				dwg no		
				dr	A.MAISIERES	15.07.15				sheet 5 of 5 size		
				engr	L.MULIN	15.07.15				47212		A3
				chr								
				appd	L.MULIN	15.07.15						
sheet index		revision sheet								type Product Customer Drawing		