

Ultrasonic retro-reflective sensors

U500.RA0.2-11200634

dimension drawing

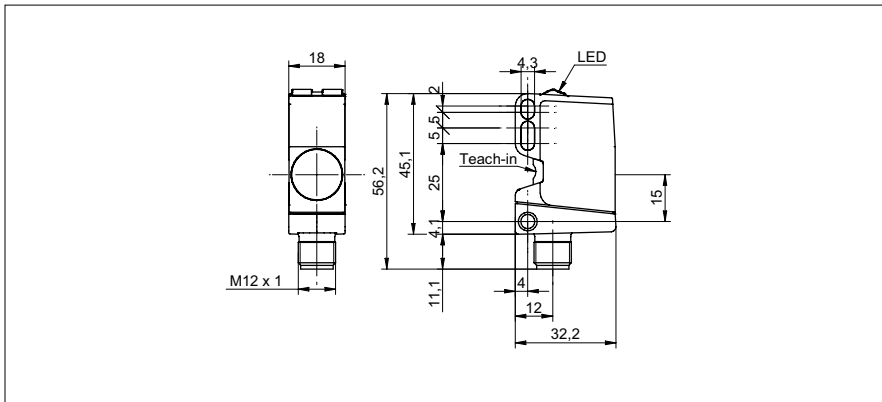

general data

scanning range Sd	0 ... 1000 mm
reflector position Sde	100 ... 1000 mm
adjusting range reflector (operating range)	± 2,5 % Sde
adjusting range reflector (limit range)	± 5 % Sde
version	IO-Link
repeat accuracy	< 0,5 mm
temperature drift	< 2 % Sde
power-up drift	compensated after 15 min.
response time ton	< 40 ms
release time toff	< 40 ms
sonic frequency	200 kHz
adjustment	qTeach, line-Teach, IO-Link
alignment aid	light indicator flashing
light indicator	LED yellow
power on indication	LED green
alignment measuring axis	< 2°

electrical data

voltage supply range +Vs	12 ... 30 VDC
current consumption typ.	35 mA
output circuit	push-pull
output current	< 100 mA
voltage drop Vd	< 3,5 VDC
residual ripple	< 10 % Vs
short circuit protection	yes
reverse polarity protection	yes

mechanical data

type	rectangular
housing material	plastic (ASA, PMMA)
width / diameter	18 mm
height / length	45 mm
depth	32 mm
connection types	connector M12 5 pin
coating active face	PEEK

photo



connection diagram

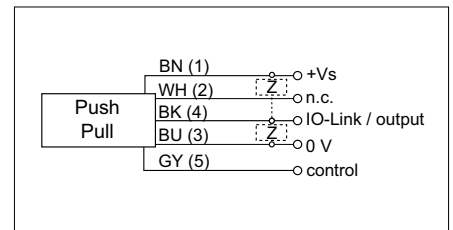

Ultrasonic retro-reflective sensors

U500.RA0.2-11200634

ambient conditions

operating temperature	-25 ... +65 °C
storage temperature	-40 ... +75 °C
protection class	IP 67

communications interface

interface	IO-Link V1.1
baud rate	38,4 kBaud (COM 2)
cycle time	≥ 10 ms
process data length	32 Bit
process data structure	Bit 0 = SSC1 (distance) Bit 1 = SSC2 (distance) Bit 2 = quality Bit 3 = alarm Bit 5 = SSC4 (counter) Bit 8-15 = scale factor Bit 16-47 = 32 Bit measurement

IO-Link port type Class A

additional data	distance excess gain operating cycles operating hours boot cycles operating voltage device temperature histograms
adjustable parameters	time filters LED status indicators output logic output circuit counter beam forming deactivate the sensor element Find Me function

typical sonic cone profile

