

Inside Face to Face Dimension
ASSEMBLY - VIEW FROM TOP

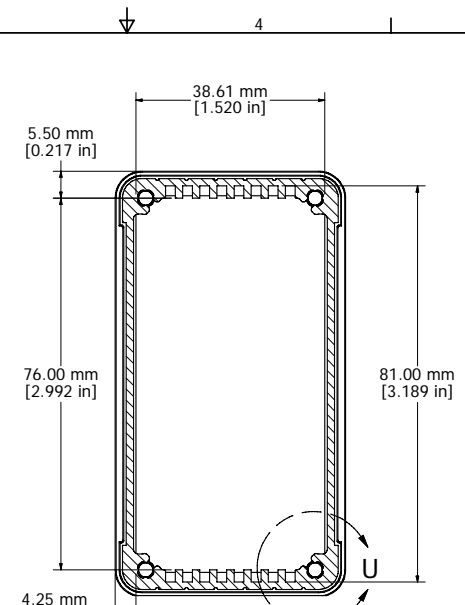

SECTION T-T

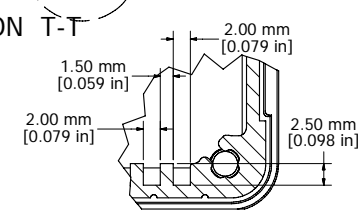

DETAIL U

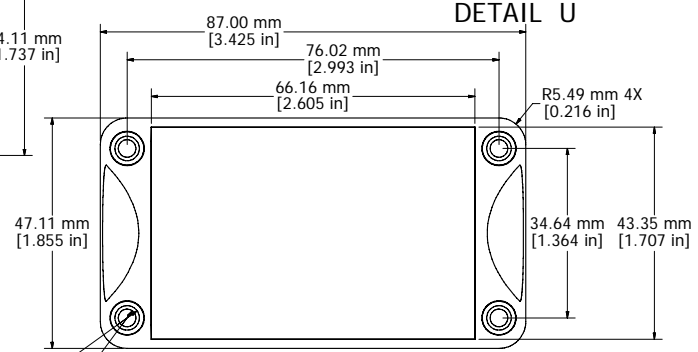
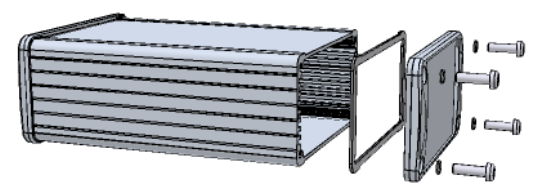

END PANEL - VIEW FROM OUTSIDE

$\varnothing 5.00 \text{ mm} \nabla 0.60 \text{ mm} \text{ 4X}$
 $\varnothing 3.60 \text{ mm} \nabla 8.00 \text{ mm}$
 $\llcorner \varnothing 7.00 \text{ mm} \nabla 2.50 \text{ mm} \text{ 4X}$

Fits 120mm (4.724") X 80mm (3.149") PCB
Note: Aluminum extrusion has a tolerance of $-/+ .02"$

PROTECTION TO IP 65

Enclosures can be Factory Modified (Milling, Drilling, Printing etc.)
Contact Factory mjm@hammondmfg.com for quotes
Solid models of this enclosure available in STEP or IGES.

NOTE	
Purchased assembly includes box, end panels, stainless steel #6 Taptight screws, self adhesive rubber feet, gaskets and O-Rings.	
Box made from Extruded Aluminum 6063.	
End panels made from Type 380 Diecast Aluminum with a black powder paint finish.	
WATERPROOF 1457K1201	
PART NUMBERS	
Clear anodized box with black powder painted end panels	1457K1201
Black powder painted box and end panels	1457K1201BK
EMI/RFI SHIELDED (IP 54)	
Clear anodized box with black powder painted end panels	1457K1201E
Black powder painted box and end panels	1457K1201BKE
ACCESSORIES	
See website for accessories.	

HAMMOND MANUFACTURING™
1457K1201
www.hammondmfg.com