

ECO.100S+/TD

Kernboormachine

EUROBOOR

FOR PROFESSIONALS BY PROFESSIONALS

Technische data

	Metrisch	Imperisch
Kernboren	Ø 12 - 120 mm	Ø 1/2" - 4 3/4"
Spiraalboren	Ø 1 - 31,75 mm	Ø 1/16" - 1 1/4"
Verzinken	Ø 10 - 105 mm	Ø 3/8" - 4 1/8"
Tappen	M3 - M30	Ø 1/8" - 1 3/16"
<hr/>		
Lengte	365 mm	14 3/8"
Breedte	310 mm	12 3/16"
Hoogte	515 - 715 mm	20 1/4" - 28 1/8"
<hr/>		
Slag	260 mm	10 1/4"
Gewicht*	31 kg	68,3 lbs
Magneet (l x b x h)	220 x 110 x 64 mm	8 11/16" x 4 5/16" x 2 1/2"
Magnetische kracht	3.000 kg	6.615 lbs
Motor vermogen	1.900 W	17,3 A
Totaal vermogen	2.050 W	18,6 A
<hr/>		
Toerental (onbelast)		(I) 42 - 110 tpm (II) 65 - 190 tpm (III) 140 - 400 tpm (IV) 220 - 620 tpm
Toerental (belast 1.900 W, 17,3 A)		(I) 85 tpm (II) 152 tpm (III) 270 tpm (IV) 480 tpm
<hr/>		
Opname (Weldon)	MT3 19,05 mm	MT3 3/4"
Krachtvoorziening	110 - 120 V / 60 Hz 220 - 240 V / 50 - 60 Hz	

* Zonder stroomkabel en hendels

Kenmerken

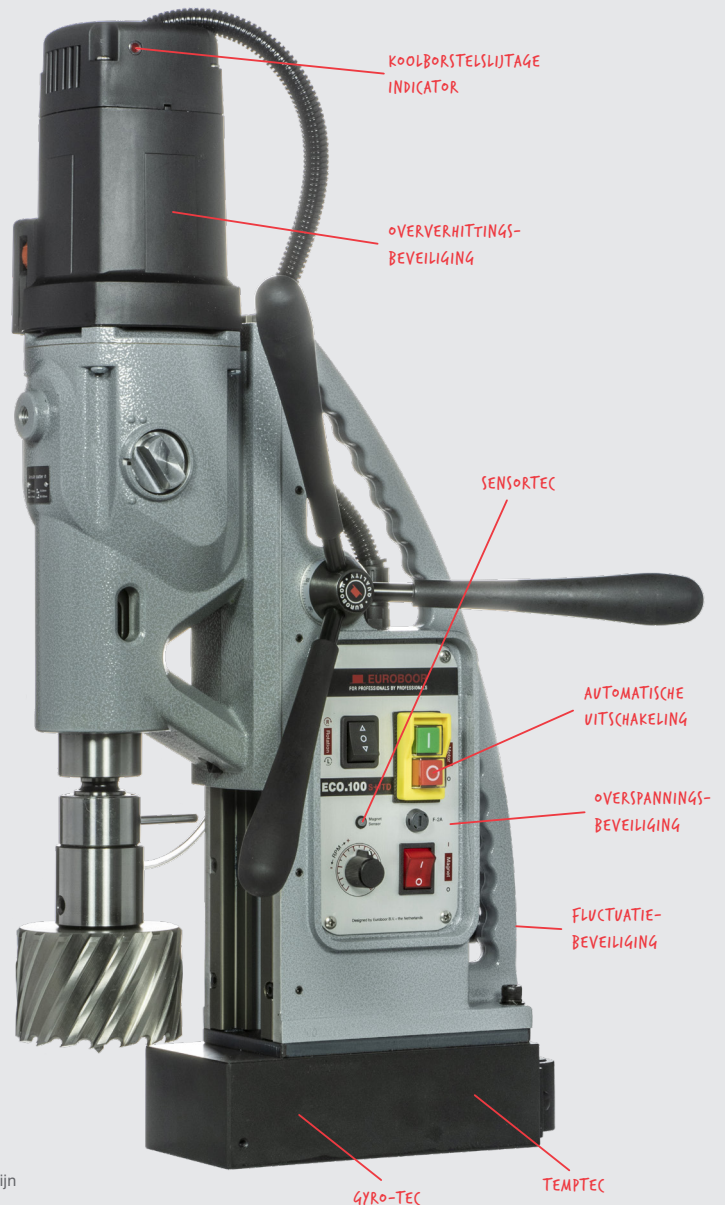
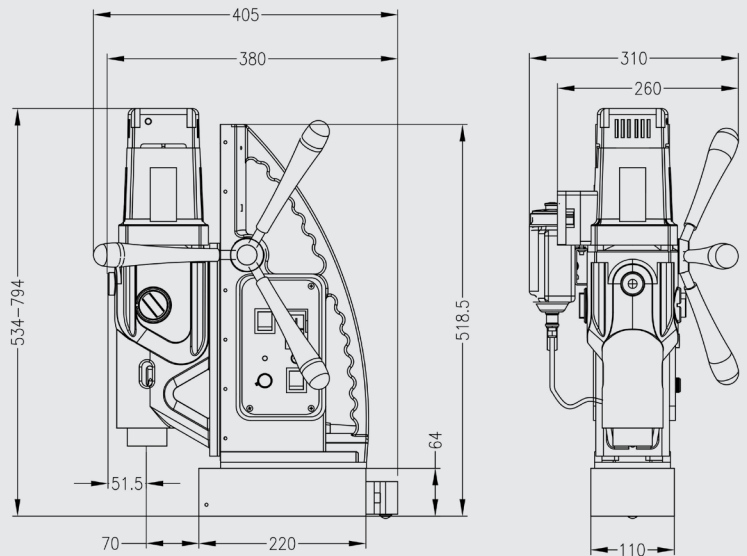
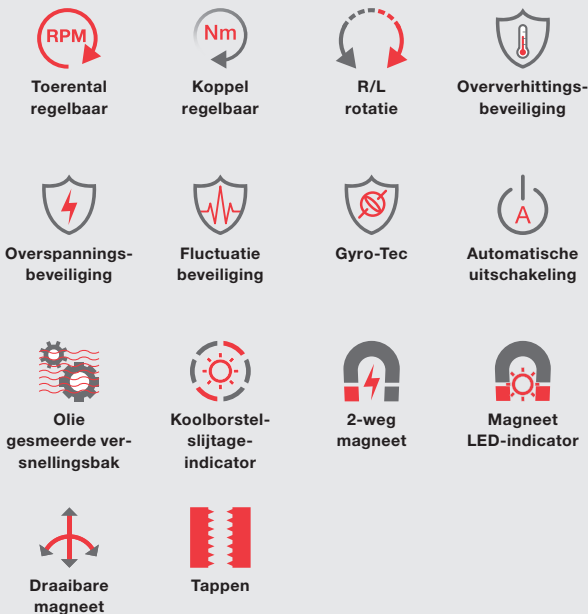

Euroboor stelt alles in het werk om te voldoen aan kwaliteits- en integriteitseisen. Daarom zijn wij als organisatie trots op de erkenning van enkele toonaangevende instanties wereldwijd:



www.euroboor.com