

Product Data Sheet RG125-19/14N/2

ebmpapst

The engineer's choice



RG125-19/14N/2

INDEX

1	General	3
2	Mechanics	3
2.1	General.....	3
2.2	Connections.....	3
3	Operating Data	5
3.1	Electrical Operating Data	5
3.2	Operating Data - Electrical Interface - Output	6
3.3	Electrical Features.....	7
3.4	Aerodynamics.....	8
3.5	Sound Data.....	9
4	Environment	9
4.1	General.....	9
4.2	Climatic Requirements	9
5	Safety	10
5.1	Electrical Safety.....	10
5.2	Approval Tests	10
6	Reliability	10
6.1	General.....	10

1 General

Fan type	Blower	
Rotating direction looking at rotor	Clockwise	
Airflow direction	Air in axially, Air out radially	
Bearing system	Ball bearing	
Mounting position - shaft	Any	

2 Mechanics

2.1 General

Width	180,0 mm	
Height	180,0 mm	
Depth	40,0 mm	
Mass	0,750 kg	
Housing material	Mixed	
Impeller material	Mixed	
Max. torque when mounted across both mounting flanges; Metal flange on mounting plate	Wire outlet corner: 70 Ncm Remaining corners: 70 Ncm	
Screw size	ISO 4762 - M4 degreased, without an additional brace and without washer	

2.2 Connections

Electrical connection	Wires	
Lead wire length	L = 310 mm	
Tolerance	+/- 10,0 mm	
Tube length	S = 20 mm	
Tolerance	+/- 10,0 mm	
Wire size (AWG)	22	
Insulation diameter	1,70 mm	

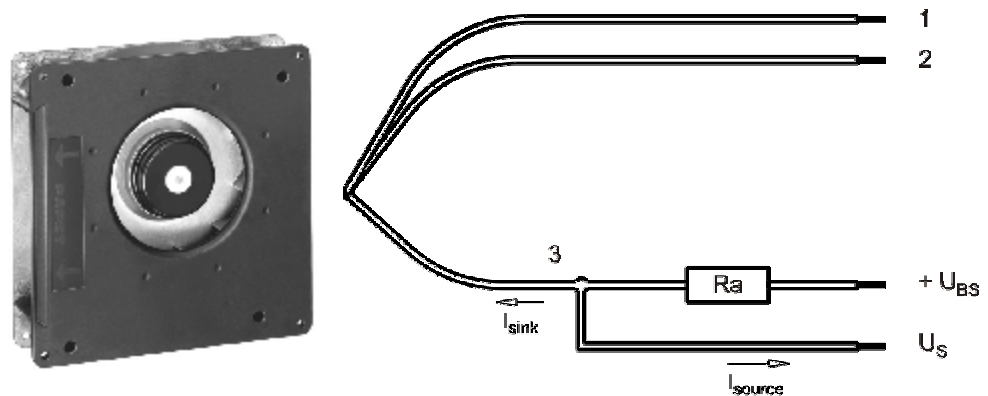

Wire	Color	Operation
1	red	+ UB
2	black	- GND
3	yellow	Tacho

The auxiliaries shown on the schematic diagram (which are required for the intended use) are not part of our delivery.

3 Operating Data

3.1 Electrical Operating Data

Measurement conditions: Normal air density = 1,2 kg/m³; Temperature 23°C +/- 3°C; Motor axis horizontal; warm-up time before measuring 5 minutes (unless otherwise specified). In the intake and outlet area should not be any solid obstruction within 0,5 m.

$\Delta p = 0$: corresp. to free air flow (see section 3.5)
I: corresp. to arithm. mean current value

Features	Condition	Symbol	Values		
Voltage range		U	12,0 V		28,0 V
Nominal voltage		U_N		24,0 V	
Power consumption	$\Delta p = 0$	P	1,1 W	4,9 W	6,7 W
Tolerance	0010		+/- 17,5 %	+/- 12,5 %	+/- 15,0 %
Current consumption	$\Delta p = 0$	I	94 mA	203 mA	240 mA
Tolerance	0010		+/- 17,5 %	+/- 12,5 %	+/- 15,0 %
Speed	$\Delta p = 0$	n	1.365 1/min	2.550 1/min	2.840 1/min
Tolerance	0010		+/- 12,5 %	+/- 7,5 %	+/- 10,0 %
Starting current consumption				< 900 mA	

3.2 Operating Data - Electrical Interface - Output

Tacho type	/2 (open collector)
------------	---------------------

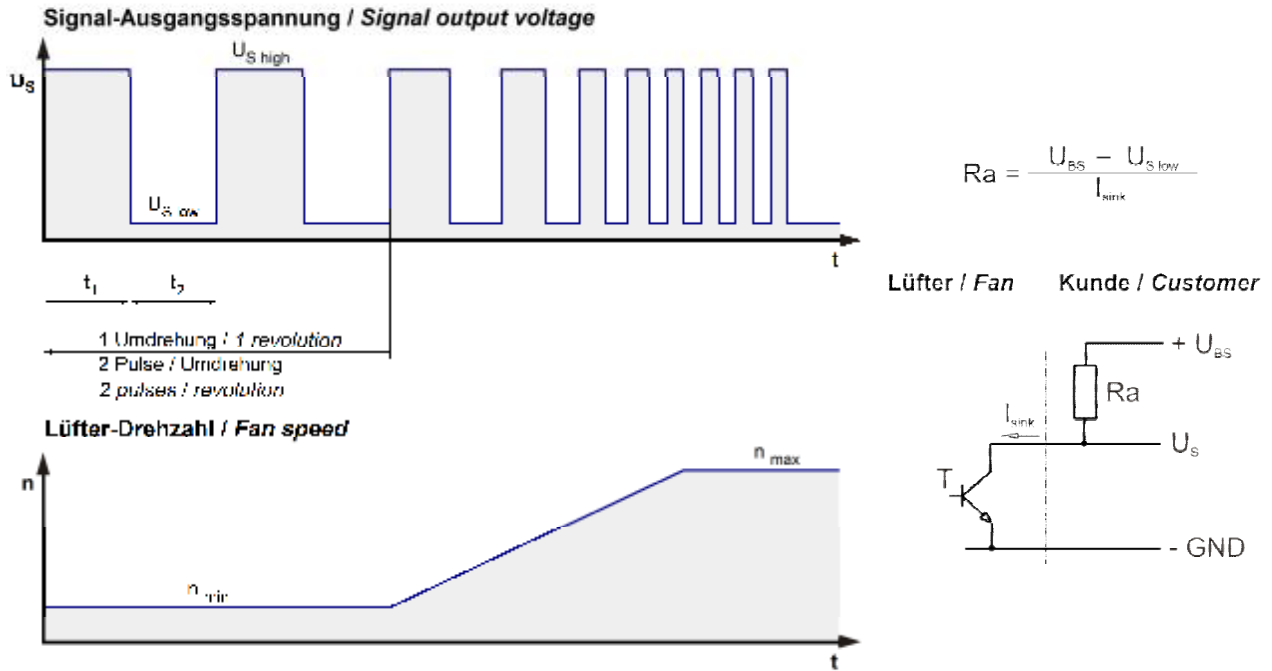

Features	Note	Values
Tacho operating voltage	U_{BS}	Min.: 4 V Max.: 30 V
Tacho signal Low	$U_{S,low}$	$I_{sink}: 2 \text{ mA}$ $\leq 0,4 \text{ V}$
Tacho signal High	$U_{S,high}$	$I_{source}: 0 \text{ mA}$ 30,0 V
Maximum sink current	I_{sink}	$\leq 4 \text{ mA}$
External resistor	External resistor R_a from U_{BS} to U_S required. All voltages measured to GND.	
Tacho frequency	$(2 \times n) / 60$	
Tacho isolated from motor	No	
Slew rate		$\Rightarrow 0,5 \text{ V/us}$

n = revolutions per minute (1/min)

3.3 Electrical Features

Electronic function	None	
Reversed polarity protection	Rectifying diode	
Max. residual current at U_N	$I_F \leq 10 \text{ mA}$	
Locked rotor protection	Auto restart	
Locked rotor current at U_N	I_{block} approx. 900 mA	
Clock signal at locked rotor	t_3 / t_4 typical: 0,6 s / 10 s	

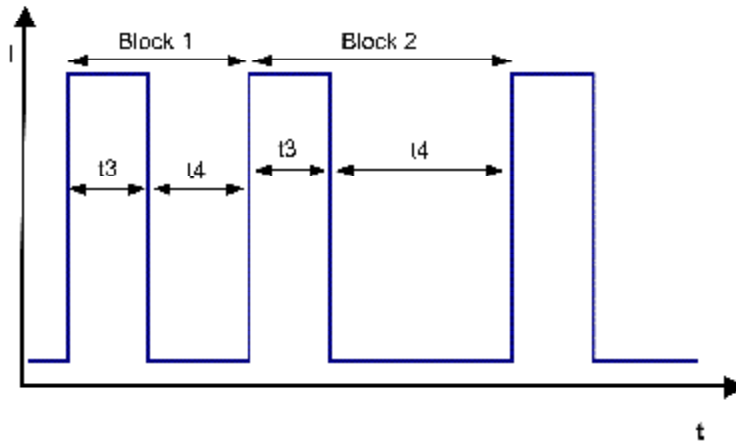

Block1: special locked rotor protection: 5 cycles $t_3 / t_4 = 0,6 \text{ s} / 1 \text{ s}$ Block2: locked rotor protection $t_3 / t_4 = 0,6 \text{ s} / 10 \text{ s}$

3.4 Aerodynamics

Measurement conditions: Measured with a double chamber intake rig acc. to DIN EN ISO 5801.
 Normal air density = 1,2 kg/m³; Temperature 23°C +/- 3°C;
 In the intake and outlet area should not be any solid obstruction within 0,5 m.
 The information is only valid under the specified test conditions and may be changed by the installation conditions. If there are deviations from the standard test conditions, the characteristic values must be checked under the installed conditions.

a.) Operation condition:

2.550 1/min at free air flow

Max. free-air flow ($\Delta p = 0 / \dot{V} = \text{max.}$)	88,0 m ³ /h	
Max. static pressure ($\Delta p = \text{max.} / \dot{V} = 0$)	180 Pa	

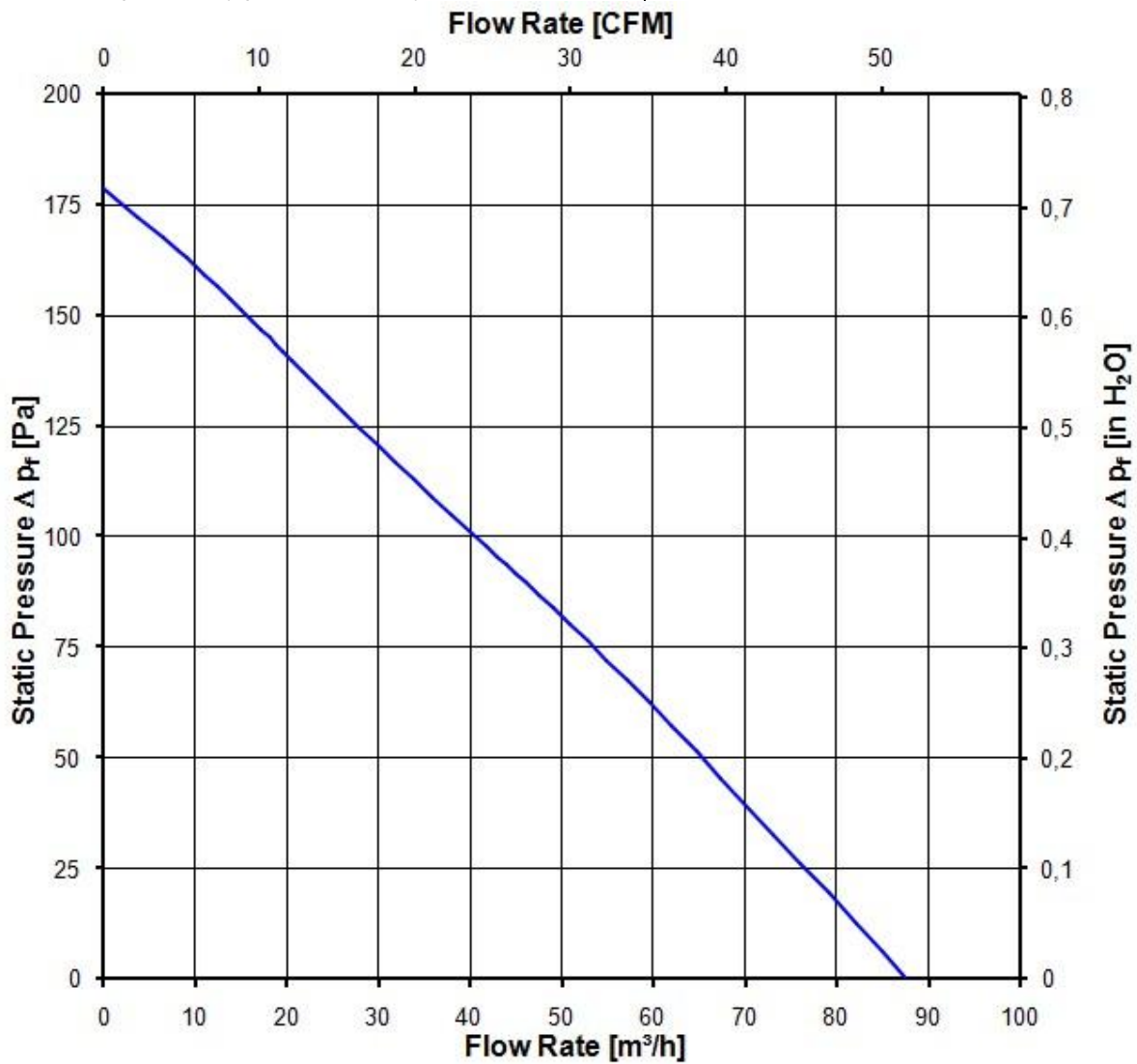

3.5 Sound Data

Measurement conditions: Sound pressure level: 1 meter distance between microphone and the air intake.
 Sound power level: Acc. to DIN 45635 part 38 (ISO 10302)
 Measured in a semianchoic chamber with a background noise level of $L_p(A) < 5 \text{ dB}(A)$
 For further measurement conditions see section 3.5

a.) Operation condition:

2.550 1/min at free air flow

Optimal operating point	10,0 m ³ /h @ 144 Pa	
Sound power level at the optimal operating point	5,7 bel(A)	
Sound pressure level at free air flow, measured in rubber bands		

4 Environment

4.1 General

Min. permitted ambient temperature TU min.	-30 °C	
Max. permitted ambient temperature TU max.	75 °C	
Min. permitted storage temperature TL min.	-40 °C	
Max. permitted storage temperature TL max.	80 °C	

4.2 Climatic Requirements

Humidity requirements	humid heat, constant; according to DIN EN 60068-2-78, 14 days	
Water exposure	None	
Dust requirements	None	
Salt fog requirements	None	

Permitted application area:

The product is intended for use in sheltered rooms with controlled temperature and controlled humidity. Directly exposure to water must be avoided.

Pollution degree 1 (according DIN EN 60664-1)

There is either no pollution or it occurs only dry, non-conductive pollution. The pollution has no negative impact.

Please require severity levels and specification parameters from the responsible development departments.

5 Safety

5.1 Electrical Safety

Dielectric strength DIN EN 60950 (VDE 0805) and DIN EN 60335 (VDE 0700) A.) Type test Measuring conditions: After 48h of storage at 95% R.H. and 25°C. No arcing or breakdown is allowed! All connections together to ground.	500 VAC / 1 Min.	
B.) Routine test Measuring conditions: At indoor climate. No arcing or breakdown is allowed! All connections together to ground.	500 VAC / 1 Sec.	
Isolation resistance Measuring conditions: After 48h of storage at 95% R.H. and 25°C measured with U=500 VDC for 1 min.	RI > 10 MOhm	
Clearance / creepage distance	1,0 mm / 1,2 mm	
Protection class	III	

5.2 Approval Tests

CE	EC Declaration of Conformity	Yes
EAC	Eurasian Conformity	Yes
UL	Underwriters Laboratories	Yes / UL audited by CSA according to UL507, Electric Fans
VDE	Association for Electrical, Electronic and Information Technologies	Yes / Approval acc. to EN 60950 (VDE 0805) - Information technology equipment
CSA	Canadian Standards Association	Yes / C22.2 No. 113 Fans and Ventilators
CCC	China Compulsory Certification	Not applicable

6 Reliability

6.1 General

Life expectancy L10 at TU = 40 °C	62.500 h	
Life expectancy L10 at TU max.	27.500 h	
Life expectancy L10 acc. to IPC 9591 at TU = 40 °C	105.000 h	

Copying of this document and using it in other and the use or communication of
 the contents thereof, are prohibited without express written permission. Offenders are liable to
 the payment of damages. All rights are reserved in the event of the grant of a
 patent or the registration of a utility model or design.

Schutzmerkmal nach DIN 24 beachten

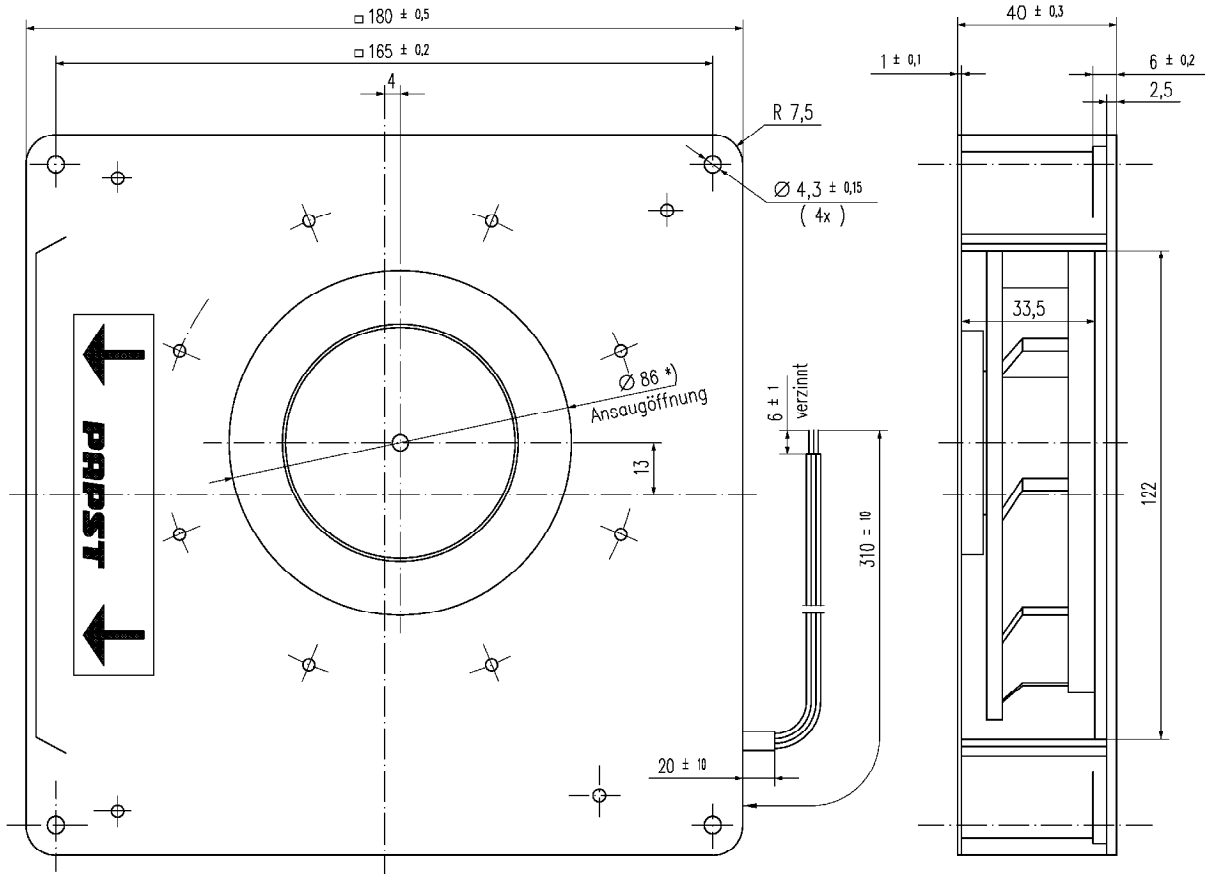

gilt für:

959 4310 131	RG125-19/14N/17
959 4310 132	RG125-19/14N/2
959 4310 133	RG125-19/14N/2-133
959 4310 134	RG125-19/14N/12
959 4310 135	RG125-19/12N/12
959 4310 136	RG125-19/14N/17H-136
① 959 4310 137	RG125-19/14N/2-137
② 959 4310 139	RG125-19/18N/2

516
 210
 232
 235
 240
 082

*) Öffnung für Montagewand ≥ 100 mm
 Axialspiel: 0 (mit Federausgleich)

Allgemeintoleranzen				ISO 2768 - m			
g	f	e	d	Datum	Name	Artikel	Meßstab
				Erstellt			
				Gesprüft			
Index	Änd.-Nr.	Datum	Geändert von	PAPST		Zchg.-Nr.	Blatt
Zur Verwendung im Verteiler freigegeben von				PAPST-MOTOREN GmbH & Co KG D-78112 St. Georgen Germany		Ers.f.Zchg.:	Ä