

Quad Supply Voltage Supervisor with Adjustable Delay and Watchdog Timer

Check for Samples: [TPS386000](#), [TPS386020](#), [TPS386040](#), [TPS386060](#)

FEATURES

- Four Independent Voltage Supervisors
- Channels 1, 2, 3: Adjustable Threshold Down to 0.4V
- Channel 4: Adjustable Threshold at Any Positive/Negative Voltage
- Adjustable Delay Time: 1.4ms to 10s
- Threshold Accuracy: 0.25% typ
- Very Low Quiescent Current: 11µA typ
- Channel 1: Manual Reset (\overline{MR}) Input
- Channel 4: Window Comparator
- Watchdog Timer with Dedicated Output
- Well-Controlled Output During Power-Up
- TPS386000: Open-Drain \overline{RESETn} and \overline{WDO}
- TPS386020: Open-Drain \overline{RESETn} and \overline{WDO}
- TPS386040: Push-Pull \overline{RESETn} and \overline{WDO}
- TPS386060: Push-Pull \overline{RESETn} and \overline{WDO}
- Package: 4mm x 4mm, 20-pin QFN

APPLICATIONS

- All DSP and Microcontroller Applications
- All FPGA/ASIC Applications
- Telecom/Wireless Infrastructure
- Industrial Equipment
- Analog Sequencing

DESCRIPTION

The TPS3860x0 family of supply voltage supervisors (SVSs) can monitor four power rails that are greater than 0.4V and one power rail less than 0.4V (including negative voltage) with a 0.25% (typical) threshold accuracy. Each of the four supervisory circuits (SVS-n) assert a \overline{RESETn} or \overline{RESETn} output signal when the SENSEm input voltage drops below the programmed threshold. With external resistors, the threshold of each SVS-n can be programmed (where $n = 1, 2, 3, 4$ and $m = 1, 2, 3, 4L, 4H$).

Each SVS-n has a programmable delay before releasing \overline{RESETn} or \overline{RESETn} . The delay time can be set independently for each SVS from 1.4ms to 10s through the CTn pin connection. Only SVS-1 has an active-low manual reset (\overline{MR}) input; a logic-low input to \overline{MR} asserts $\overline{RESET1}$ or $\overline{RESET1}$.

SVS-4 monitors the threshold window using two comparators. The extra comparator can be configured as a fifth SVS to monitor negative voltage with voltage reference output VREF.

The TPS3860x0 has a very low quiescent current of 11µA (typical) and is available in a small, 4mm x 4mm, QFN-20 package.

TPS386000 Typical Application Circuit

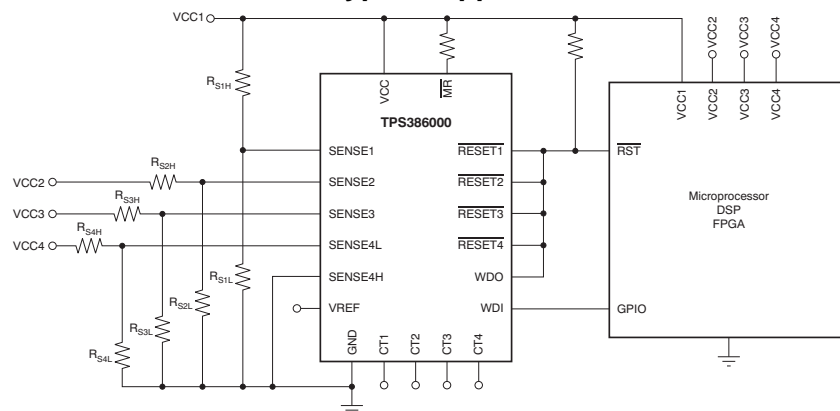

Please be aware that an important notice concerning availability, standard warranty, and use in critical applications of Texas Instruments semiconductor products and disclaimers thereto appears at the end of this data sheet.

All trademarks are the property of their respective owners.



This integrated circuit can be damaged by ESD. Texas Instruments recommends that all integrated circuits be handled with appropriate precautions. Failure to observe proper handling and installation procedures can cause damage.

ESD damage can range from subtle performance degradation to complete device failure. Precision integrated circuits may be more susceptible to damage because very small parametric changes could cause the device not to meet its published specifications.

ORDERING INFORMATION⁽¹⁾

PRODUCT	DESCRIPTION
TPS3860x0yyyz	<p>x is device configuration option x = 0: Open-drain, active low x = 2: Open-drain, active high x = 4: Push-pull, active low x = 6: Push-pull, active high yyy is package designator z is package quantity</p>

(1) For the most current package and ordering information see the Package Option Addendum at the end of this document, or see the TI web site at www.ti.com.

ABSOLUTE MAXIMUM RATINGS⁽¹⁾

Over operating junction temperature range, unless otherwise noted.

	TPS3860x0	UNIT
Input voltage range, V_{VCC}	-0.3 to 7.0	V
CT pin voltage range, V_{CT1} , V_{CT2} , V_{CT3} , V_{CT4}	-0.3 to $V_{VCC} + 0.3$	V
Other voltage ranges: V_{RESET1} , V_{RESET2} , V_{RESET3} , V_{RESET4} , V_{MR} , V_{SENSE1} , V_{SENSE2} , V_{SENSE3} , $V_{SENSE4L}$, $V_{SENSE4H}$, V_{WDI} , V_{WDO}	-0.3 to 7.0	V
$\overline{RESE\bar{T}n}$, $RESE\bar{T}n$, \overline{WDO} , WDO , V_{REF} pin current	5	mA
Continuous total power dissipation	See Dissipation Ratings Table	
Operating virtual junction temperature range, T_J ⁽²⁾	-40 to +150	°C
Operating ambient temperature range	-40 to +125	°C
Storage temperature range, T_{STG}	-65 to +150	°C
ESD rating	Human body model (HBM)	2 kV
	Charged device model (CDM)	500 V

- (1) Stresses beyond those listed under the *Absolute Maximum Ratings* may cause permanent damage to the device. These are stress ratings only, and functional operation of the device at these or any other conditions beyond those indicated under the recommended operating conditions is not implied. Exposure to absolute maximum rated conditions for extended periods may affect device reliability.
- (2) As a result of the low dissipated power in this device, it is assumed that $T_J = T_A$.

DISSIPATION RATINGS

PACKAGE	$T_A < +25^\circ\text{C}$ POWER RATING	DERATING FACTOR ABOVE $T_A > +25^\circ\text{C}$	$T_A = +70^\circ\text{C}$ POWER RATING	$T_A = +85^\circ\text{C}$ POWER RATING
RGP	2.86W	28.6mW/°C	1.57W	1.24W

ELECTRICAL CHARACTERISTICS

Over the operating temperature range of $T_J = -40^\circ\text{C}$ to $+125^\circ\text{C}$, $1.8\text{V} < V_{\text{VCC}} < 6.5\text{V}$, $R_{\text{RESET}n}$ ($n = 1, 2, 3, 4$) = $100\text{k}\Omega$ to V_{VCC} (TPS386000, TPS386020 only), $C_{\text{RESET}n}$ ($n = 1, 2, 3, 4\text{L}, 4\text{H}$) = 50pF to GND , $R_{\text{WDO}} = 100\text{k}\Omega$ to V_{VCC} , $C_{\text{WDO}} = 50\text{pF}$ to GND , $V_{\text{MR}} = 100\text{k}\Omega$ to V_{VCC} , $\text{WDI} = \text{GND}$, and $\text{CT}n$ ($n = 1, 2, 3, 4$) = open, unless otherwise noted. Typical values are at $T_J = +25^\circ\text{C}$.

PARAMETER		TEST CONDITIONS	MIN	TYP	MAX	UNIT		
V_{VCC}	Input supply range		1.8		6.5	V		
I_{VCC}	Supply current (current into VCC pin)	$V_{\text{VCC}} = 3.3\text{V}$, $\overline{\text{RESET}n}$ or $\text{RESET}n$ not asserted, WDI toggling ⁽¹⁾ , no output load, and VREF open		11	19	μA		
		$V_{\text{VCC}} = 6.5\text{V}$, $\overline{\text{RESET}n}$ or $\text{RESET}n$ not asserted, WDI toggling ⁽¹⁾ , no output load, and VREF open		13	22	μA		
	Power-up reset voltage ⁽²⁾⁽³⁾	TPS386000, TPS386040	$V_{\text{OL}} (\text{max}) = 0.2\text{V}$, $I_{\text{RESET}n} = 15\mu\text{A}$		0.9	V		
V_{ITN}	Negative-going input threshold voltage	SENSE1, SENSE2, SENSE3, SENSE4L	396	400	404	mV		
V_{ITP}	Positive-going input threshold voltage	SENSE4H	396	400	404	mV		
V_{HYSN}	Hysteresis (positive-going) on V_{ITN}	SENSE1, SENSE2, SENSE3, SENSE4L		3.5	10	mV		
$V_{\text{HYS P}}$	Hysteresis (negative-going) on V_{ITP}	SENSE4H		3.5	10	mV		
I_{SENSE}	Input current at SENSEm pin	$V_{\text{SENSE}m} = 0.42\text{V}$	-25	± 1	+25	nA		
I_{CT}	CTn pin charging current	CT1	$C_{\text{CT}1} > 220\text{pF}$, $V_{\text{CT}1} = 0.5\text{V}^{(4)}$		245	300	355	nA
		CT2, CT3, CT4	$C_{\text{CT}n} > 220\text{pF}$, $V_{\text{CT}n} = 0.5\text{V}^{(4)}$		235	300	365	nA
$V_{\text{TH(CT}n)}$	CTn pin threshold	$C_{\text{CT}n} > 220\text{pF}$	1.180	1.238	1.299	V		
V_{IL}	$\overline{\text{MR}}$ and WDI logic low input		0		$0.3V_{\text{VCC}}$	V		
V_{IH}	$\overline{\text{MR}}$ and WDI logic high input		$0.7V_{\text{VCC}}$			V		
V_{OL}	Low-level $\overline{\text{RESET}n}$ or $\text{RESET}n$ output voltage	All	$I_{\text{OL}} = 1\text{mA}$			0.4	V	
		TPS386000, TPS386040	$\text{SENSE}n = 0\text{V}$, $1.3\text{V} < V_{\text{VCC}} < 1.8\text{V}$, $I_{\text{OL}} = 0.4\text{mA}^{(2)}$			0.3	V	
	Low-level WDO output voltage	All	$I_{\text{OL}} = 1\text{mA}$			0.4	V	
		TPS386020, TPS386060	$\text{SENSE}n = 0\text{V}$, $1.3\text{V} < V_{\text{VCC}} < 1.8\text{V}$, $I_{\text{OL}} = 0.4\text{mA}^{(2)}$			0.3	V	
V_{OH}	High-level $\overline{\text{RESET}n}$ or $\text{RESET}n$ output voltage	TPS386040, TPS386060	$I_{\text{OL}} = -1\text{mA}$		$V_{\text{VCC}} - 0.4$		V	
		TPS386060	$\text{SENSE}n = 0\text{V}$, $1.3\text{V} < V_{\text{VCC}} < 1.8\text{V}$, $I_{\text{OL}} = -0.4\text{mA}^{(2)}$		$V_{\text{VCC}} - 0.3$		V	
	High-level WDO output voltage	TPS386040, TPS386060	$I_{\text{OL}} = -1\text{mA}$		$V_{\text{VCC}} - 0.4$		V	
		TPS386040	$\text{SENSE}n = 0\text{V}$, $1.3\text{V} < V_{\text{VCC}} < 1.8\text{V}$, $I_{\text{OL}} = -0.4\text{mA}^{(2)}$		$V_{\text{VCC}} - 0.3$		V	
I_{LKG}	$\overline{\text{RESET}n}$, $\text{RESET}n$, $\overline{\text{WDO}}$, and WDO leakage current	TPS386000, TPS386020	$V_{\text{RESET}n} = 6.5\text{V}$, $\overline{\text{RESET}n}$, $\text{RESET}n$, $\overline{\text{WDO}}$, and WDO are logic high		-300	300	nA	
V_{REF}	Reference voltage output		$1\mu\text{A} < I_{\text{VREF}} < 0.2\text{mA}$ (source only, no sink)		1.18	1.20	1.22	V
C_{IN}	Input pin capacitance	CTn: 0V to V_{VCC} , other pins: 0V to 6.5V		5		pF		
t_{W}	Input pulse width to SENSEm and $\overline{\text{MR}}$ pins	SENSEm: $1.05V_{\text{ITN}} \rightarrow 0.95V_{\text{ITN}}$ or $0.95V_{\text{ITP}} \rightarrow 1.05V_{\text{ITP}}$		4		μs		
		$\overline{\text{MR}}$: $0.7V_{\text{VCC}} \rightarrow 0.3V_{\text{VCC}}$		1		ns		
t_{D}	$\overline{\text{RESET}n}$ or $\text{RESET}n$ delay time	CTn = open	14	20	24	ms		
		CTn = V_{VCC}	225	300	375	ms		
t_{WDT}	Watchdog timer timeout period	Start from $\overline{\text{RESET}1}$ or $\text{RESET}1$ release or last WDI transition	450	600	750	ms		

- (1) Toggling WDI for a period less than t_{WDT} negatively affects I_{VCC} .
- (2) These specifications are beyond the recommended V_{VCC} range, and only define $\overline{\text{RESET}n}$ or $\text{RESET}n$ output performance during VCC ramp up.
- (3) The lowest supply voltage (V_{VCC}) at which $\overline{\text{RESET}n}$ or $\text{RESET}n$ becomes active; $t_{\text{RISE}}(\text{VCC}) \geq 15\mu\text{s}/\text{V}$.
- (4) CTn (where $n = 1, 2, 3$, or 4) are constant current charging sources working from a range of 0V to $V_{\text{TH(CT}n)}$, and the device is tested at $V_{\text{CT}n} = 0.5\text{V}$. For I_{CT} performance between 0V and $V_{\text{TH(CT}n)}$, see [Figure 25](#).

PIN CONFIGURATIONS

RGP PACKAGE QFN-20 (TOP VIEW)

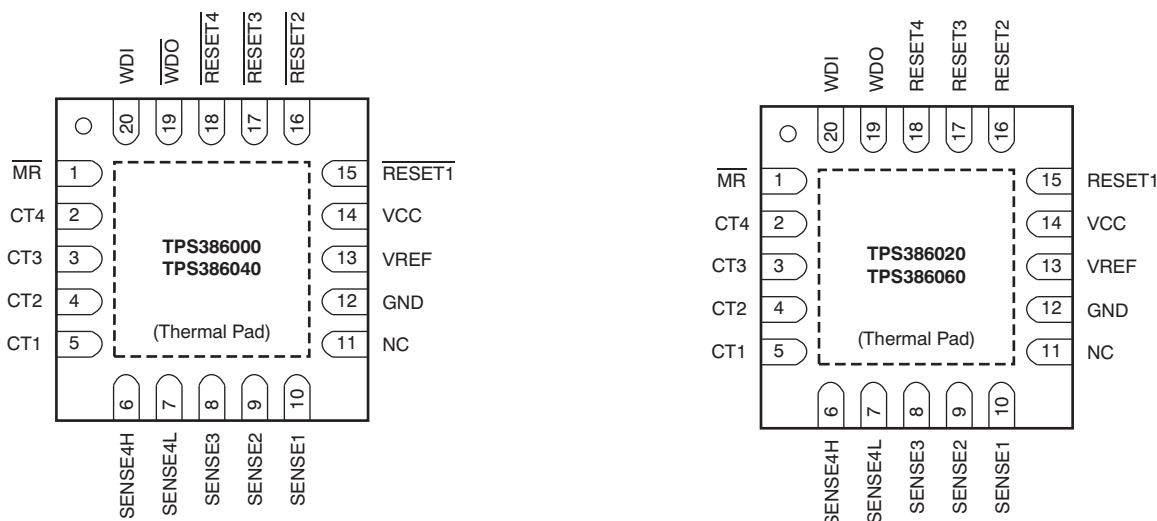

PIN ASSIGNMENTS

PIN		DESCRIPTION	
NAME	NO.		
VCC	14	Supply voltage. Connecting a 0.1µF ceramic capacitor close to this pin is recommended.	
GND	12	Ground	
SENSE1	10	Monitor voltage input to SVS-1	When the voltage at this terminal drops below the threshold voltage (V_{ITN}), RESET1 is asserted.
SENSE2	9	Monitor voltage input to SVS-2	When the voltage at this terminal drops below the threshold voltage (V_{ITN}), RESET2 is asserted.
SENSE3	8	Monitor voltage input to SVS-3	When the voltage at this terminal drops below the threshold voltage (V_{ITN}), RESET3 is asserted.
SENSE4L	7	Falling monitor voltage input to SVS-4. When the voltage at this terminal drops below the threshold voltage (V_{ITN}), RESET4 or RESET4 is asserted.	
SENSE4H	6	Rising monitor voltage input to SVS-4. When the voltage at this terminal exceeds the threshold voltage (V_{ITP}), RESET4 or RESET4 is asserted. This pin can also be used to monitor the negative voltage rail in combination with VREF pin. Connect to GND if not being used.	
CT1	5	Reset delay programming pin for SVS-1	Connecting this pin to VCC through a 40kΩ to 200kΩ resistor, or leaving it open, selects a fixed delay time (see the Electrical Characteristics). Connecting a capacitor > 220pF between this pin and GND selects the programmable delay time (see the Reset Delay Time section).
CT2	4	Reset delay programming pin for SVS-2	
CT3	3	Reset delay programming pin for SVS-3	
CT4	2	Reset delay programming pin for SVS-4	
VREF	13	Reference voltage output. By connecting a resistor network between this pin and the negative power rail, SENSE4H can monitor the negative power rail. This pin is intended to only source current into resistor(s). Do not connect resistor(s) to a voltage higher than 1.2V. Do not connect only a capacitor.	
\overline{MR}	1	Manual reset input for SVS-1. Logic low level of this pin asserts RESET1 or RESET1.	
WDI	20	Watchdog timer (WDT) trigger input. Inputting either a positive or negative logic edge every 610ms (typ) prevents WDT time out at the WDO or WDO pin. Timer starts from releasing event of RESET1 or RESET1.	
NC	11	Not connected. It is recommended to connect this pin to the GND pin (pin 12), which is next to this pin.	
(Thermal Pad)	(PAD)	This is the IC substrate. This pad must be connected only to GND or to the floating thermal pattern on the printed circuit board (PCB).	

PIN ASSIGNMENTS (continued)

PIN		DESCRIPTION
NAME	NO.	
TPS386000		
$\overline{\text{RESET}}1$	15	Active low reset output of SVS-1
$\overline{\text{RESET}}2$	16	Active low reset output of SVS-2
$\overline{\text{RESET}}3$	17	Active low reset output of SVS-3
$\overline{\text{RESET}}4$	18	Active low reset output of SVS-4
$\overline{\text{WDO}}$	19	Watchdog timer output. This is an open-drain output pin. When WDT times out, this pin goes to a low-impedance state to GND. If there is no WDT timeout, this pin stays in a high-impedance state.
TPS386020		
RESET1	15	Active high reset output of SVS-1
RESET2	16	Active high reset output of SVS-2
RESET3	17	Active high reset output of SVS-3
RESET4	18	Active high reset output of SVS-4
WDO	19	Watchdog timer output. This is an open-drain output pin. When WDT times out, this pin goes to a high-impedance state. If there is no WDT timeout, this pin stays in a low-impedance state to GND.
TPS386040		
$\overline{\text{RESET}}1$	15	Active low reset output of SVS-1
$\overline{\text{RESET}}2$	16	Active low reset output of SVS-2
$\overline{\text{RESET}}3$	17	Active low reset output of SVS-3
$\overline{\text{RESET}}4$	18	Active low reset output of SVS-4
$\overline{\text{WDO}}$	19	Watchdog timer output. This is a push-pull output pin. When WDT times out, this pin goes to logic low. If there is no WDT timeout, this pin stays in logic high.
TPS386060		
RESET1	15	Active high reset output of SVS-1
RESET2	16	Active high reset output of SVS-2
RESET3	17	Active high reset output of SVS-3
RESET4	18	Active high reset output of SVS-4
WDO	19	Watchdog timer output. This is a push-pull output pin. When WDT times out, this pin goes to logic high. If there is no WDT timeout, this pin stays in logic low.

FUNCTIONAL BLOCK DIAGRAMS

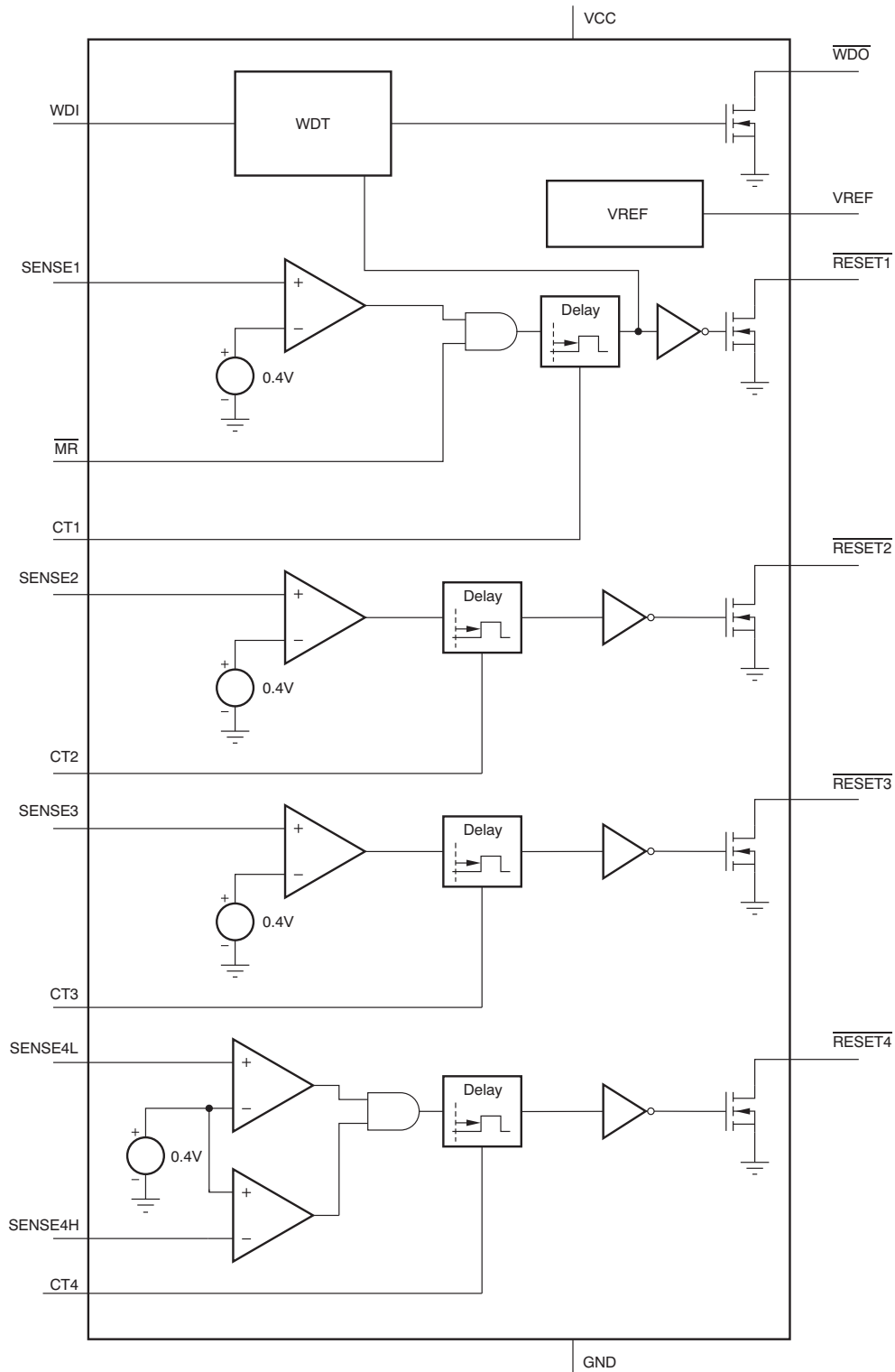

Figure 1. TPS386000 Block Diagram

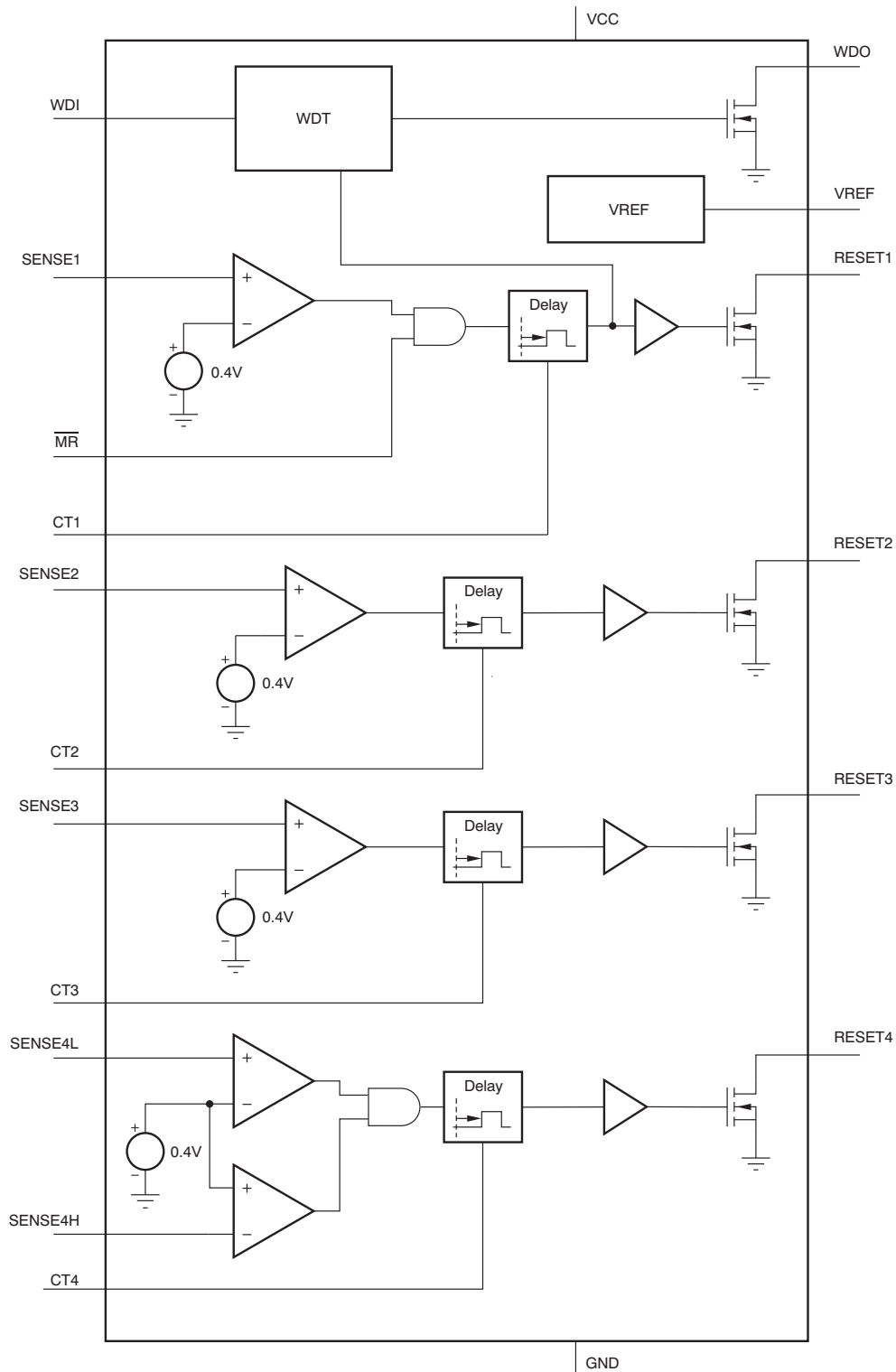

Figure 2. TPS386020 Block Diagram

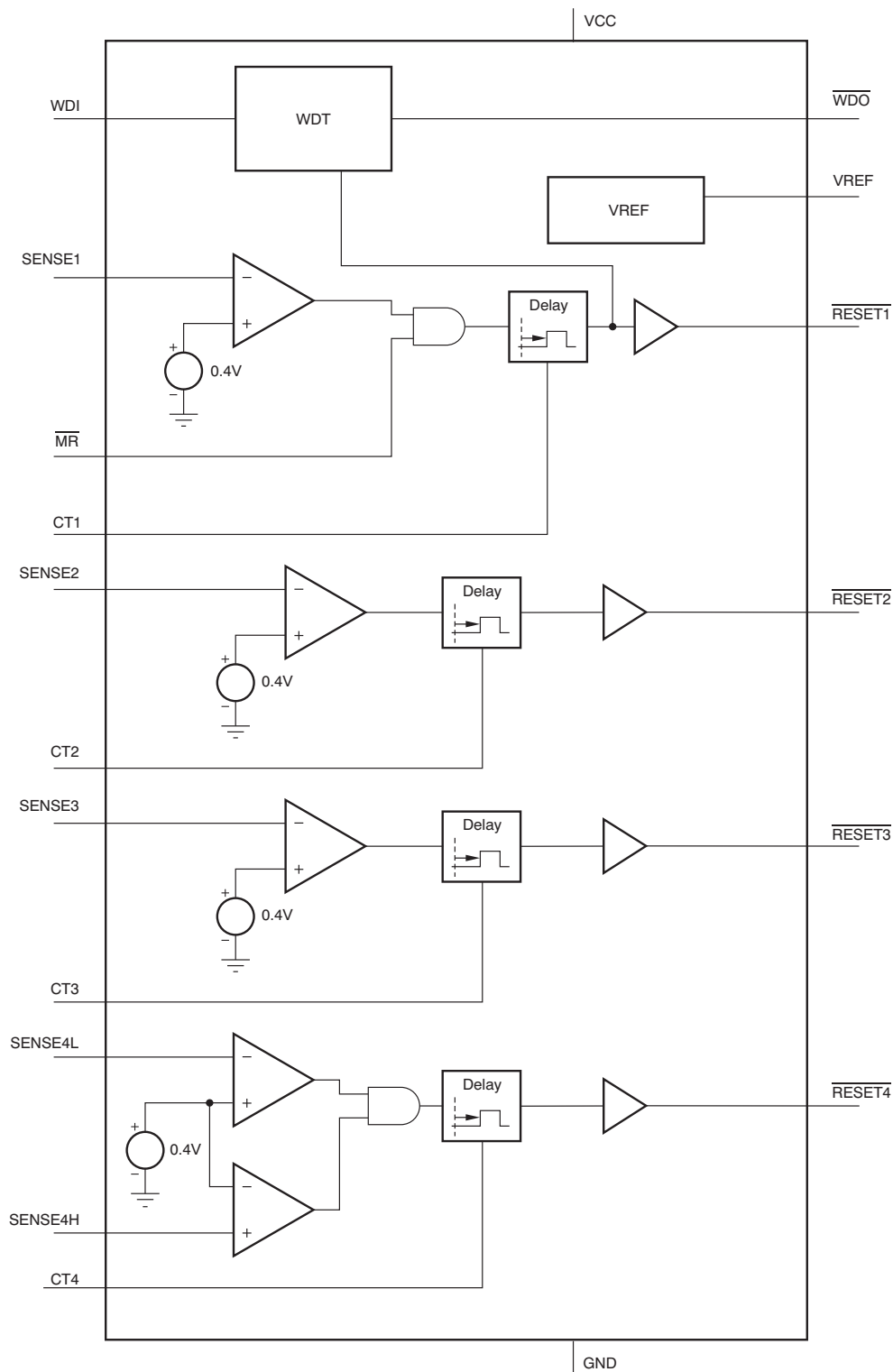

Figure 3. TPS386040 Block Diagram

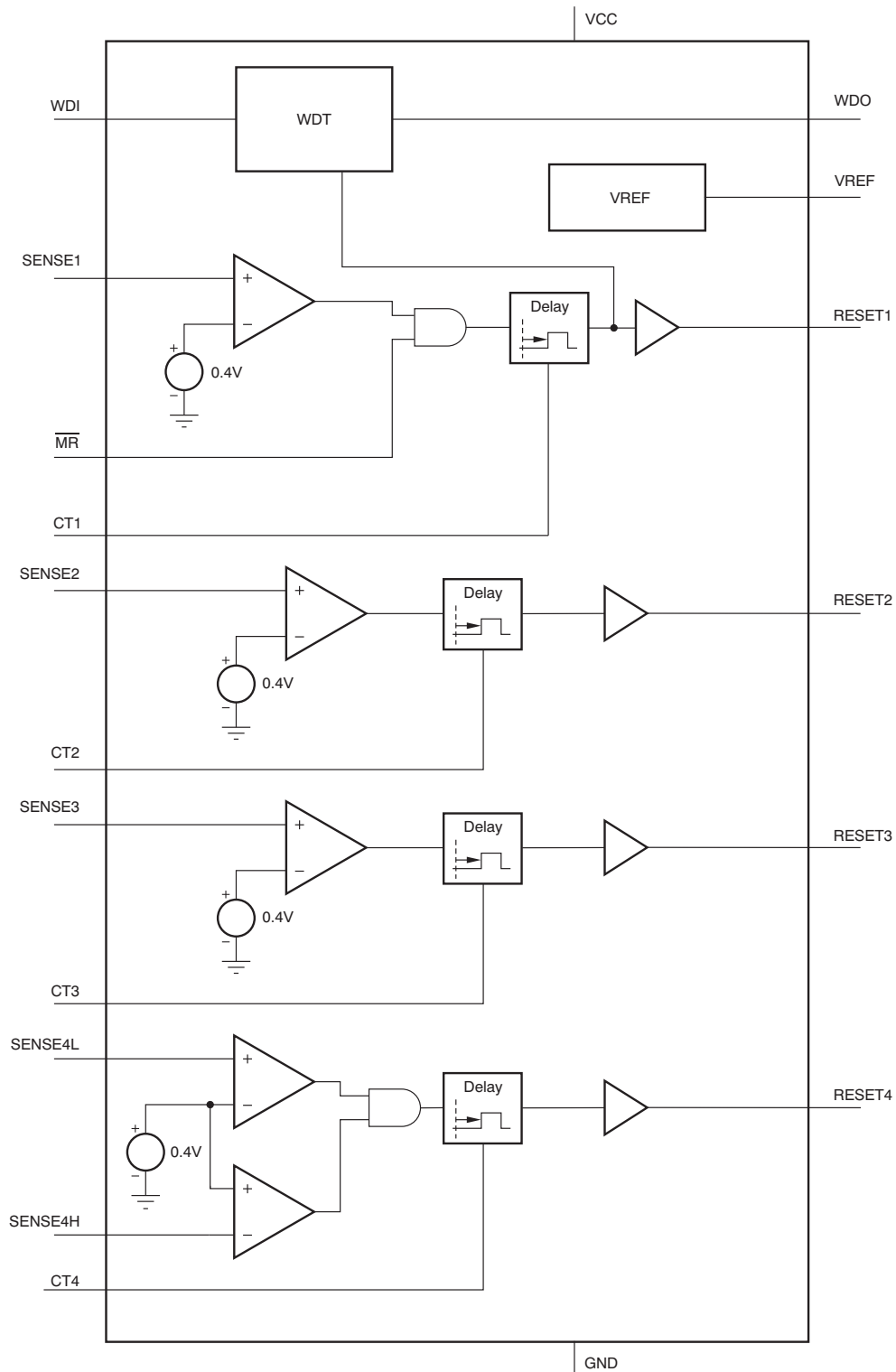

Figure 4. TPS386060 Block Diagram

TYPICAL CHARACTERISTICS

At $T_A = +25^\circ\text{C}$, and $V_{CC} = 3.3\text{V}$, with all four options (TPS386000, TPS386020, TPS386040, and TPS386060) having the same characteristics, unless otherwise noted.

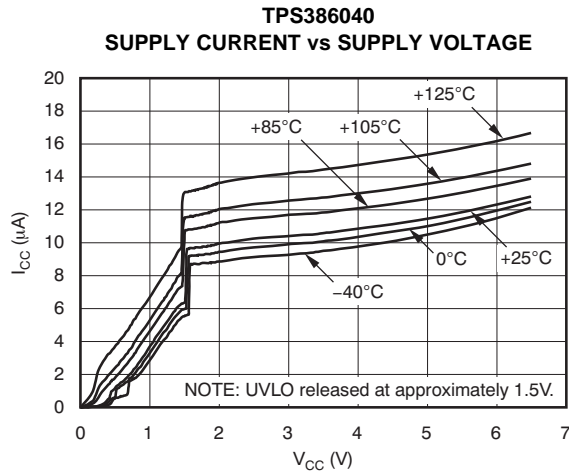

Figure 5.

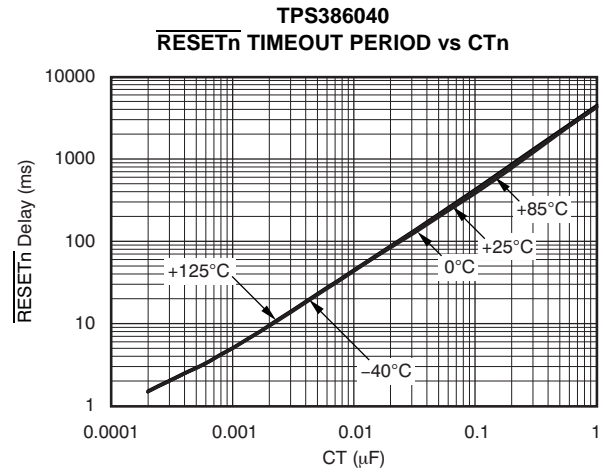

Figure 6.

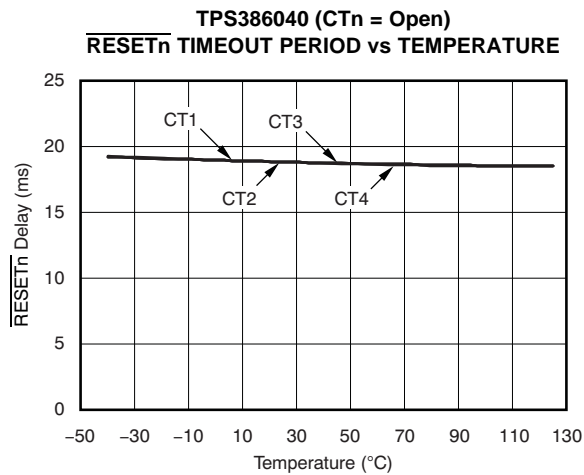

Figure 7.

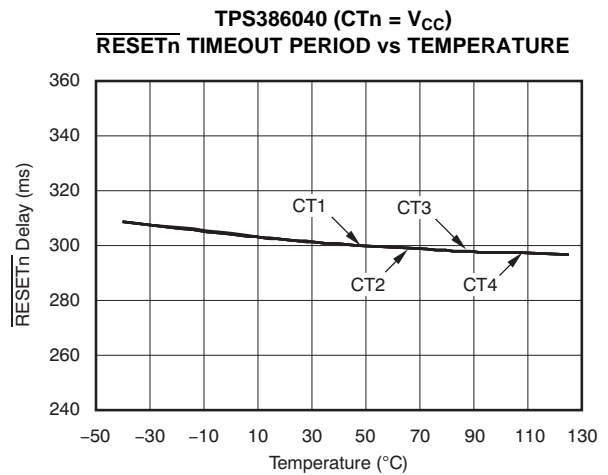

Figure 8.

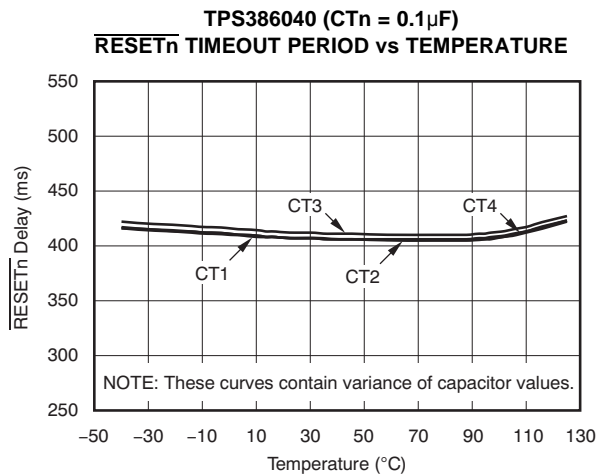

Figure 9.

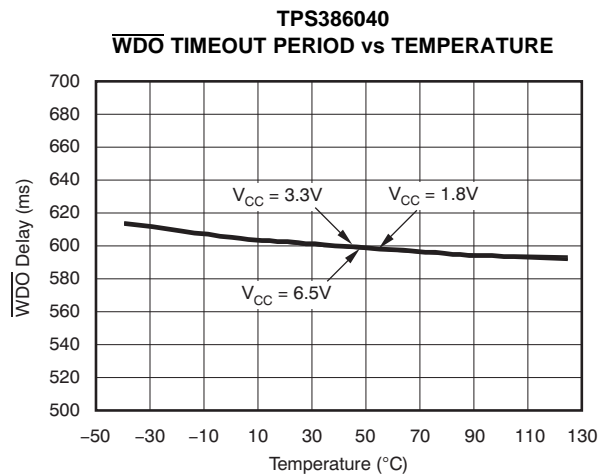

Figure 10.

TYPICAL CHARACTERISTICS (continued)

At $T_A = +25^\circ\text{C}$, and $V_{CC} = 3.3\text{V}$, with all four options (TPS386000, TPS386020, TPS386040, and TPS386060) having the same characteristics, unless otherwise noted.

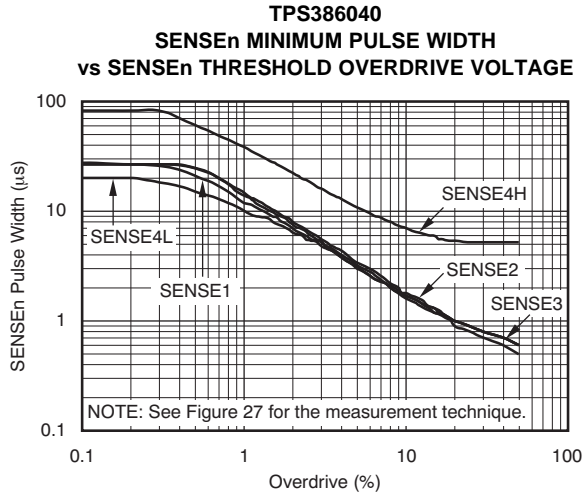

Figure 11.

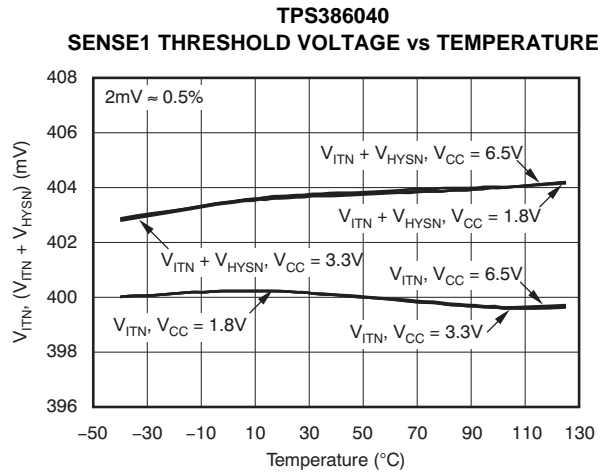

Figure 12.

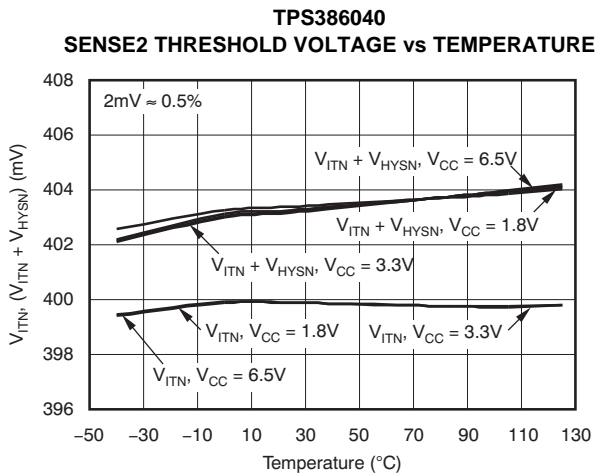

Figure 13.

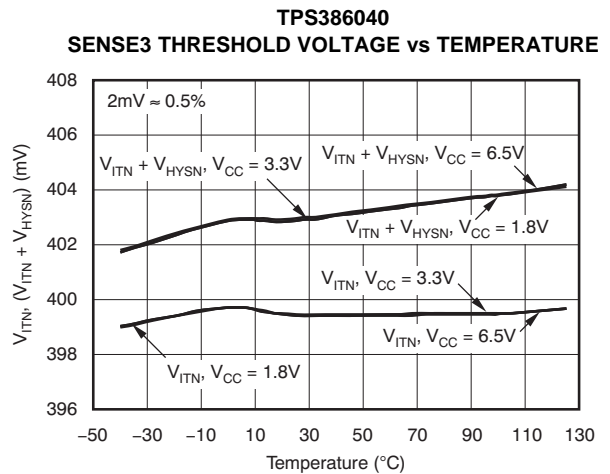

Figure 14.

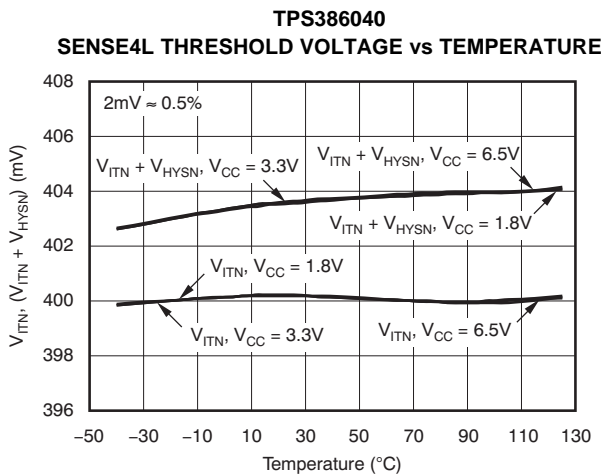

Figure 15.

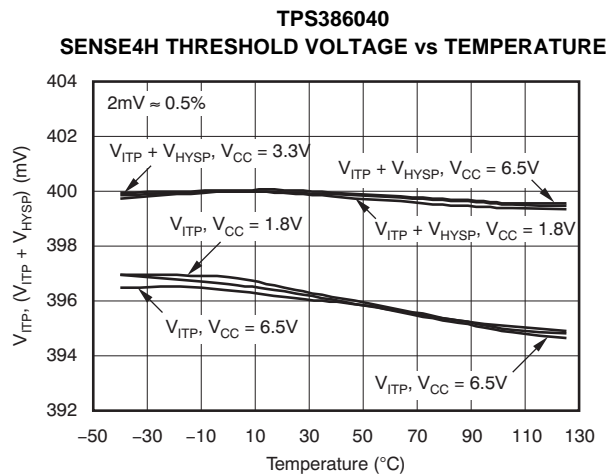

Figure 16.

TYPICAL CHARACTERISTICS (continued)

At $T_A = +25^\circ\text{C}$, and $V_{CC} = 3.3\text{V}$, with all four options (TPS386000, TPS386020, TPS386040, and TPS386060) having the same characteristics, unless otherwise noted.

OUTPUT VOLTAGE LOW vs OUTPUT CURRENT

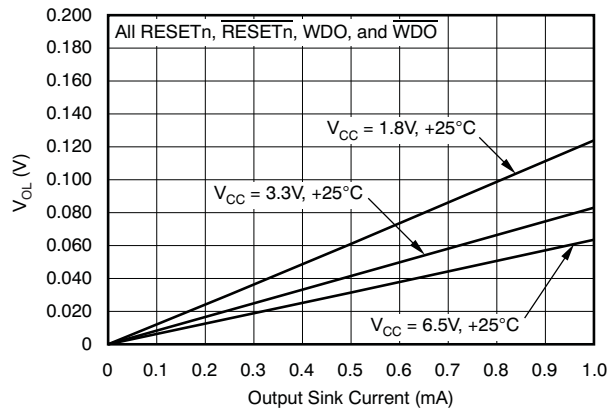

Figure 17.

OUTPUT VOLTAGE LOW AT 1mA vs TEMPERATURE

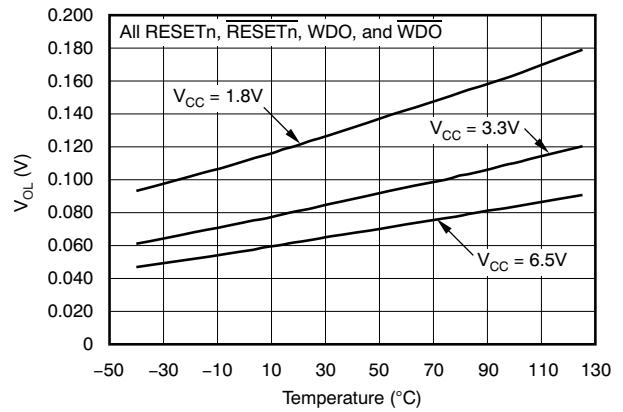

Figure 18.

OUTPUT VOLTAGE HIGH vs OUTPUT CURRENT

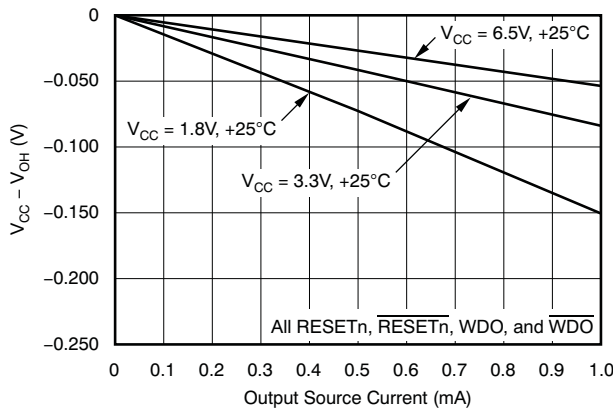

Figure 19.

OUTPUT VOLTAGE HIGH AT 1mA vs TEMPERATURE

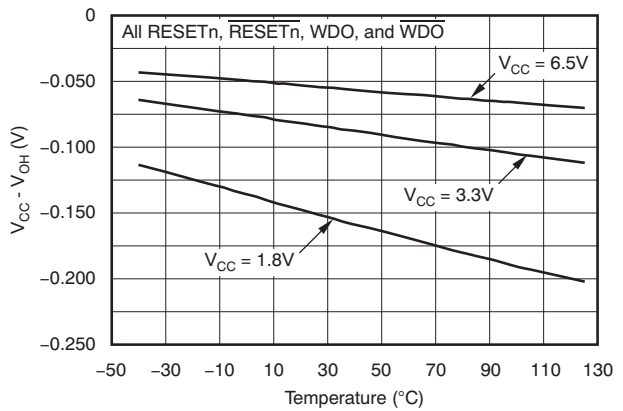

Figure 20.

TPS386040

V_REF OUTPUT LOAD REGULATION ($V_{CC} = 1.8\text{V}$)

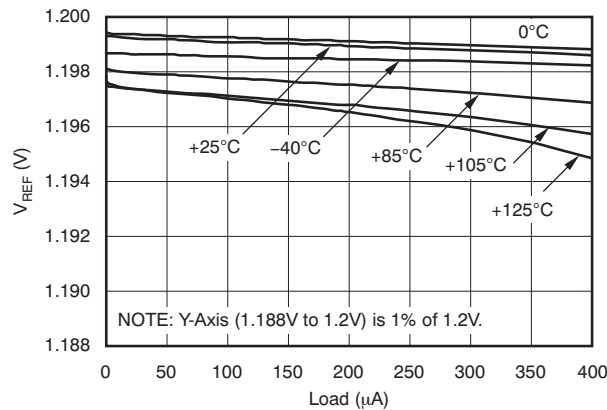

Figure 21.

TPS386040

V_REF OUTPUT LOAD REGULATION ($V_{CC} = 3.3\text{V}$)

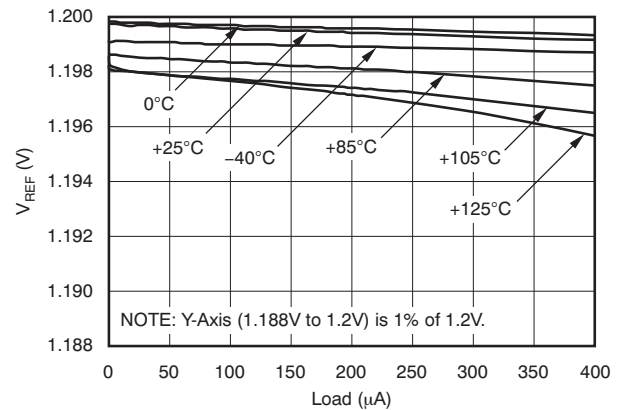

Figure 22.

TYPICAL CHARACTERISTICS (continued)

At $T_A = +25^\circ\text{C}$, and $V_{CC} = 3.3\text{V}$, with all four options (TPS386000, TPS386020, TPS386040, and TPS386060) having the same characteristics, unless otherwise noted.

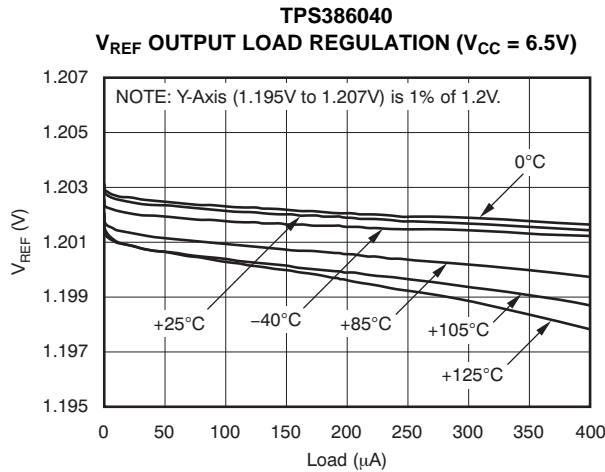

Figure 23.

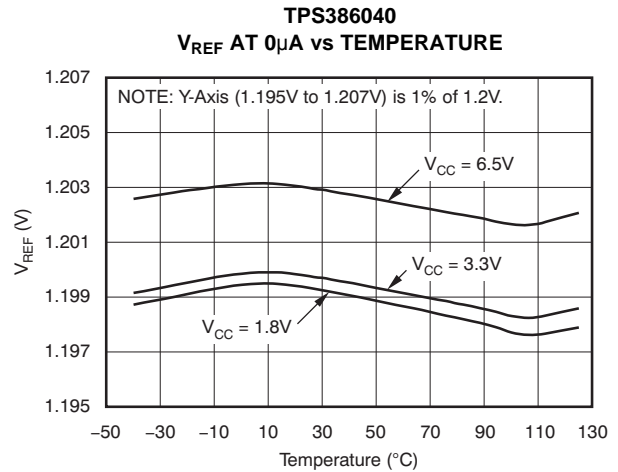

Figure 24.

TPS386040 CT1 TO CT4 PIN CHARGING CURRENT vs TEMPERATURE OVER CT PIN VOLTAGE

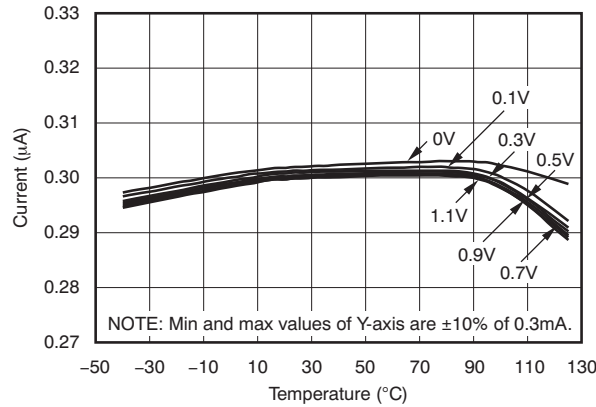
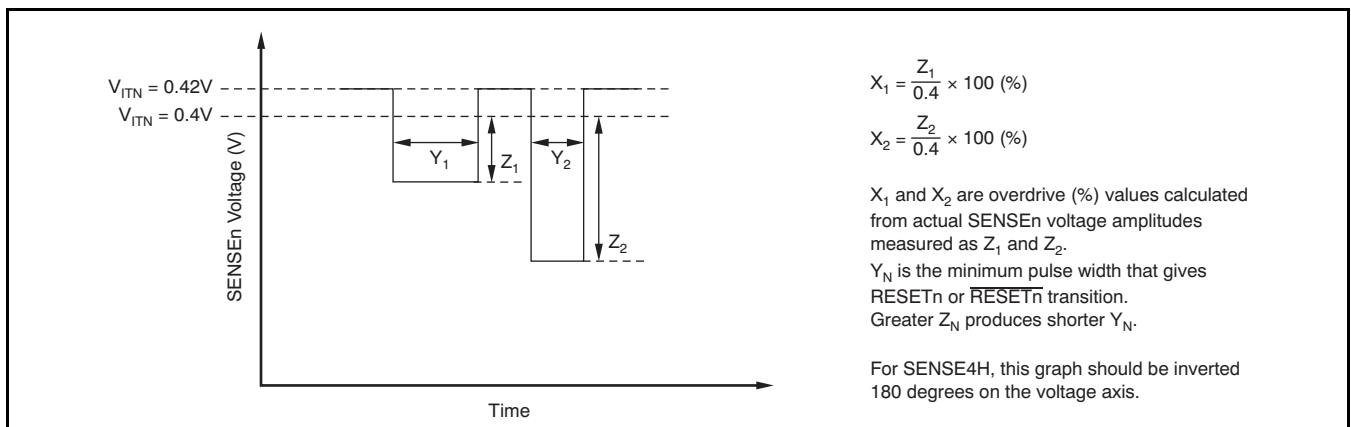

Figure 25.

PARAMETRIC MEASUREMENT INFORMATION

TEST CIRCUIT



GENERAL DESCRIPTION

The TPS3860x0 multi-channel supervisory device family combines four complete SVS function sets into one IC, along with a watchdog timer, a window comparator, and negative voltage sensing. The design of each SVS channel is based on the single-channel supervisory device series, [TPS3808](#). The TPS3860x0 is designed to assert $\overline{\text{RESET}}_n$ or RESET_n signals, as shown in [Table 1](#), [Table 2](#), [Table 3](#), and [Table 4](#). The $\overline{\text{RESET}}_n$ or RESET_n outputs remain asserted during a

user-configurable delay time after the event of reset release (see the [Reset Delay Time](#) section). Each SENSE_m ($m = 1, 2, 3, 4L$) pin can be set to any voltage threshold above 0.4V using an external resistor divider. The SENSE4H pin can be used for any overvoltage detection greater than 0.4V, or for negative voltage detection using an external resistor divider (see the [Sensing Voltage Less Than 0.4V](#) section). A broad range of voltage threshold and reset delay time adjustments can be supported, allowing these devices to be used in a wide array of applications.

Table 1. SVS-1 Truth Table

CONDITION		OUTPUT		STATUS
		TPS386000 TPS386040	TPS386020 TPS386060	
$\overline{\text{MR}} = \text{Low}$	$\text{SENSE1} < V_{\text{ITN}}$	$\overline{\text{RESET}}_1 = \text{Low}$	$\text{RESET}_1 = \text{High}$	Reset asserted
$\overline{\text{MR}} = \text{Low}$	$\text{SENSE1} > V_{\text{ITN}}$	$\overline{\text{RESET}}_1 = \text{Low}$	$\text{RESET}_1 = \text{High}$	Reset asserted
$\overline{\text{MR}} = \text{High}$	$\text{SENSE1} < V_{\text{ITN}}$	$\overline{\text{RESET}}_1 = \text{Low}$	$\text{RESET}_1 = \text{High}$	Reset asserted
$\overline{\text{MR}} = \text{High}$	$\text{SENSE1} > V_{\text{ITN}}$	$\overline{\text{RESET}}_1 = \text{High}$	$\text{RESET}_1 = \text{Low}$	Reset released after delay

Table 2. SVS-2 Truth Table

CONDITION	OUTPUT		STATUS
	TPS386000 TPS386040	TPS386020 TPS386060	
$\text{SENSE2} < V_{\text{ITN}}$	$\overline{\text{RESET}}_2 = \text{Low}$	$\text{RESET}_2 = \text{High}$	Reset asserted
$\text{SENSE2} > V_{\text{ITN}}$	$\overline{\text{RESET}}_2 = \text{High}$	$\text{RESET}_2 = \text{Low}$	Reset released after delay

Table 3. SVS-3 Truth Table

CONDITION		OUTPUT		STATUS
		TPS386000 TPS386040	TPS386020 TPS386060	
$\text{SENSE3} < V_{\text{ITN}}$		$\overline{\text{RESET}}_3 = \text{Low}$	$\text{RESET}_3 = \text{High}$	Reset asserted
$\text{SENSE3} > V_{\text{ITN}}$		$\overline{\text{RESET}}_3 = \text{High}$	$\text{RESET}_3 = \text{Low}$	Reset released after delay

Table 4. SVS-4 Truth Table

CONDITION		OUTPUT		STATUS
		TPS386000 TPS386040	TPS386020 TPS386060	
$\text{SENSE4L} < V_{\text{ITN}}$	$\text{SENSE4H} > V_{\text{ITP}}$	$\overline{\text{RESET}}_4 = \text{Low}$	$\text{RESET}_4 = \text{High}$	Reset asserted
$\text{SENSE4L} < V_{\text{ITN}}$	$\text{SENSE4H} < V_{\text{ITP}}$	$\overline{\text{RESET}}_4 = \text{Low}$	$\text{RESET}_4 = \text{High}$	Reset asserted
$\text{SENSE4L} > V_{\text{ITN}}$	$\text{SENSE4H} > V_{\text{ITP}}$	$\overline{\text{RESET}}_4 = \text{Low}$	$\text{RESET}_4 = \text{High}$	Reset asserted
$\text{SENSE4L} > V_{\text{ITN}}$	$\text{SENSE4H} < V_{\text{ITP}}$	$\overline{\text{RESET}}_4 = \text{High}$	$\text{RESET}_4 = \text{Low}$	Reset released after delay

Table 5. Watchdog Timer (WDT) Truth Table

CONDITION				OUTPUT		STATUS
$\overline{\text{WDO}}$	WDO	$\overline{\text{RESET1}}$ OR RESET1	WDI PULSE INPUT	TPS386000 TPS386040	TPS386020 TPS386060	
Low	High	Asserted	Toggling	$\overline{\text{WDO}} = \text{low}$	WDO = high	Remains in WDT timeout
Low	High	Asserted	610ms after last WDI \uparrow or WDI \downarrow	$\overline{\text{WDO}} = \text{low}$	WDO = high	Remains in WDT timeout
Low	High	Released	Toggling	$\overline{\text{WDO}} = \text{low}$	WDO = high	Remains in WDT timeout
Low	High	Released	610ms after last WDI \uparrow or WDI \downarrow	$\overline{\text{WDO}} = \text{low}$	WDO = high	Remains in WDT timeout
High	Low	Asserted	Toggling	$\overline{\text{WDO}} = \text{high}$	WDO = low	Normal operation
High	Low	Asserted	610ms after last WDI \uparrow or WDI \downarrow	$\overline{\text{WDO}} = \text{high}$	WDO = low	Normal operation
High	Low	Released	Toggling	$\overline{\text{WDO}} = \text{high}$	WDO = low	Normal operation
High	Low	Released	610ms after last WDI \uparrow or WDI \downarrow	$\overline{\text{WDO}} = \text{low}$	WDO = high	Enters WDT timeout

RESET OUTPUT

In a typical TPS3860x0 application, $\overline{\text{RESETn}}$ or RESETn outputs are connected to the reset input of a processor (DSP, CPU, FPGA, ASIC, etc.), or connected to the enable input of a voltage regulator (DC-DC, LDO, etc.)

The TPS386000 and TPS386020 provide open-drain reset outputs. Pull-up resistors must be used to hold these lines high when $\overline{\text{RESETn}}$ is not asserted, or when RESETn is asserted. By connecting pull-up resistors to the proper voltage rails (up to 6.5V), $\overline{\text{RESETn}}$ or RESETn output nodes can be connected to the other devices at the correct interface voltage levels. The pull-up resistor should be no smaller than 10k Ω because of the safe operation of the output transistors. By using wired-OR logic, any combination of $\overline{\text{RESETn}}$ can be merged into one logic signal.

The TPS386040 and TPS386060 provide push-pull reset outputs. The logic high level of the outputs is determined by the VCC voltage. With this configuration, pull-up resistors are not required and some board area can be saved. However, all the interface logic levels should be examined. All $\overline{\text{RESETn}}$ or RESETn connections must be compatible with the VCC logic level.

The $\overline{\text{RESETn}}$ or RESETn outputs are defined for VCC voltage higher than 0.9V. To ensure that the target processor(s) are properly reset, the VCC supply input should be fed by the available power rail as early as possible in application circuits. Table 1, Table 2, Table 3, and Table 4 are truth tables that describe how the outputs are asserted or released. Figure 26, Figure 27, Figure 28, and Figure 29 show the SVS-n timing diagrams. When the condition(s) are met, the device changes the state of SVS-n from asserted to released after a user-configurable delay time. However, the transitions from released-state to asserted-state are performed almost immediately with minimal propagation delay. Figure 28 describes relationship between threshold voltages (V_{ITN} and V_{HYSN}) and SENSEm voltage; and all SVS-1, SVS-2, SVS-3, and SVS-4 have the same behavior of Figure 28.

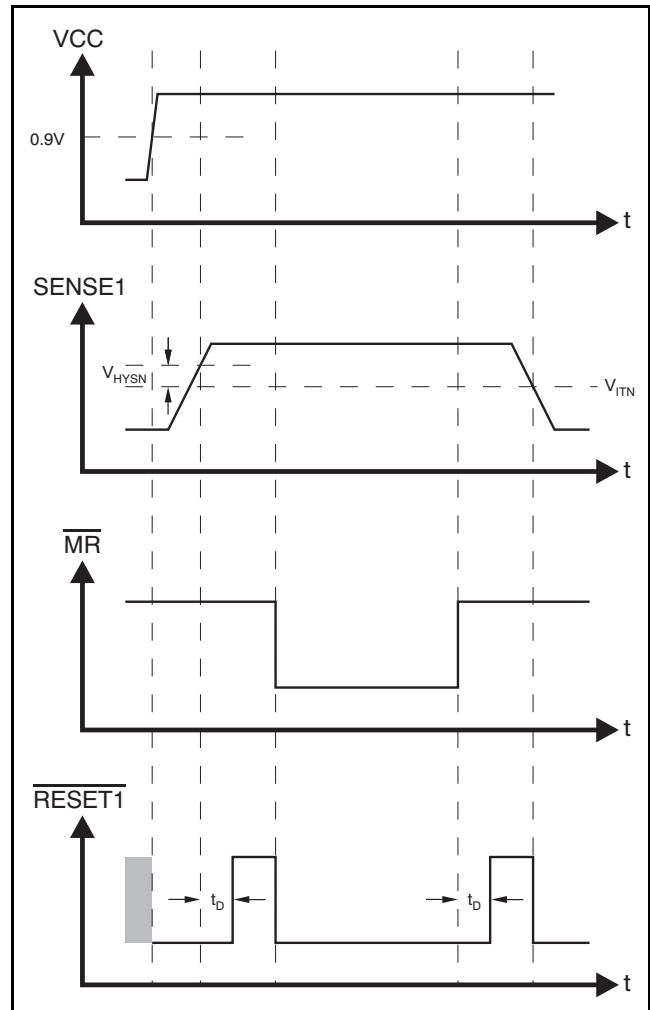

NOTE: The TPS386000 or TPS386040 is shown here using $\overline{\text{RESETn}}$. The TPS386020 and TPS386060 use RESETn; therefore, the diagram of $\overline{\text{RESETn}}$ should be read as RESETn with the opposite polarity.

Figure 26. SVS-1 Timing Diagram

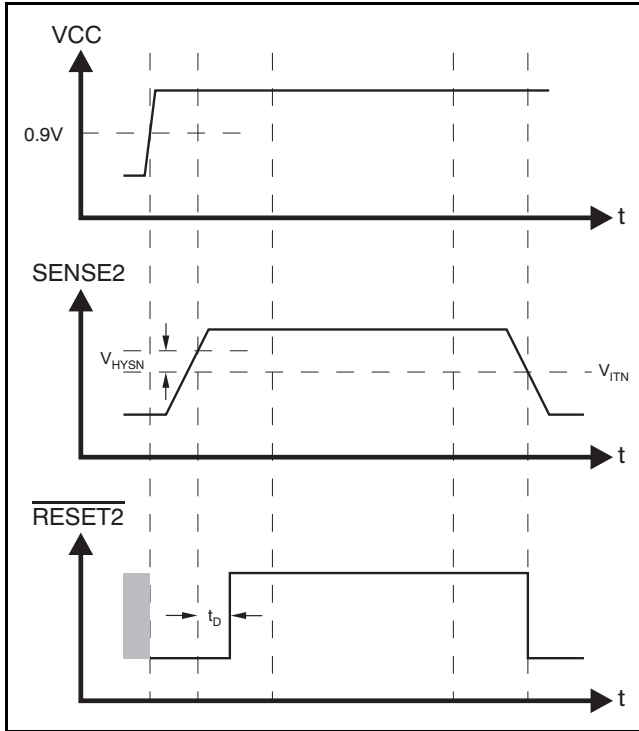

NOTE: The TPS386000 or TPS386040 is shown here using $\overline{\text{RESETn}}$. The TPS386020 and TPS386060 use RESETn ; therefore, the diagram of $\overline{\text{RESETn}}$ should be read as RESETn with the opposite polarity.

Figure 27. SVS-2 Timing Diagram

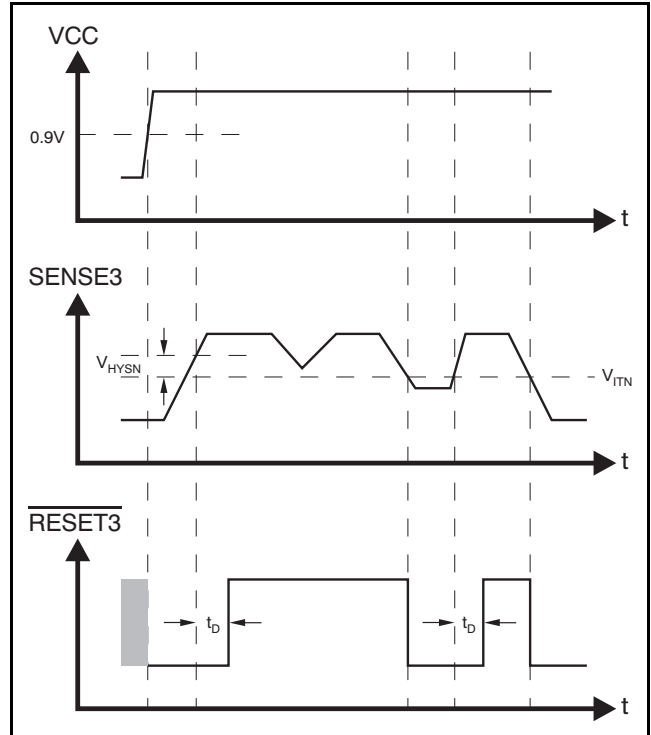

NOTE: The TPS386000 or TPS386040 is shown here using $\overline{\text{RESETn}}$. The TPS386020 and TPS386060 use RESETn ; therefore, the diagram of $\overline{\text{RESETn}}$ should be read as RESETn with the opposite polarity.

Figure 28. SVS-3 Timing Diagram

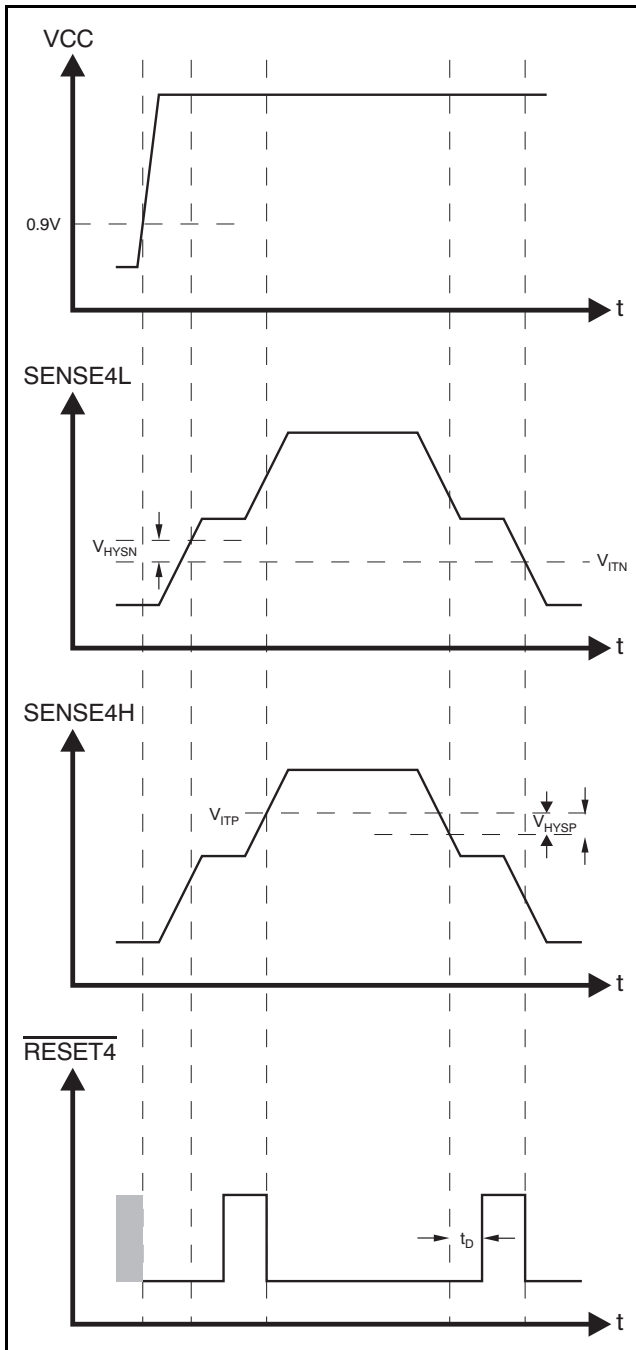

NOTE: The TPS386000 or TPS386040 is shown here using $\overline{\text{RESETn}}$. The TPS386020 and TPS386060 use RESETn ; therefore, the diagram of $\overline{\text{RESETn}}$ should be read as RESETn with the opposite polarity.

Figure 29. SVS-4 Timing Diagram

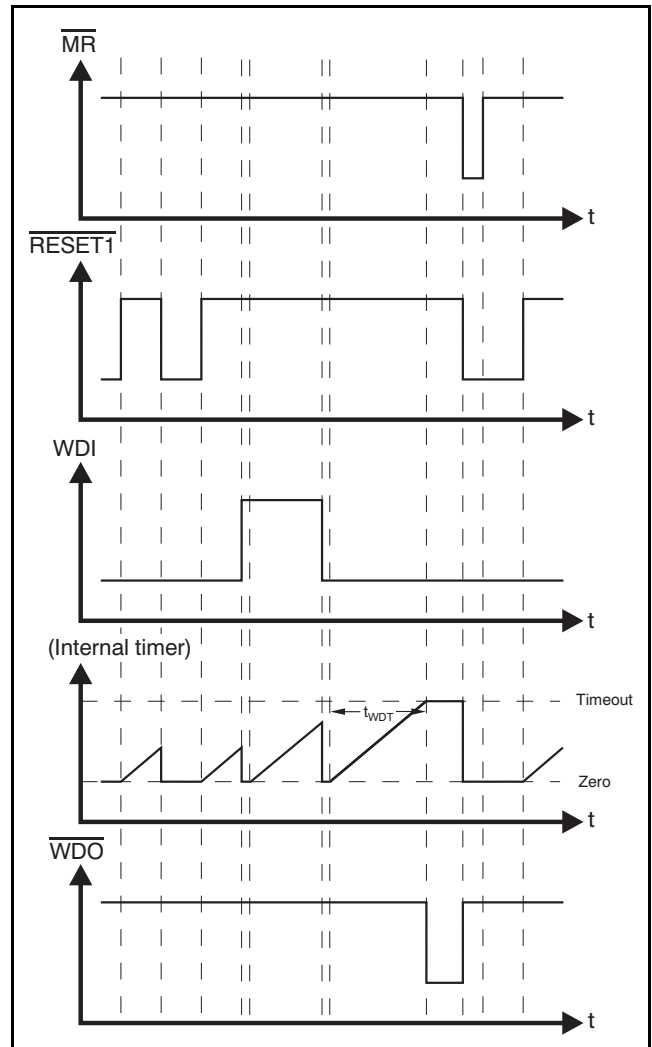

NOTE: The TPS386000 or TPS386040 is shown here using $\overline{\text{RESETn}}$ and $\overline{\text{WDO}}$. The TPS386020 and TPS386060 use RESETn and WDO ; therefore, the diagrams of $\overline{\text{RESETn}}$ and $\overline{\text{WDO}}$ should be read as RESETn and WDO with the opposite polarities.

Figure 30. WDT Timing Diagram

SENSE INPUT

The SENSEm inputs are pins that allow any system voltages to be monitored. If the voltage at the SENSE1, SENSE2, SENSE3, or SENSE4L pins drops below V_{ITN} , then the corresponding reset outputs are asserted. If the voltage at the SENSE4H pin exceeds V_{ITP} , then $\overline{\text{RESET4}}$ or RESET4 is asserted. The comparators have a built-in hysteresis to ensure smooth reset output assertions and deassertions. Although not required in most cases, for extremely noise applications, it is good analog

design practice to place a 1nF to 10nF bypass capacitor at the SENSEm input in order to reduce sensitivity to transients, layout parasitics, and interference between power rails monitored by this device. A typical connection of resistor dividers are shown in Figure 31. All the SENSEm pins can be used to monitor voltage rails down to 0.4V. Threshold voltages can be calculated by following equations:

$$\text{VCC1_target} = (1 + R_{S1H}/R_{S1L}) \times 0.4 \text{ (V)} \quad (1)$$

$$\text{VCC2_target} = (1 + R_{S2H}/R_{S2L}) \times 0.4 \text{ (V)} \quad (2)$$

$$\text{VCC3_target} = (1 + R_{S3H}/R_{S3L}) \times 0.4 \text{ (V)} \quad (3)$$

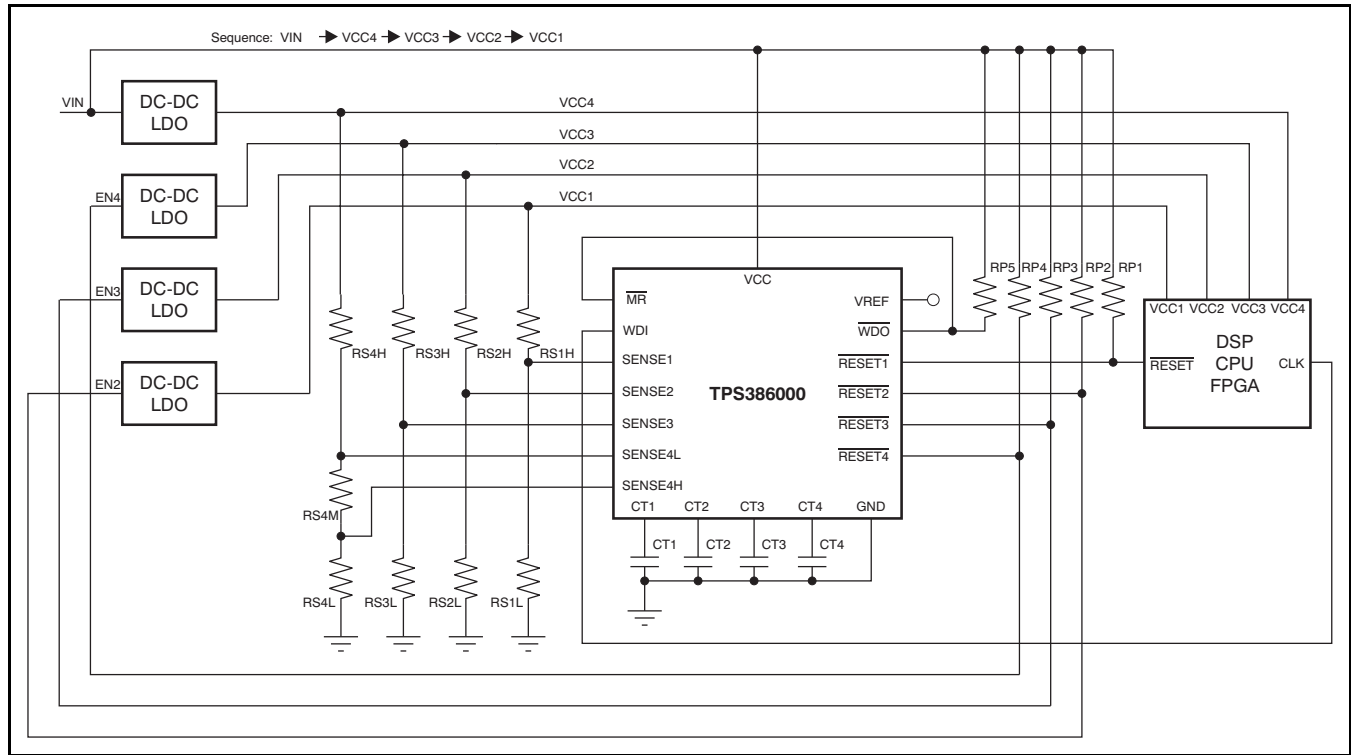

Figure 31. Typical Application Circuit

WINDOW COMPARATOR

The comparator at the SENSE4H pin has the opposite comparison polarity to the other SENSEm pins. In the configuration shown in Figure 32, this comparator monitors overvoltage of the VCC4 node; combined with the comparator at SENSE4L, SVS-4 forms a window comparator.

$$VCC4_target1 = \{1 + R_{S4H}/(R_{S4M} + R_{S4L})\} \times 0.4 \text{ (V)} \quad (4)$$

$$VCC4_target2 = \{1 + (R_{S4H} + R_{S4M})/R_{S4L}\} \times 0.4 \text{ (V)} \quad (5)$$

Where VCC4_target1 is the undervoltage threshold, and VCC4_target2 is the overvoltage threshold.

SENSING VOLTAGE LESS THAN 0.4V

By using voltage reference output VREF, the SVS-4 comparator can monitor negative voltage or positive voltage lower than 0.4V. Figure 33 shows this usage in an application circuit. SVS-4 monitors the positive and negative voltage power rail (for example, +15V and -15V supply to an op amp) and the RESET4 or RESET4 output status continues to be as described in Table 4. Note that R_{S42H} is located at higher voltage position than R_{S42L}. The threshold voltage calculations are shown in the following equations:

$$VCC41_target = (1 + R_{S41H}/R_{S41L}) \times 0.4 \text{ (V)} \quad (6)$$

$$VCC42_target = (1 + R_{S42L}/R_{S42H}) \times 0.4 - R_{S42L}/R_{S42H} \times V_{REF} \quad (7)$$

$$= 0.4 - (R_{S42L}/R_{S42H} \times 0.8 \text{ (V)}) \quad (8)$$

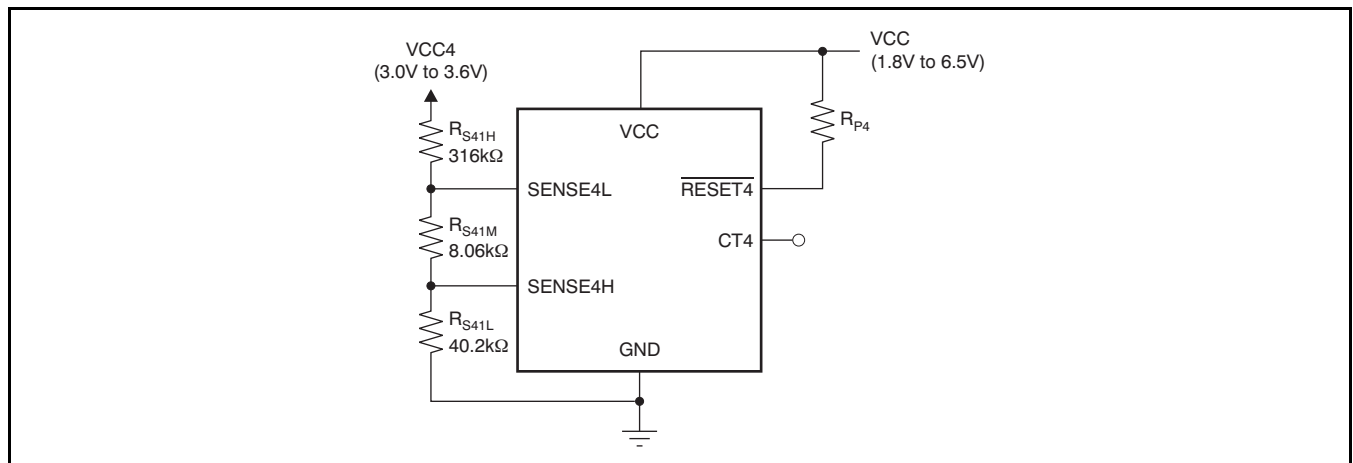

Figure 32. SVS-4: Window Comparator

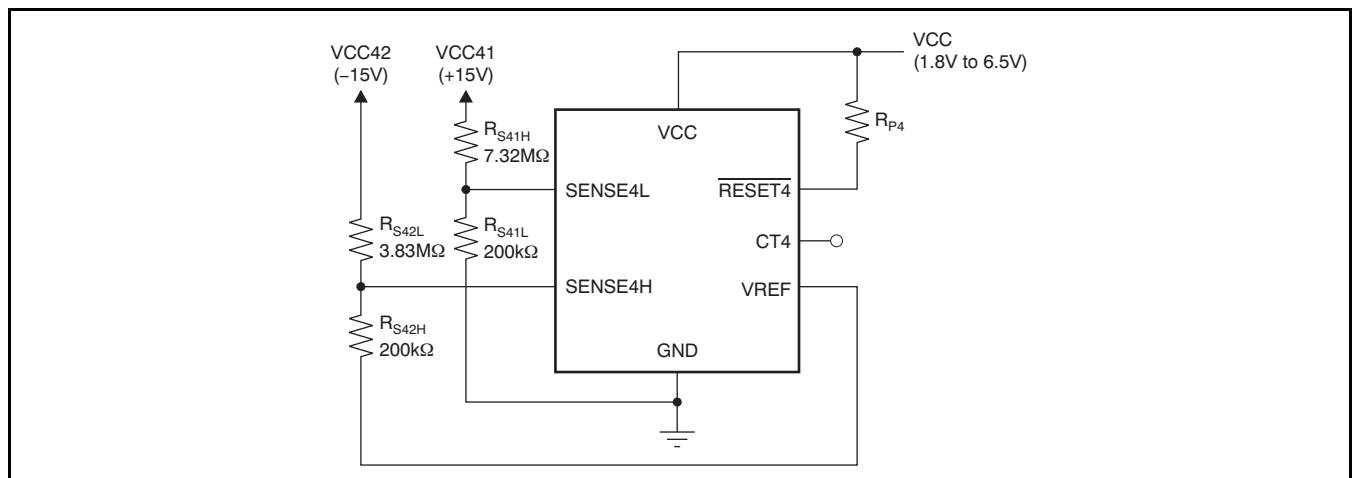

Figure 33. SVS4: Negative Voltage Sensing

RESET DELAY TIME

Each of the SVS-n channels can be configured independently in one of three modes. [Table 6](#) describes the delay time settings.

Table 6. Delay Timing Selection

CTn CONNECTION	DELAY TIME
Pull-up to VCC	300ms (typ)
Open	20 ms (typ)
Capacitor to GND	Programmable

To select the 300ms fixed delay time, the CTn pin should be pulled up to VCC using a resistor from 40kΩ to 200kΩ. Please note that there is a pulldown transistor from CTn to GND that turns on every time the device powers on to determine and confirm CTn pin status; therefore, a direct connection of CTn to VCC causes a large current flow. To select the 20ms fixed delay time, the CTn pin should be left open. To program a user-defined adjustable delay time, an external capacitor must be connected between CTn and GND. The adjustable delay time can be calculated by the following equation:

$$C_{CT} \text{ (nF)} = [t_{\text{DELAY}} \text{ (ms)} - 0.5 \text{ (ms)}] \times 0.242 \quad (9)$$

Using this equation, a delay time can be set to between 1.4ms to 10s. The external capacitor should be greater than 220pF (nominal) so that the TPS3860x0 can distinguish it from an open CT pin. The reset delay time is determined by the time it takes an on-chip, precision 300nA current source to charge the external capacitor to 1.24V. When the $\overline{\text{RESET}}_n$ or RESET_n outputs are asserted, the corresponding capacitors are discharged. When the condition to release $\overline{\text{RESET}}_n$ or RESET_n occurs, the internal current sources are enabled and begin to charge the external capacitors. When the CTn voltage on a capacitor reaches 1.24V, the corresponding $\overline{\text{RESET}}_n$ or RESET_n pins are released. Note that a low leakage type capacitor (such as ceramic) should be used, and that stray capacitance around this pin may cause errors in the reset delay time.

MANUAL RESET

The manual reset ($\overline{\text{MR}}$) input allows external logic signal from other processors, logic circuits, and/or discrete sensors to initiate a device reset. Because $\overline{\text{MR}}$ is connected to SVS-1, the $\overline{\text{RESET}}_1$ or RESET_1 pin is intended to be connected to processor(s) as a primary reset source. A logic low at $\overline{\text{MR}}$ causes $\overline{\text{RESET}}_1$ or RESET_1 to assert. After $\overline{\text{MR}}$ returns to a

logic high and SENSE_1 is above its reset threshold, $\overline{\text{RESET}}_1$ or RESET_1 is released after the user-configured reset delay time. Note that unlike the [TPS3808](#) series, the TPS3860x0 does not integrate an internal pull-up resistor between $\overline{\text{MR}}$ and VCC.

To control the $\overline{\text{MR}}$ function from more than one logic signal, the logic signals can be combined by wired-OR into the $\overline{\text{MR}}$ pin using multiple NMOS transistors and one pull-up resistor.

WATCHDOG TIMER

The TPS3860x0 provides a watchdog timer with a dedicated watchdog error output, $\overline{\text{WDO}}$ or WDO. The $\overline{\text{WDO}}$ or WDO output enables application board designers to easily detect and resolve the hang-up status of a processor. As with $\overline{\text{MR}}$, the watchdog timer function of the device is also tied to SVS-1. [Figure 30](#) shows the timing diagram of the WDT function. Once $\overline{\text{RESET}}_1$ or RESET_1 is released, the internal watchdog timer starts its countdown. Inputting a logic level transition at WDI resets the internal timer count and the timer restarts the countdown. If the TPS3860x0 fails to receive any WDI rising or falling edge within the WDT period, the WDT times out and asserts $\overline{\text{WDO}}$ or WDO. After $\overline{\text{WDO}}$ or WDO is asserted, the device holds the status with the internal latch circuit. To clear this timeout status, a reset assertion of $\overline{\text{RESET}}_1$ or RESET_1 is required. That is, a negative pulse to $\overline{\text{MR}}$, a SENSE_1 voltage less than V_{ITN} , or a VCC power-down is required.

To reset the processor by WDT timeout, $\overline{\text{WDO}}$ can be combined with $\overline{\text{RESET}}_1$ by using the wired-OR with the TPS386000 option.

For legacy applications where the watchdog timer timeout causes $\overline{\text{RESET}}_1$ to assert, connect WDO to $\overline{\text{MR}}$; see [Figure 31](#) for the connections and see [Figure 34](#) and [Figure 35](#) for the timing diagram. This legacy support configuration is available with the TPS386000 and TPS386040.

IMMUNITY TO SENSEn VOLTAGE TRANSIENTS

The TPS3860x0 is relatively immune to short negative transients on the SENSE_n pin. Sensitivity to transients depends on threshold overdrive, as shown in the typical performance graph *TPS386040 SENSEn Minimum Pulse Width vs SENSEn Threshold Overdrive Voltage* ([Figure 11](#)).

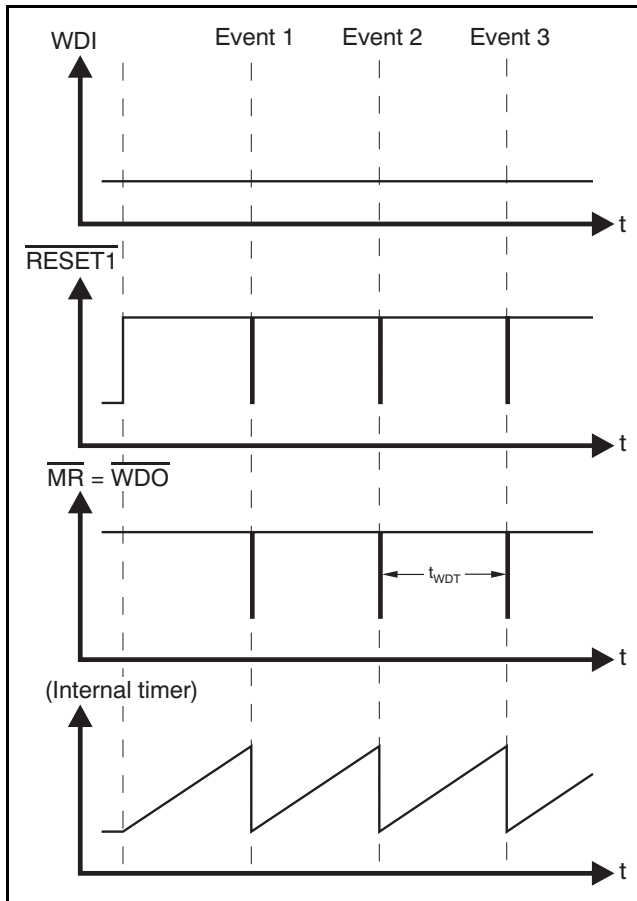

NOTE: This configuration (connecting \overline{WDO} and \overline{MR}) is available only with the TPS386000 and TPS386040.

Figure 34. Legacy WDT Configuration Timing Diagram

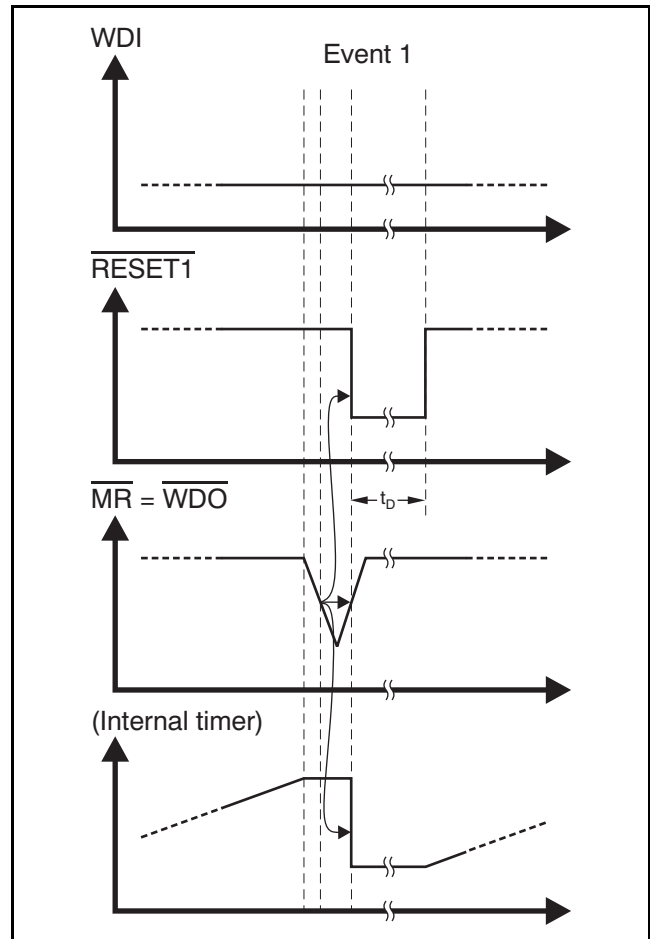

NOTE: This configuration (connecting \overline{WDO} and \overline{MR}) is available only with the TPS386000 and TPS386040.

Figure 35. Enlarged View of Event 1 from Figure 34

REVISION HISTORY

NOTE: Page numbers for previous revisions may differ from page numbers in the current version.

Changes from Revision A (January 2010) to Revision B	Page
• Changed data sheet title	1
• Changed Features bullets	1
• Changed Applications bullets	1
• Changed first sentence of second paragraph in Description text	1
• Changed low quiescent current value in last paragraph of Description text from 12 μ A to 11 μ A	1
• Changed front-page typical application circuit figure	1
• Added sentence to pin 6 description in Pin Assignments table	4
• Changed last sentence of pin 13 description in Pin Assignments table	4
• Added text to first sentence of first paragraph of <i>General Description</i> section.	14
• Changed caption for Figure 31	19
• Changed link in <i>Window Comparator</i> section to new Figure 32	20
• Deleted typo in Equation 4 and moved Equation 4 to <i>Window Comparator</i> section	20
• Deleted typo in Equation 5 and moved Equation 5 to <i>Window Comparator</i> section	20
• Changed link in <i>Sensing Voltage Less Than 0.4V</i> section to new Figure 33	20
• Added Figure 32	20
• Added Figure 33	20

Changes from Original (September 2009) to Revision A	Page
• Changed Features to update SVS bullets	1
• Changed first sentence of Description text.	1
• Changed text in <i>General Description</i> section regarding SENSE4H pin	14
• Changed title of <i>Negative Voltage Sensing</i> section to <i>Sensing Voltage Less Than 0.4V</i>	20

PACKAGING INFORMATION

Orderable Device	Status ⁽¹⁾	Package Type	Package Drawing	Pins	Package Qty	Eco Plan ⁽²⁾	Lead/ Ball Finish	MSL Peak Temp ⁽³⁾	Samples (Requires Login)
TPS386000RGPR	ACTIVE	QFN	RGP	20	3000	Green (RoHS & no Sb/Br)	CU NIPDAU	Level-2-260C-1 YEAR	
TPS386000RGPT	ACTIVE	QFN	RGP	20	250	Green (RoHS & no Sb/Br)	CU NIPDAU	Level-2-260C-1 YEAR	
TPS386040RGPR	ACTIVE	QFN	RGP	20	3000	Green (RoHS & no Sb/Br)	CU NIPDAU	Level-2-260C-1 YEAR	
TPS386040RGPT	ACTIVE	QFN	RGP	20	250	Green (RoHS & no Sb/Br)	CU NIPDAU	Level-2-260C-1 YEAR	
TPS386060RGPR	PREVIEW	QFN	RGP	20	3000	TBD	Call TI	Call TI	
TPS386060RGPT	PREVIEW	QFN	RGP	20	250	TBD	Call TI	Call TI	

⁽¹⁾ The marketing status values are defined as follows:

ACTIVE: Product device recommended for new designs.

LIFEBUY: TI has announced that the device will be discontinued, and a lifetime-buy period is in effect.

NRND: Not recommended for new designs. Device is in production to support existing customers, but TI does not recommend using this part in a new design.

PREVIEW: Device has been announced but is not in production. Samples may or may not be available.

OBSOLETE: TI has discontinued the production of the device.

⁽²⁾ Eco Plan - The planned eco-friendly classification: Pb-Free (RoHS), Pb-Free (RoHS Exempt), or Green (RoHS & no Sb/Br) - please check <http://www.ti.com/productcontent> for the latest availability information and additional product content details.

TBD: The Pb-Free/Green conversion plan has not been defined.

Pb-Free (RoHS): TI's terms "Lead-Free" or "Pb-Free" mean semiconductor products that are compatible with the current RoHS requirements for all 6 substances, including the requirement that lead not exceed 0.1% by weight in homogeneous materials. Where designed to be soldered at high temperatures, TI Pb-Free products are suitable for use in specified lead-free processes.

Pb-Free (RoHS Exempt): This component has a RoHS exemption for either 1) lead-based flip-chip solder bumps used between the die and package, or 2) lead-based die adhesive used between the die and leadframe. The component is otherwise considered Pb-Free (RoHS compatible) as defined above.

Green (RoHS & no Sb/Br): TI defines "Green" to mean Pb-Free (RoHS compatible), and free of Bromine (Br) and Antimony (Sb) based flame retardants (Br or Sb do not exceed 0.1% by weight in homogeneous material)

⁽³⁾ MSL, Peak Temp. -- The Moisture Sensitivity Level rating according to the JEDEC industry standard classifications, and peak solder temperature.

Important Information and Disclaimer: The information provided on this page represents TI's knowledge and belief as of the date that it is provided. TI bases its knowledge and belief on information provided by third parties, and makes no representation or warranty as to the accuracy of such information. Efforts are underway to better integrate information from third parties. TI has taken and continues to take reasonable steps to provide representative and accurate information but may not have conducted destructive testing or chemical analysis on incoming materials and chemicals. TI and TI suppliers consider certain information to be proprietary, and thus CAS numbers and other limited information may not be available for release.

In no event shall TI's liability arising out of such information exceed the total purchase price of the TI part(s) at issue in this document sold by TI to Customer on an annual basis.

OTHER QUALIFIED VERSIONS OF TPS386000 :

- Automotive: [TPS386000-Q1](#)

NOTE: Qualified Version Definitions:

- Automotive - Q100 devices qualified for high-reliability automotive applications targeting zero defects

TAPE AND REEL INFORMATION

QUADRANT ASSIGNMENTS FOR PIN 1 ORIENTATION IN TAPE

*All dimensions are nominal

Device	Package Type	Package Drawing	Pins	SPQ	Reel Diameter (mm)	Reel Width W1 (mm)	A0 (mm)	B0 (mm)	K0 (mm)	P1 (mm)	W (mm)	Pin1 Quadrant
TPS386000RGPR	QFN	RGP	20	3000	330.0	12.4	4.25	4.25	1.15	8.0	12.0	Q2
TPS386000RGPT	QFN	RGP	20	250	180.0	12.4	4.25	4.25	1.15	8.0	12.0	Q2
TPS386040RGPR	QFN	RGP	20	3000	330.0	12.4	4.25	4.25	1.15	8.0	12.0	Q2
TPS386040RGPT	QFN	RGP	20	250	180.0	12.4	4.25	4.25	1.15	8.0	12.0	Q2

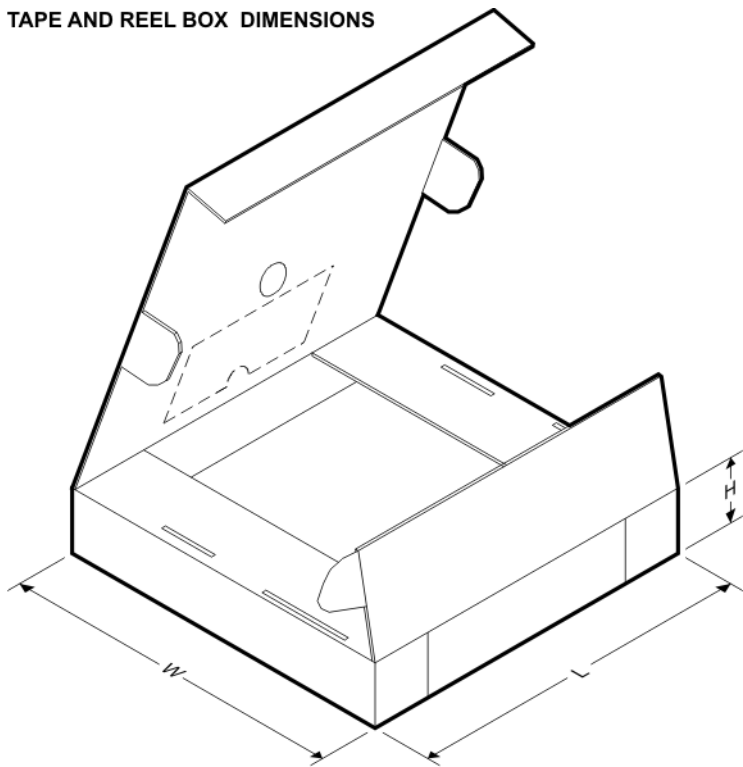
TAPE AND REEL BOX DIMENSIONS

*All dimensions are nominal

Device	Package Type	Package Drawing	Pins	SPQ	Length (mm)	Width (mm)	Height (mm)
TPS386000RGPR	QFN	RGP	20	3000	346.0	346.0	29.0
TPS386000RGPT	QFN	RGP	20	250	190.5	212.7	31.8
TPS386040RGPR	QFN	RGP	20	3000	346.0	346.0	29.0
TPS386040RGPT	QFN	RGP	20	250	190.5	212.7	31.8

RGP (S-PQFP-N20)

PLASTIC QUAD FLATPACK

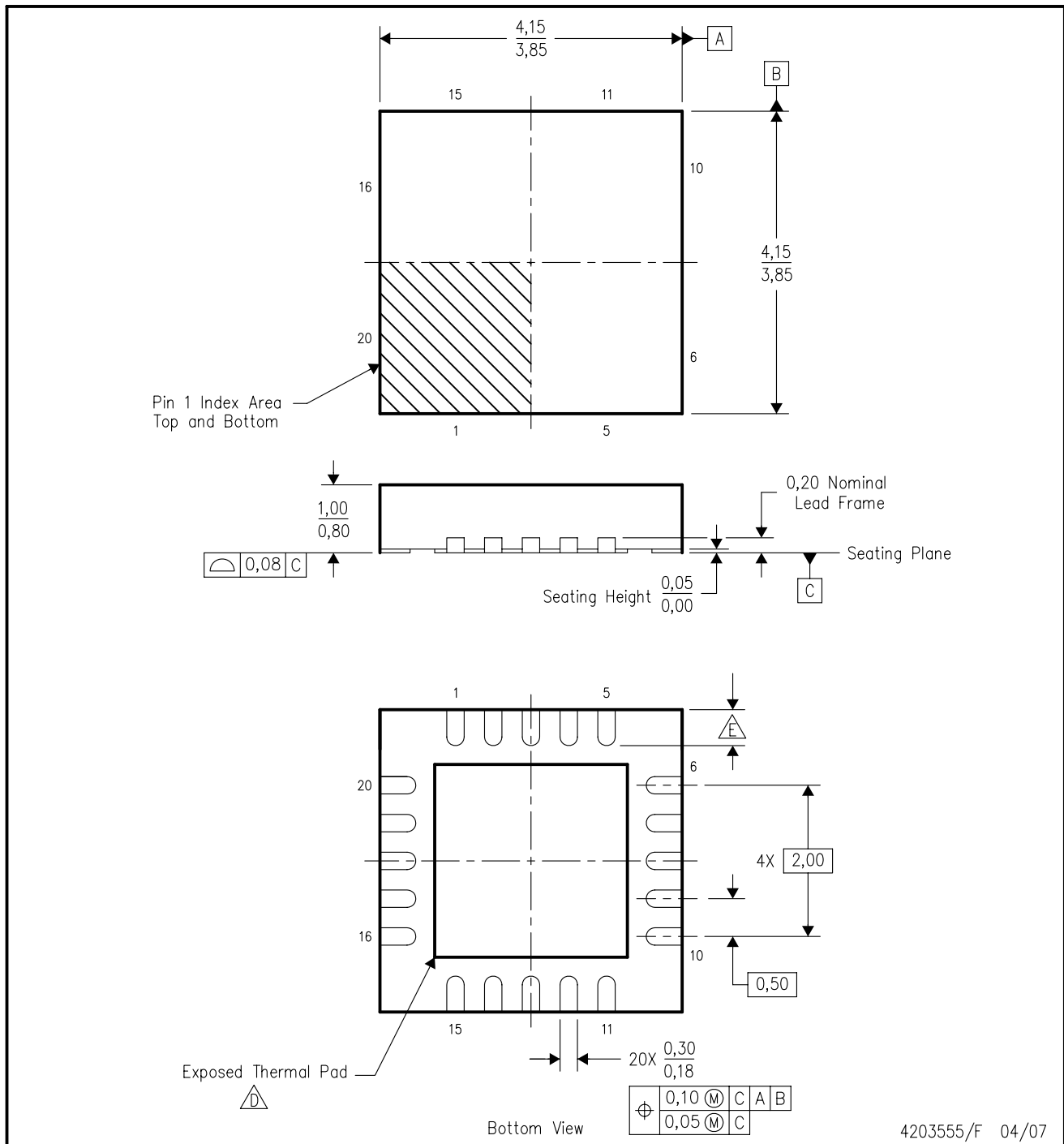

- NOTES:
- A. All linear dimensions are in millimeters. Dimensioning and tolerancing per ASME Y14.5M-1994.
 - B. This drawing is subject to change without notice.
 - C. QFN (Quad Flatpack No-Lead) package configuration.
 - The package thermal pad must be soldered to the board for thermal and mechanical performance. See the Product Data Sheet for details regarding the exposed thermal pad dimensions.
 - Check thermal pad mechanical drawing in the product datasheet for nominal lead length dimensions.

THERMAL PAD MECHANICAL DATA

RGP (S-PVQFN-N20)

PLASTIC QUAD FLATPACK NO-LEAD

THERMAL INFORMATION

This package incorporates an exposed thermal pad that is designed to be attached directly to an external heatsink. The thermal pad must be soldered directly to the printed circuit board (PCB). After soldering, the PCB can be used as a heatsink. In addition, through the use of thermal vias, the thermal pad can be attached directly to the appropriate copper plane shown in the electrical schematic for the device, or alternatively, can be attached to a special heatsink structure designed into the PCB. This design optimizes the heat transfer from the integrated circuit (IC).

For information on the Quad Flatpack No-Lead (QFN) package and its advantages, refer to Application Report, QFN/SON PCB Attachment, Texas Instruments Literature No. SLUA271. This document is available at www.ti.com.

The exposed thermal pad dimensions for this package are shown in the following illustration.

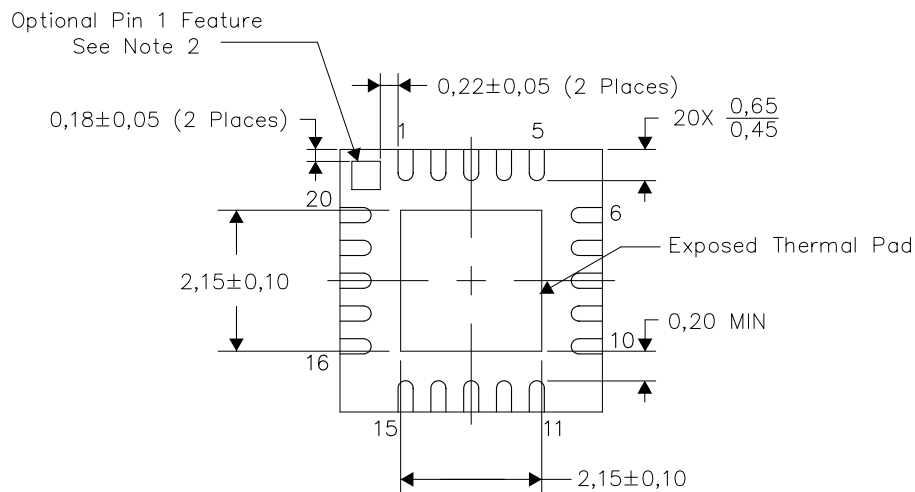

Exposed Thermal Pad Dimensions

4206346-2/V 04/11

NOTES: A. All linear dimensions are in millimeters

- B. The Pin 1 Identification mark is an optional feature that may be present on some devices. In addition, this Pin 1 feature if present is electrically connected to the center thermal pad and therefore should be considered when routing the board layout.

IMPORTANT NOTICE

Texas Instruments Incorporated and its subsidiaries (TI) reserve the right to make corrections, modifications, enhancements, improvements, and other changes to its products and services at any time and to discontinue any product or service without notice. Customers should obtain the latest relevant information before placing orders and should verify that such information is current and complete. All products are sold subject to TI's terms and conditions of sale supplied at the time of order acknowledgment.

TI warrants performance of its hardware products to the specifications applicable at the time of sale in accordance with TI's standard warranty. Testing and other quality control techniques are used to the extent TI deems necessary to support this warranty. Except where mandated by government requirements, testing of all parameters of each product is not necessarily performed.

TI assumes no liability for applications assistance or customer product design. Customers are responsible for their products and applications using TI components. To minimize the risks associated with customer products and applications, customers should provide adequate design and operating safeguards.

TI does not warrant or represent that any license, either express or implied, is granted under any TI patent right, copyright, mask work right, or other TI intellectual property right relating to any combination, machine, or process in which TI products or services are used. Information published by TI regarding third-party products or services does not constitute a license from TI to use such products or services or a warranty or endorsement thereof. Use of such information may require a license from a third party under the patents or other intellectual property of the third party, or a license from TI under the patents or other intellectual property of TI.

Reproduction of TI information in TI data books or data sheets is permissible only if reproduction is without alteration and is accompanied by all associated warranties, conditions, limitations, and notices. Reproduction of this information with alteration is an unfair and deceptive business practice. TI is not responsible or liable for such altered documentation. Information of third parties may be subject to additional restrictions.

Resale of TI products or services with statements different from or beyond the parameters stated by TI for that product or service voids all express and any implied warranties for the associated TI product or service and is an unfair and deceptive business practice. TI is not responsible or liable for any such statements.

TI products are not authorized for use in safety-critical applications (such as life support) where a failure of the TI product would reasonably be expected to cause severe personal injury or death, unless officers of the parties have executed an agreement specifically governing such use. Buyers represent that they have all necessary expertise in the safety and regulatory ramifications of their applications, and acknowledge and agree that they are solely responsible for all legal, regulatory and safety-related requirements concerning their products and any use of TI products in such safety-critical applications, notwithstanding any applications-related information or support that may be provided by TI. Further, Buyers must fully indemnify TI and its representatives against any damages arising out of the use of TI products in such safety-critical applications.

TI products are neither designed nor intended for use in military/aerospace applications or environments unless the TI products are specifically designated by TI as military-grade or "enhanced plastic." Only products designated by TI as military-grade meet military specifications. Buyers acknowledge and agree that any such use of TI products which TI has not designated as military-grade is solely at the Buyer's risk, and that they are solely responsible for compliance with all legal and regulatory requirements in connection with such use.

TI products are neither designed nor intended for use in automotive applications or environments unless the specific TI products are designated by TI as compliant with ISO/TS 16949 requirements. Buyers acknowledge and agree that, if they use any non-designated products in automotive applications, TI will not be responsible for any failure to meet such requirements.

Following are URLs where you can obtain information on other Texas Instruments products and application solutions:

Products

Audio	www.ti.com/audio
Amplifiers	amplifier.ti.com
Data Converters	dataconverter.ti.com
DLP® Products	www.dlp.com
DSP	dsp.ti.com
Clocks and Timers	www.ti.com/clocks
Interface	interface.ti.com
Logic	logic.ti.com
Power Mgmt	power.ti.com
Microcontrollers	microcontroller.ti.com
RFID	www.ti-rfid.com
RF/IF and ZigBee® Solutions	www.ti.com/lprf

Applications

Communications and Telecom	www.ti.com/communications
Computers and Peripherals	www.ti.com/computers
Consumer Electronics	www.ti.com/consumer-apps
Energy and Lighting	www.ti.com/energy
Industrial	www.ti.com/industrial
Medical	www.ti.com/medical
Security	www.ti.com/security
Space, Avionics and Defense	www.ti.com/space-avionics-defense
Transportation and Automotive	www.ti.com/automotive
Video and Imaging	www.ti.com/video
Wireless	www.ti.com/wireless-apps

TI E2E Community Home Page

e2e.ti.com

Mailing Address: Texas Instruments, Post Office Box 655303, Dallas, Texas 75265
Copyright © 2011, Texas Instruments Incorporated