

Features

- 1-channel isolated barrier
- 230 V AC supply
- Level sensing input
- Adjustable range 1 kΩ ... 150 kΩ
- Relay contact output
- Fault relay contact output
- Adjustable time delay up to 10 s
- Minimum/maximum control
- Line fault detection (LFD)

Function

This isolated barrier is used for intrinsic safety applications. It provides the AC measuring voltage for the level sensing electrodes.

Once the measured medium reaches the electrodes, the unit reacts by energizing a form C changeover relay contact.

The module is voltage and temperature stabilized and guarantees a defined switching characteristic.

It can be used for on/off control or minimum/maximum control. A signal delay feature is available and is adjustable between 0.5 s and 10 s.

This module can also monitor the field circuit for lead breakage (LB). LB is indicated by a red LED. If LB monitoring is selected, output II serves as the fault signal output; otherwise, it will follow the function of output I.

Application

The device is equipped with lead breakage detection (current free relay in event of failure). For this purpose, the enclosed 430 kΩ resistance must be switched between the maximum and reference electrode. This function can be deactivated by DIP switches.

Assembly

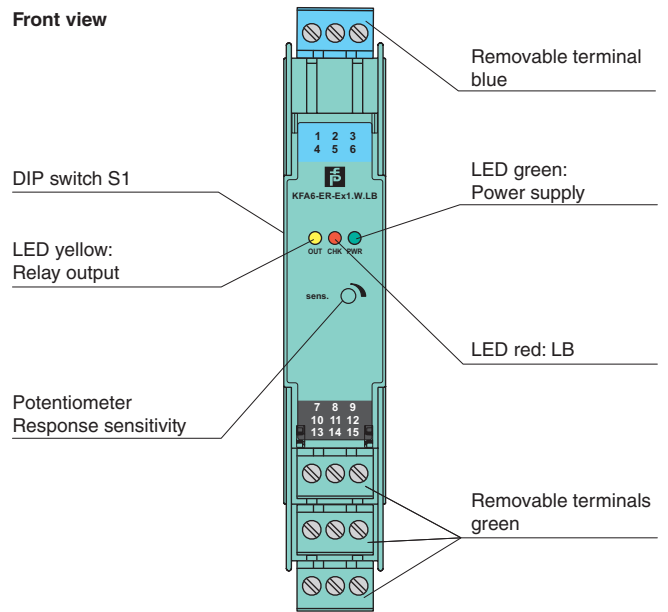

Connection

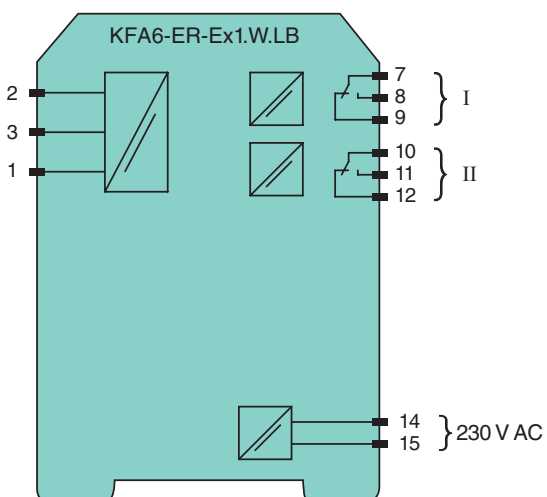
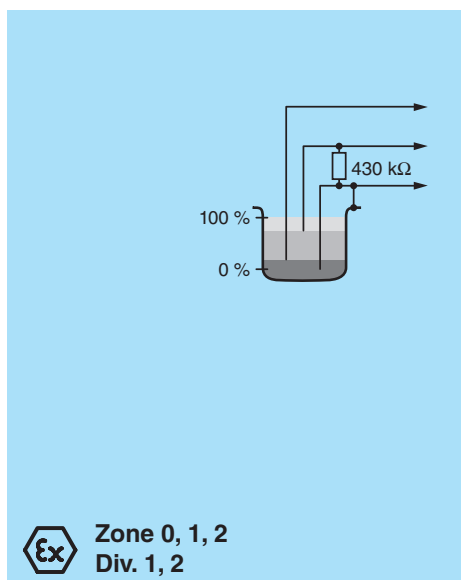

Release date 2012-09-26 14:52 Date of issue 2012-09-26 11:5163_eng.xml

General specifications	
Signal type	Digital Input
Supply	
Connection	terminals 14, 15
Rated voltage	207 ... 253 V AC, 45 ... 65 Hz
Rated current	≤ 7 mA
Power consumption	< 1.2 W
Input	
Connection	terminals 1 (mass), 2 (min), 3 (max)
Control input	min./max. control system: terminals 1, 2, 3 on/off control system: terminals 1, 3
Response sensitivity	1 ... 150 kΩ , adjustable via potentiometer
Output	
Connection	terminals 7, 8, 9; 10, 11, 12
Switching power	max. 192 W , 2000 VA
Output	signal ; relay
Time constant for signal damping	0.5 s, 2 s, 5 s, 10 s
Electrical isolation	
Output/power supply	basic insulation according to EN 50178, rated insulation voltage 253 V _{eff}
Directive conformity	
Electromagnetic compatibility	
Directive 2004/108/EC	EN 61326-1:2006
Low voltage	
Directive 2006/95/EC	EN 50178:1997
Conformity	
Insulation coordination	EN 50178:1997
Electrical isolation	EN 50178:1997
Electromagnetic compatibility	NE 21:2006
Protection degree	IEC 60529:2001
Ambient conditions	
Ambient temperature	-20 ... 60 °C (-4 ... 140 °F)
Mechanical specifications	
Protection degree	IP20
Connection	screw connection, max. 2.5 mm ²
Mass	approx. 150 g
Dimensions	20 x 119 x 115 mm (0.8 x 4.7 x 4.5 in) , housing type B2
Mounting	on 35 mm DIN mounting rail acc. to EN 60715:2001
Data for application in connection with Ex-areas	
EC-Type Examination Certificate	DMT 00 ATEX E 032 , for additional certificates see www.pepperl-fuchs.com
Group, category, type of protection	⊕ II (1)G [EEx ia] IIC [circuit(s) in zone 0/1/2]
Input	[EEx ia] IIC
Voltage U _o	10 V
Current I _o	2.5 mA
Power P _o	6 mW
Supply	
Maximum safe voltage U _m	265 V AC / 150 V AC (Attention! U _m is no rated voltage.)
Output	
Contact loading	253 V AC/2 A/cos φ > 0.7; 40 V DC/2 A resistive load
Electrical isolation	
Input/Output	safe galvanic isolation acc. to EN 50020, voltage peak value 375 V
Input/power supply	safe galvanic isolation acc. to EN 50020, voltage peak value 375 V
Directive conformity	
Directive 94/9/EC	EN 50014, EN 50020, EN 50284
General information	
Supplementary information	EC-Type Examination Certificate, Statement of Conformity, Declaration of Conformity, Attestation of Conformity and instructions have to be observed where applicable. For information see www.pepperl-fuchs.com .

Release date 2012-09-26 14:52 Date of issue 2012-09-26 11:5163_eng.xml

Configuration

DIP switch function on side of device

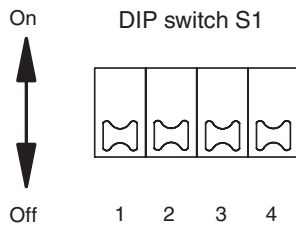

Switches	Position	Function
1	Off	open circuit current
	On	closed circuit current
2	Off	LB deactivated
	On	LB activated

Switch 3	Switch 4	Time constant for signal damping
Off	Off	0.5 s
Off	On	2 s
On	Off	5 s
On	On	10 s

- Open circuit current principle: In open circuit current principle the relay becomes active when the limit is reached.
- Closed circuit current principle: In closed circuit current principle, the relay is activated when power is applied. The relay is deactivated when the limit is reached.