

## Tiefspanner Form B

### Artikelbeschreibung/Produktabbildungen

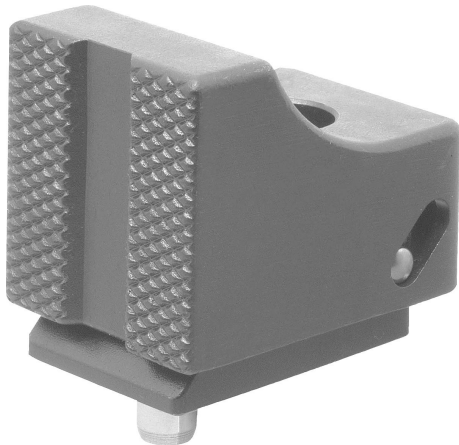

### Beschreibung

**Werkstoff:**  
Vergütungsstahl.

**Ausführung:**  
vergütet und brüniert.

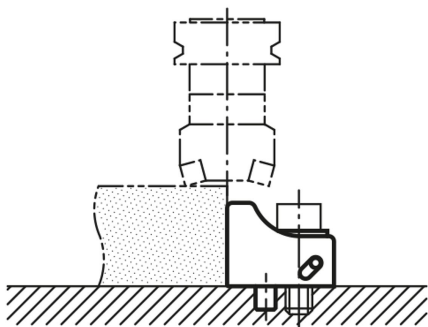

### Zeichnungen

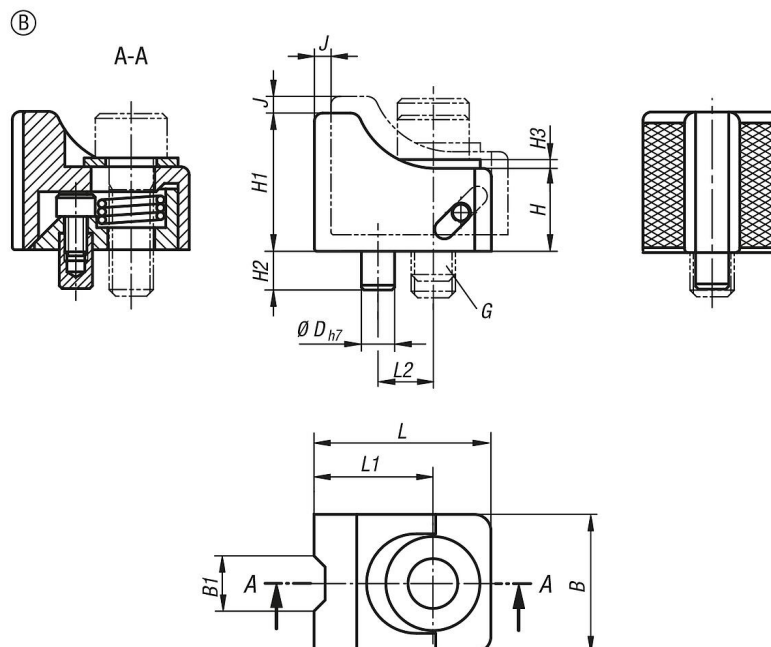

## Tiefspanner Form B

### Artikelübersicht

Bestellnummer	B	B1	D	G	H	H1	H2	H3	J	L	L1	L2	Spannkraft N	Anzieh- drehmoment Nm
K0932.0825	25	10	6	M8	15	25	7	1,6	3	32	21,5	10	7000	25
K0932.1032	30	11	6	M10	19	32	7	2	4	40	26	12	8500	50
K0932.1238	35	12	8	M12	23	38	10	2,3	5	50	33	16	20000	90
K0932.1645	40	14	10	M16	25	45	10	3,2	6	60	40	20	40000	200