



FEATURES

- 1. Even with small form factor, sensitive enough for direct IC-driving**
The dimensions of this high-density 4-gap balanced armature are 31 mm × 14 mm × 11 mm 1.220 inch × .551 inch × .433 inch. Despite this small size, high sensitivity is achieved by a mechanism that incorporates high-efficiency polarized magnetic circuits along with our exclusive spring alignment method. With an minimum operating power of about 150 mW, nominal operating power of 240 mW, this relay can be directly driven by transistor or chip controllers.
- 2. High switching capability**
Strong against lamp inductive loads, maximum switching capacity has reached 3,040 VA (8A 380V AC).

- 3. High breakdown voltage – Optimal for control in 250 V power circuits**
High breakdown voltage has been achieved. Between contacts and coil of 3,750 Vrms; Surge breakdown voltage between coil and contact of 6,000 V, and between open contacts of 1,200 Vrms mean that these relays are suitable even for 250 V power circuit control.
- 4. Improved stability**
Conforms to all types of safety standards.
Insulating distance of more than 3 mm secured. Complies with Japan Electrical Appliance and Material Safety Law requirements for operating 200 V power supply circuits, and conforms with UL, CSA and VDE standards.

- 5. Latching types available**
In addition to single side stable types, convenient 2 coil latching types with memory functions are also available. Moreover, we offer 2 Form A specifications which, with double pole switching for applications such as 250 V power circuit switching, can enable safer designs.

- 6. Automatic cleaning possible**
The sealed design means that these relays can undergo immersion in automatic washing systems and are suitable for automatic soldering. Even in difficult environments, the contacts remain reliable.
- 7. Easy to design PC board patterns**
Features 4/10 dual-in-line terminals. Because the lead spacing has a pitch greater than 7.54 mm .297 inch, designers can make easy adjustments with the width of the land size. This, along with the large insulation distance, simplifies the drawing of PC board patterns.
- 8. To improve soldering efficiency, preapplication of solder to the terminals is recommended.**

About Cd-free contacts

We have introduced Cadmium free type products to reduce Environmental Hazardous Substances. (The suffix "F" should be added to the part number)
Please replace parts containing Cadmium with Cadmium-free products and evaluate them with your actual application before use because the life of a relay depends on the contact material and load.

ORDERING INFORMATION

ST [] - [] - [] - F

Contact arrangement

1: 1 Form A 1 Form B

2: 2 Form A

Operating function

Nil: Single side stable

L2: 2 coil latching

Coil voltage

DC 3, 5, 6, 9, 12, 24, 48 V

Contact material

F: AgSnO₂ type contact

Note: UL/CSA, VDE, SEV type is standard.

TYPES

Contact arrangement	Nominal coil voltage	Single side stable	2 coil latching
		Part No.	Part No.
1 Form A 1 Form B	3V DC	ST1-DC3V-F	ST1-L2-DC3V-F
	5V DC	ST1-DC5V-F	ST1-L2-DC5V-F
	6V DC	ST1-DC6V-F	ST1-L2-DC6V-F
	9V DC	ST1-DC9V-F	ST1-L2-DC9V-F
	12V DC	ST1-DC12V-F	ST1-L2-DC12V-F
	24V DC	ST1-DC24V-F	ST1-L2-DC24V-F
	48V DC	ST1-DC48V-F	ST1-L2-DC48V-F
2 Form A	3V DC	ST2-DC3V-F	ST2-L2-DC3V-F
	5V DC	ST2-DC5V-F	ST2-L2-DC5V-F
	6V DC	ST2-DC6V-F	ST2-L2-DC6V-F
	9V DC	ST2-DC9V-F	ST2-L2-DC9V-F
	12V DC	ST2-DC12V-F	ST2-L2-DC12V-F
	24V DC	ST2-DC24V-F	ST2-L2-DC24V-F
	48V DC	ST2-DC48V-F	ST2-L2-DC48V-F

Standard packing: Tube: 50 pcs.; Case: 500 pcs.

RATING

1. Coil data

1) Single side stable

Nominal coil voltage	Pick-up voltage (at 20°C 68°F)	Drop-out voltage (at 20°C 68°F)	Nominal operating current [±10%] (at 20°C 68°F)	Coil resistance [±10%] (at 20°C 68°F)	Nominal operating power	Max. allowable voltage (at 20°C 68°F)
3V DC	80%V or less of nominal voltage (Initial)	10%V or more of nominal voltage (Initial)	75mA	38Ω	240mW	150%V of nominal voltage
5V DC			47mA	105Ω		
6V DC			40mA	150Ω		
9V DC			25mA	360Ω		
12V DC			20mA	600Ω		
24V DC			10mA	2,400Ω		
48V DC			4.7mA	9,000Ω		

2) 2 coil latching

Nominal coil voltage	Set voltage (at 20°C 68°F)	Reset voltage (at 20°C 68°F)	Nominal operating current [±10%] (at 20°C 68°F)		Coil resistance [±10%] (at 20°C 68°F)		Nominal operating power		Max. allowable voltage (at 20°C 68°F)
			Set coil	Reset coil	Set coil	Reset coil	Set coil	Reset coil	
3V DC	80%V or less of nominal voltage (Initial)	80%V or less of nominal voltage (Initial)	75mA	75mA	40Ω	40Ω	240mW	240mW	150%V of nominal voltage
5V DC			45mA	45mA	110Ω	110Ω			
6V DC			37.5mA	37.5mA	155Ω	155Ω			
9V DC			25mA	25mA	360Ω	360Ω			
12V DC			18.8mA	18.8mA	640Ω	640Ω			
24V DC			10mA	10mA	2,400Ω	2,400Ω			
48V DC			4.7mA	4.7mA	10,200Ω	10,200Ω			

2. Specifications

Characteristics	Item	Specifications	
Contact	Arrangement	1 Form A 1 Form B, 2 Form A	
	Contact material	Au-flashed AgSnO ₂ type	
Rating	Initial contact resistance, max.	Max. 30 mΩ (By voltage drop 6 V DC 1A)	
	Max. switching power (resistive load)	3,040 VA, 150 W	
	Max. switching voltage	380 V AC, 250 V DC	
	Max. switching current	8 A	
	Minimum operating power	150mW (Single side stable, 2 coil latching)	
	Nominal operating power	240mW (Single side stable, 2 coil latching)	
	Min. switching capacity (Reference value)*1	100 mA 5V DC	
Electrical characteristics	Insulation resistance (Initial) (at 25°C, 50% relative humidity)	Min. 1,000MΩ (at 500V DC) Measurement at same location as "Initial breakdown voltage" section.	
	Breakdown voltage (Initial)	Between open contacts	1,200 Vrms for 1 min. (Detection current: 10 mA)
		Between contact sets	2,000 Vrms for 1 min. (Detection current: 10 mA)
		Between contact and coil	3,750 Vrms for 1 min. (Detection current: 10 mA)
	Surge breakdown voltage (Initial)*2	6,000 V (Between contact and coil)	
	Operate time [Set time] (at 20°C 68°F)	Max. 15 ms [Max. 15 ms] (Nominal voltage applied to the coil, excluding contact bounce time.)	
	Release time [Reset time] (at 20°C 68°F)	Max. 10 ms [Max. 15 ms] (Nominal voltage applied to the coil, excluding contact bounce time.) (without diode)	
Mechanical characteristics	Shock resistance	Functional	Min. 196 m/s ² (Half-wave pulse of sine wave: 11 ms; detection time: 10μs.)
		Destructive	Min. 980 m/s ² (Half-wave pulse of sine wave: 6 ms.)
	Vibration resistance	Functional	10 to 55 Hz at double amplitude of 2 mm (Detection time: 10μs.)
		Destructive	10 to 55 Hz at double amplitude of 3 mm
Expected life	Mechanical	Min. 10 ⁷ (at 180 cpm)	
	Electrical	Min. 10 ⁵ (8 A 250 V AC resistive) (ON : OFF = 1 s : 5 s)	
Conditions	Conditions for operation, transport and storage*3	Ambient temperature: -40°C to +60°C -40°F to +140°F; Humidity: 5 to 85% R.H. (Not freezing and condensing at low temperature)	
	Max. operating speed	20 cpm*4	
Unit weight		Approx. 10g .353 oz	

*1 This value can change due to the switching frequency, environmental conditions, and desired reliability level, therefore it is recommended to check this with the actual load.

*2 Wave is standard shock voltage of ±1.2×50μs according to JEC-212-1981.

*3 Refer to "6. Usage, Storage and Transport Conditions" in [AMBIENT ENVIRONMENT section in Relay Technical Information](#).

*4 The max. operating speed amounts to 30cps without load.

REFERENCE DATA

1. Max. switching power

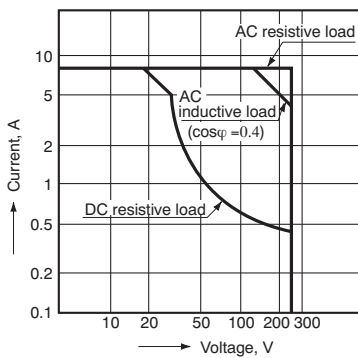

2. Coil temperature rise

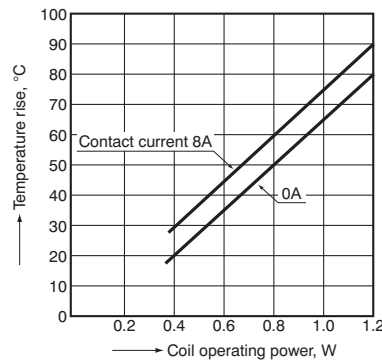

3. Influence of adjacent mounting

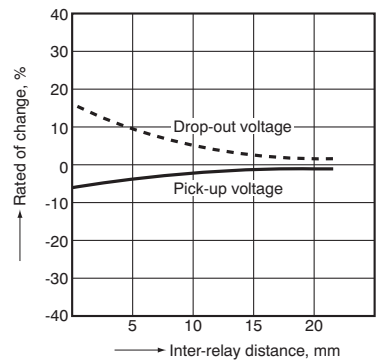

CAD Data



External dimensions

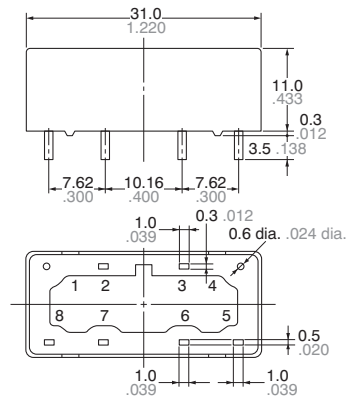

PC board pattern (Bottom view)

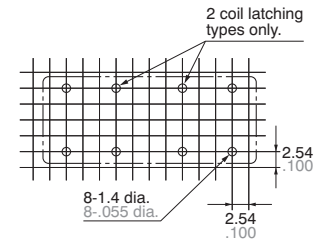

Tolerance: $\pm 0.1 \pm 0.004$

General tolerance: $\pm 0.5 \pm 0.020$

Schematic (Bottom view)

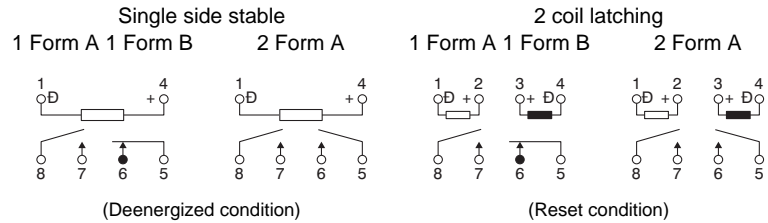

SAFETY STANDARDS

UL/C-UL (Recognized)		CSA (Certified)		VDE (Certified)		TV rating (UL/CSA)		SEV	
File No.	Contact rating	File No.	Contact rating	File No.	Contact rating	File No.	Rating	File No.	Contact rating
E43028	8A 250V AC 1/4HP 125, 250V AC 5A 30V DC	LR26550 etc.	8A 250V AC 1/4HP 125, 250V AC 5A 30V DC	1017	8A 250V AC (cos ϕ =1.0) 4A 250V AC (cos ϕ =0.4) 5A 30V DC	UL: E43028 CSA: LR26550	—	98-1 10289	8A 380V AC

NOTES

1. PC board patterns for 2 coil latching types

When applying relays in power supply operation circuits for finished products regulated by the Electrical Appliance and Material Safety Law, use the pattern shown below.

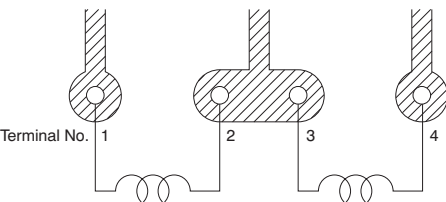

2. Soldering should be done under the following conditions:

- 1) 250°C 482°F within 10s
300°C 572°F within 5s
350°C 662°F within 3s
- 2) For automatic cleaning, the boiling method is recommended. Avoid ultrasonic cleaning which subjects the relays to high frequency vibrations, which may cause the contacts to stick. It is recommended that a fluorinated hydrocarbon or other alcoholic solvents be used.

3. When using, please be aware that the a contact and b contact sides of 1 Form A and 1 Form B types may go on simultaneously at operate time and release time.

For Cautions for Use, see [Relay Technical Information](#).

ACCESSORIES

ST RELAYS SOCKET

ST relay socket



ST-PS
PC board terminal socket

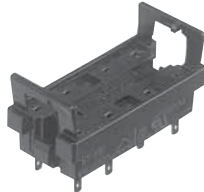

ST-SS
Solder terminal socket

FEATURES

1. Possible to fit or remove the chassis with one touch ($t = 0.6 \text{ mm}$ to 2.2 mm .024 inch to .087 inch)
2. Easy design of PC board pattern (2.54 mm x 4 pitch DIL terminal array)
3. Complies with Japan Electrical Appliance and Material Safety Law. (UL and VDE certification)
4. High breakdown voltage.

SPECIFICATIONS

Item	Specifications
Breakdown voltage (Initial)	Between contact and coil: 4,000 Vrms for 1 min. (Detection current: 10 mA) Between contact and terminal: 2,000 Vrms for 1 min.
Insulation resistance (Initial)	Min. 1,000 MΩ between terminals (500V DC)
Heat resistance	150°C 302°F for 1 hr
Max. continuous current	10 A
Relay insertion life	15 times

DIMENSIONS (Unit: mm inch)

ST-PS

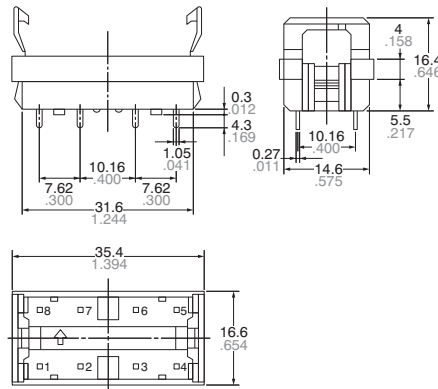

ST-SS

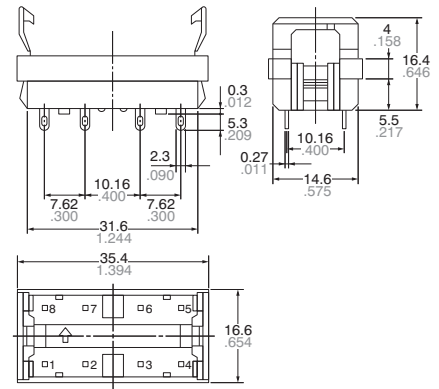

PRECAUTIONS FOR USE (SOCKET)

1. PC board mounting method

PC board pattern

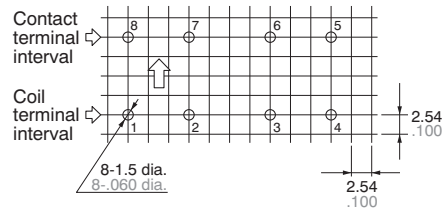

The terminal configuration is symmetrical on the left and right, so an arrow mark \uparrow is stamped on the socket to prevent mis-insertion. We recommend printing the same arrow mark \uparrow on the component mounting side (side opposite from pattern) of the PC board. In this case, the terminal configuration becomes the terminal nos. noted near the drilling holes.

2. Chassis cutout

Chassis cutting dimensions

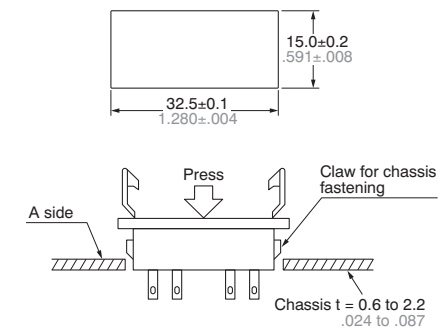

If the chassis hole is punched with a press, set so the release R on the front side (A side). The range for chassis thickness is 0.6 to 2.2 mm .024 to .087 inch.

3. Relay mounting and removal

(1) Align the directions of the relay and socket.

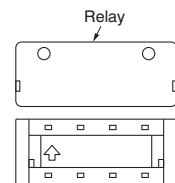

(2) Insert the relay all the way in, so it is securely in place.

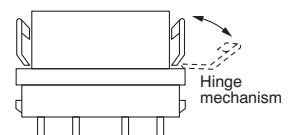

(3) Press the part indicated by A in the B direction, and fasten by placing the hook on the relay.

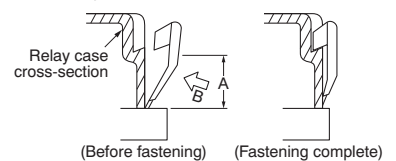

(4) When removing the relay, completely release the hooks on both sides and pull the relay out.