

CR-1025

DIMENSIONS (MM)

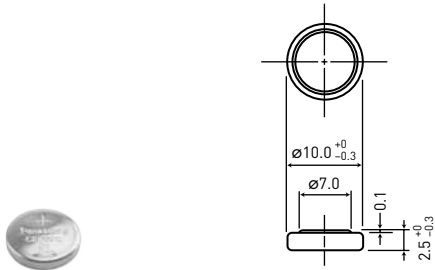

| | |
|------------------------------------|------------|
| Model number | CR-1025 |
| Nominal voltage (V) | 3 |
| Nominal capacity (mAh) | 30 |
| Diameter (mm) | 10.0 |
| Total height (mm) | 2.5 |
| Discharging temperature range (°C) | -30 to +60 |
| Weight (g) | 0.7 |

DISCHARGE TEMPERATURE CHARACTERISTICS

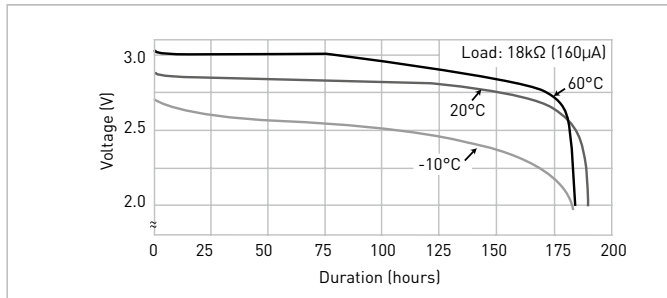

OPERATING VOLTAGE VS. DISCHARGE CURRENT*1

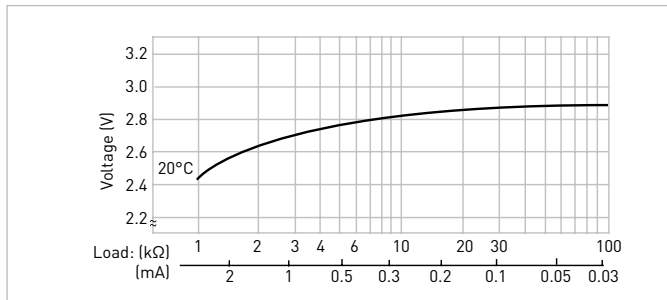

CAPACITY VS. LOAD RESISTANCE

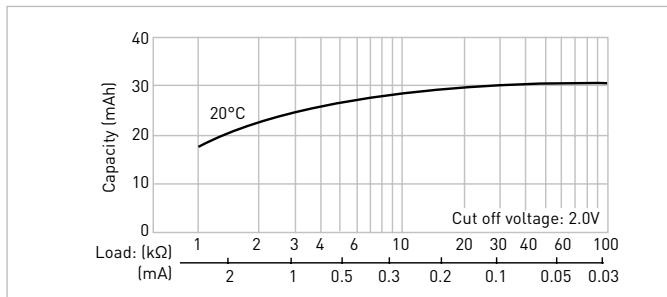

CR-1216

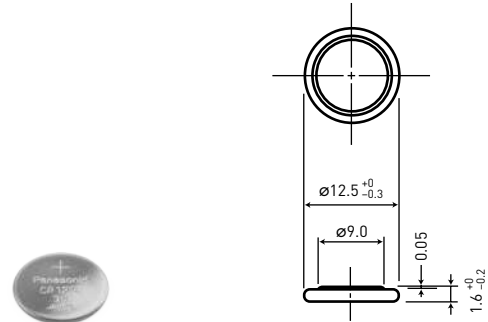

| | |
|------------------------------------|------------|
| Model number | CR-1216 |
| Nominal voltage (V) | 3 |
| Nominal capacity (mAh) | 25 |
| Diameter (mm) | 12.5 |
| Total height (mm) | 1.6 |
| Discharging temperature range (°C) | -30 to +60 |
| Weight (g) | 0.7 |

DISCHARGE TEMPERATURE CHARACTERISTICS

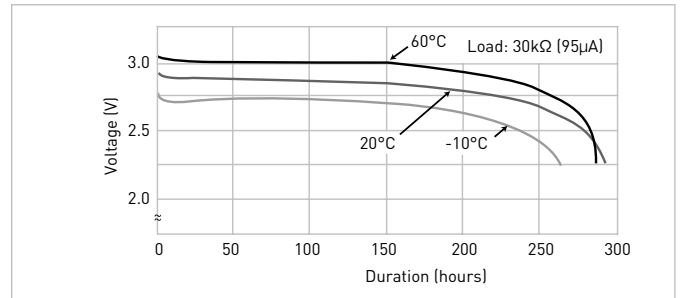

OPERATING VOLTAGE VS. DISCHARGE CURRENT*1

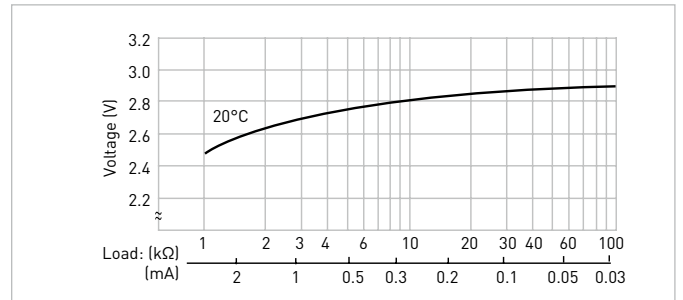

CAPACITY VS. LOAD RESISTANCE

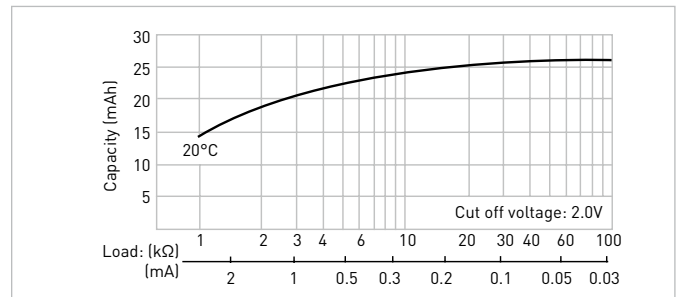

The data in this document are for descriptive purposes only and are not intended to make or imply any guarantee or warranty.

*1 Voltage at 50% discharge depth.