

Skillair® LUBRICATOR

The pneumatic lubricator is the simplest way of properly lubricating actuators connected to a circuit.

As air flows from the mains through the lubricator, it encounters the diaphragm which obstructs the flow and the air is forced through the Venturi tube.

The inside of the Venturi tube is connected to the inspection dome, which connects with the bowl via a tube with a regulating needle in between.

The drop in pressure caused by the Venturi tube sucks up air through the dome, the tube and lastly into the bowl containing oil.

The quantity of oil controlled by the regulating needle then flows back from the bowl to the circuit.



TECHNICAL DATA	LUB 100		LUB 200			LUB 300			LUB 400			
	1/4"	3/8"	1/4"	3/8"	1/2"	1/2"	3/4"	1"	1"	1 1/4"	1 1/2"	2"
Threaded port	1/4"	3/8"	1/4"	3/8"	1/2"	1/2"	3/4"	1"	1"	1 1/4"	1 1/2"	2"
Type of lubrication	Mist		Mist			Mist			Mist			
Bowl capacity	50		95			160			800			
Versions	Standard - CD		Standard - CD			Standard - CD - ML CD			Standard - CD - ML CD			
Max. inlet pressure	Mpa	1.5	1.3			1.3			1.3		1.3	
	bar	15	13			13			13		13	
	psi	217	188			188			188		188	
Flow rate at 6.3 bar (0.63 MPa to 91 psi)	Nl/min	1100	2200			3500			18000		21000	
ΔP 0.5 bar (0.05 MPa to 7 psi)	scfm	39	71			125			640		750	
Flow rate at 6.3 bar (0.63 MPa to 91 psi)	Nl/min	1500	3700			5500			-		-	
ΔP 1 bar (0.1 MPa to 14 psi)	scfm	53	131			196			-		-	
Max temperature at: 1 MPa; 10 bar; 145 psi	°C	50	50			50			50		50	
	°F	122	122			122			122		122	
Weight	Kg	0.4	0.7			1.4			4.9		5.7	
Wall fixing screws		M4 x 50	M5 x 60			M5 x 70			M6 x 110		M6 x 110	
Mounting position		Vertical										
Fluid		Filtered compressed air										
Recommended oils		ISO and UNI FD22 (Energol HPL to Spinesso to Mobil DTE to Tellus Oil).										
Notes on use		Install the lubricator as close as possible to the point of use. Fill the lubricator bowl with oil before pressurizing the system. Do not use cleaning oils, brake fluid oils or solvents in general. For the best lubrication results, set the drip rate to one drop per 300-600 Nl.										

COMPONENTS LUB 100 - LUB 200 - LUB 300

- ① Technopolymer body
- ② Bowl: technopolymer for LUB 100 and 200, metal for LUB 300
- ③ Technopolymer plug
- ④ Clear technopolymer glass
- ⑤ NBR Venturi tube diaphragm
- ⑥ Rilsan® oil suction tube
- ⑦ Filter
- ⑧ Clear technopolymer inspection dome
- ⑨ OT58 brass oil flow regulating needle
- ⑩ OT58 brass oil filling plug
- ⑪ Zamak end plate
- ⑫ NBR gaskets

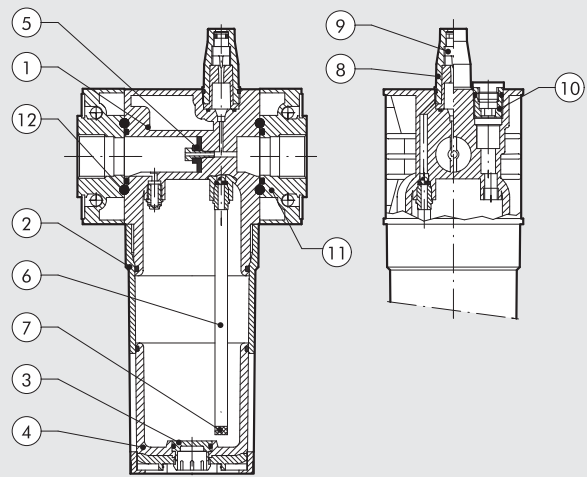

COMPONENTS LUB 400

- ① Aluminium body
- ② Aluminium bowl
- ③ Clear technopolymer glass
- ④ NBR Venturi tube diaphragm
- ⑤ Aluminium end plate
- ⑥ OT58 brass retaining ring
- ⑦ OT48 brass threaded bush with axial adjustment
- ⑧ Rilsan® oil suction pipe
- ⑨ Filter
- ⑩ Technopolymer plug
- ⑪ Clear technopolymer inspection dome
- ⑫ OT58 brass oil flow regulating needle
- ⑬ OT58 brass oil filling plug
- ⑭ NBR gaskets

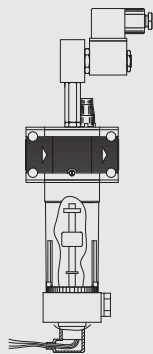
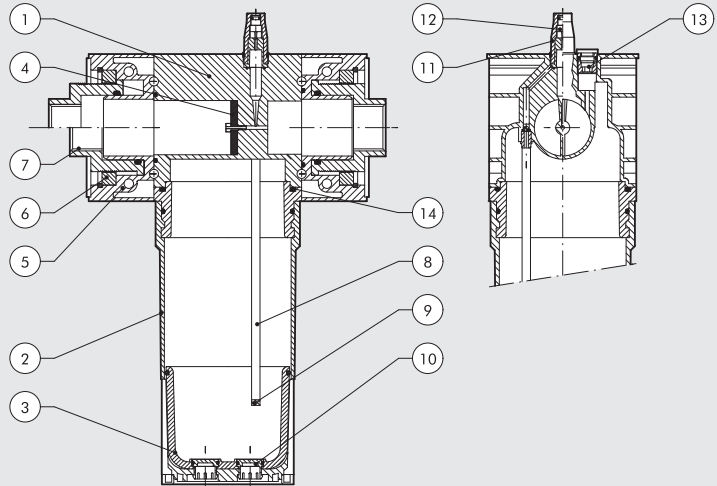

DEPRESSION FILLING WITH MINIMUM LEVEL (ML CD AUTOMATIC)

Available in sizes 300 and 400, this lubricator is controlled by a solenoid valve (2/2 NC minimum bore 3) situated on the lubricator body. It reduces pressure inside the bowl allow it to be filled with oil taken from a tank at ambient pressure, which can be located in a lower position than the lubricator (max. difference in height 2 m). The electric indicator inside the bowl sends an electric signal used to activate the valve. When the oil reaches the maximum level, another signal disactivates the valve. In this case, the lubricator system operates with the oil level between minimum and maximum. If it is necessary to keep the oil level in the bowl constant, only one of the two signals can be used. Pressure range 3-10 bar. Connect the oil tank to the G1/4 fitting on the bowl.

Constant minimum level

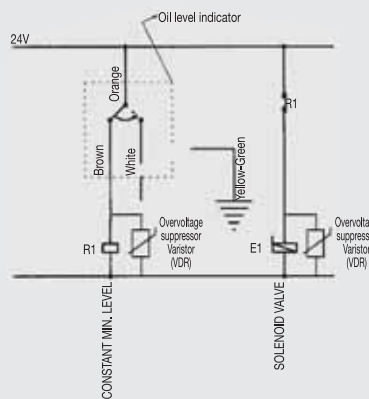

Constant maximum level

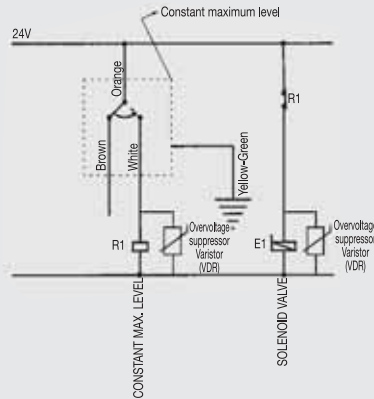

Oil level between maximum and minimum

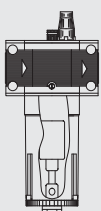
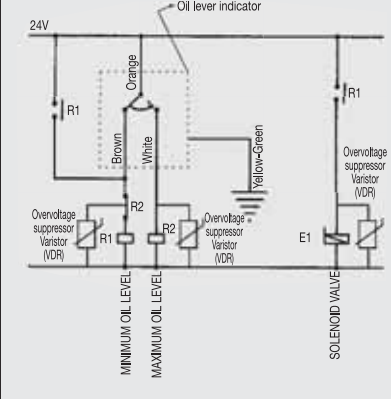

FILLING BY DEPRESSION (CD MANUAL)

Available in all sizes. It is operated by means of a button on the lubricator body. The pressure inside the bowl drops to allow it to be filled with oil taken from a tank at ambient pressure, which can be located in a lower position than the lubricator (max. difference in height 2 m). Oil filling stops when the level of oil raises the float and shuts off a specific valve. Important - The SK4 lubricator is filled with oil by hand. Filling must stop when the oil level is visible through the spy-hole in the bowl release lever. Pressure range 3-10 bar. Lubrication is discontinued during filling. Connect the oil tank to the G1/4 fitting below the bowl.

FLOW CHARTS

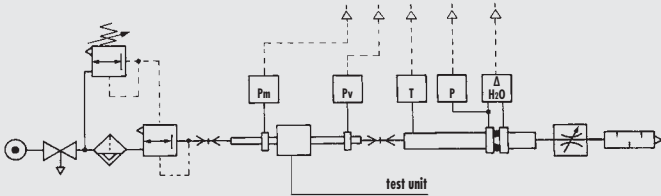

• Flow tests carried out at the Department of Mechanics, Turin Polytechnic, using the computerized test bench following CETOP RP50R recommendations (ISO DIS 6358-2-approved) with ISO 5167 diaphragm gauge.

- (A) = 2 bar - 0.2 MPa - 29 psi
- (B) = 4 bar - 0.4 MPa - 58 psi
- (C) = 6 bar - 0.6 MPa - 87 psi
- (D) = 8 bar - 0.8 MPa - 116 psi
- (E) = 10 bar - 1 MPa - 145 psi

LUB 100 1/4 - 3/8

$\Delta P = (P_m - P_v)$
psi kPa bar

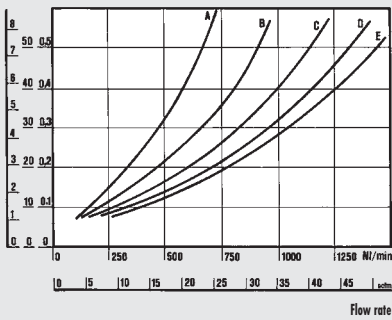

MINIMUM OPERATING FLOW CHART

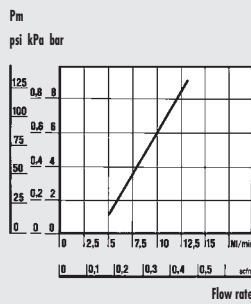

LUB 400 1"

$\Delta P = (P_m - P_v)$
psi kPa bar

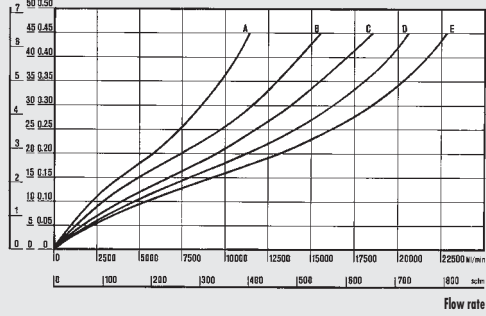

LUB 200 1/4 - 3/8 - 1/2

$\Delta P = (P_m - P_v)$
psi kPa bar

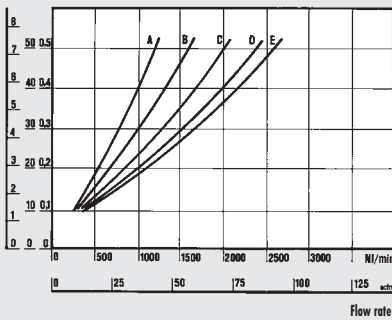

MINIMUM OPERATING FLOW CHART

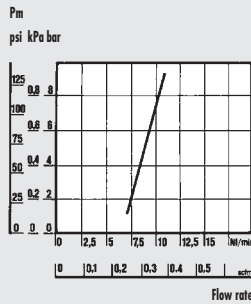

LUB 400 2"

$\Delta P = (P_m - P_v)$
psi kPa bar

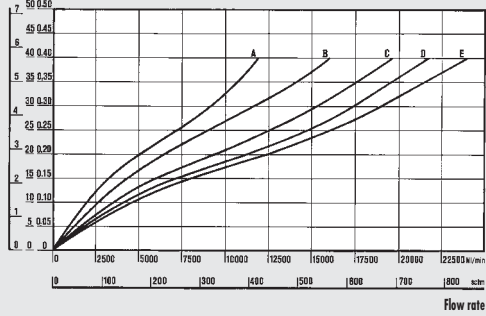

LUB 300 1/2 - 3/4 - 1

$\Delta P = (P_m - P_v)$
psi kPa bar

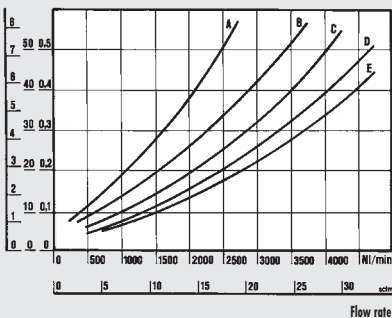

MINIMUM OPERATING FLOW CHART

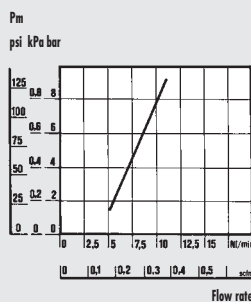

MINIMUM OPERATING FLOW CHART LUB 400 1" AND 2"

PRESSURE
psi kPa bar

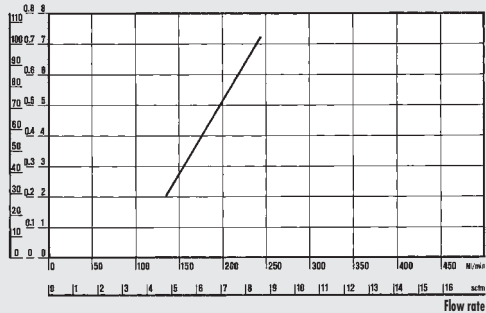

DIMENSIONS

100 - 200 - 300

400

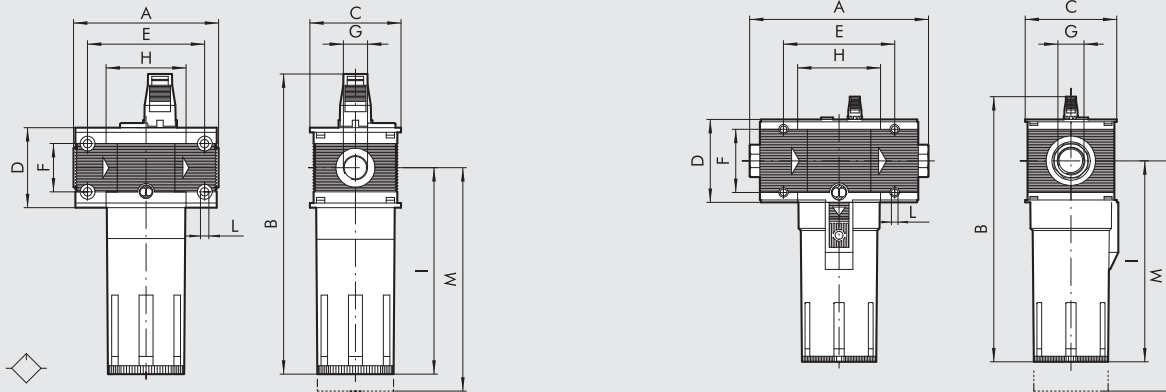

	LUB 100		LUB 200			LUB 300			LUB 400			
Threaded port G	1/4"	3/8"	1/4"	3/8"	1/2"	1/2"	3/4"	1"	1"	1 1/4"	1 1/2"	2"
A	78		93.5			110		112	225 to 255			283 to 313
B	162		193			214			338			
C	50		63			72			116			
D	43		55			65			105			
E	63		78.5			92			141.4			
F	26		36			42			80			
H	43		55.5			65			105.4			
I	112		137.5			153			256			
L	M4 hole		M5 hole			M5 hole			M6 hole			
M	130		150			160			285			

SYNOPTIC, SIZES AND VERSIONS

LUB ELEMENT	100 SIZE	1/4 THREADED PORT	- TYPE OF OIL FILLING
LUB	100	1/4	- = STD
	200	3/8	ML-CD = AUTOMATIC
		1/4	CD = MANUAL
	300	3/8	
		1/2	
	400	1/2	
		3/4	
		1	
		1	
		1 1/4	
		1 1/2	
		2	

STD: Standard version filled with oil by removing the bowl or through the top cap. Requires circuit relieving.
 ML CD: Depression filling with minimum level and valve
 CD MANUAL: Filling by depression.

ORDERING CODES

Code	Description	Code	Description	Code	Description
Skillair® 100 LUBRICATOR		Skillair® 300 LUBRICATOR		Skillair® 400 LUBRICATOR	
3281001A	LUB 100 without end plates	4481001A	LUB 300 without end plates	6181001A	LUB 400 without end plates
3281005A	LUB 100 CD manual without end plates	4481005A	LUB 300 CD manual without end plates	6181004A	LUB 400 CD manual without end plates
3281001	LUB 100 1/4	4481006A	LUB 300 ML-CD automatic without end plates	6181006A	LUB 400 ML-CD automatic without end plates
3281005	LUB 100 1/4 CD manual	4481001	LUB 300 1/2	6181001	LUB 400 1
3381001	LUB 100 3/8	4481005	LUB 300 1/2 CD manual	6181004	LUB 400 1 CD manual
3381005	LUB 100 3/8 CD manual	4481006	LUB 300 1/2 ML-CD automatic	6181006	LUB 400 1 ML-CD automatic
Skillair® 200 LUBRICATOR		4581001	LUB 300 3/4	6281001	LUB 400 1 1/4
3481001A	LUB 200 without end plates	4581005	LUB 300 3/4 CD manual	6281004	LUB 400 1 1/4 CD manual
3481005A	LUB 200 CD manual without end plates	4581006	LUB 300 3/4 ML-CD automatic	6281006	LUB 400 1 1/4 ML-CD automatic
3481001	LUB 200 1/4	4681001	LUB 300 1	6381001	LUB 400 1 1/2
3481005	LUB 200 1/4 CD manual	4681005	LUB 300 1 CD manual	6381004	LUB 400 1 1/2 CD manual
3581001	LUB 200 3/8	4681006	LUB 300 1 ML-CD automatic	6381006	LUB 400 1 1/2 ML-CD automatic
3581005	LUB 200 3/8 CD manual			6481001	LUB 400 2
3681001	LUB 200 1/2			6481004	LUB 400 2 CD manual
3681005	LUB 200 1/2 CD manual			6481006	LUB 400 2 ML-CD automatic

UNITS
Skillair® LUBRICATOR