

## High-Precision Buffered Voltage Reference

### Features

- Maximum Temperature Coefficient: 7 ppm/°C from -40°C to +125°C
- Initial Accuracy: 0.1%
- Operating Temperature Range: -40°C to +125°C
- Low Typical Operating Current: 140 µA
- Line Regulation: 50 ppm/V Maximum
- Load Regulation: 40 ppm/V Maximum
- 8 Voltage Variants Available:
  - 1.024V
  - 1.250V
  - 1.800V
  - 2.048V
  - 2.500V
  - 3.000V
  - 3.300V
  - 4.096V
- Output Noise: 30 µV<sub>RMS</sub>, 0.1 Hz to 10 kHz (1.024V)
- AEC-Q100 Qualified (Automotive Applications)
  - (Grade 1) temperature range: -40°C to +125°C

### Applications

- Precision Data Acquisition Systems
- Electric Vehicle Battery Management Systems
- High-Resolution Data Converters
- Medical Equipment Applications
- Industrial Controls
- Battery-Powered Devices

### Related Parts

- [MCP1501: High-Precision Buffered Voltage Reference](#)

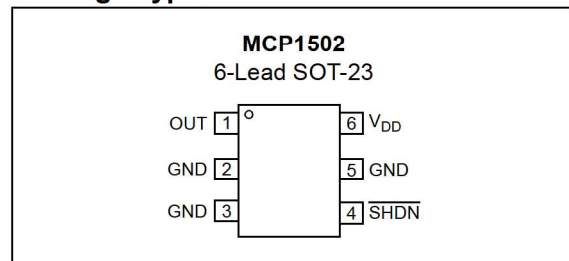
### General Description

The MCP1502 is a buffered voltage reference capable of sinking and sourcing 20 mA of current. The voltage reference is a low drift band gap-based reference. The band gap uses chopper-based amplifiers, effectively reducing the drift to zero.

The MCP1502 is available in the following package:

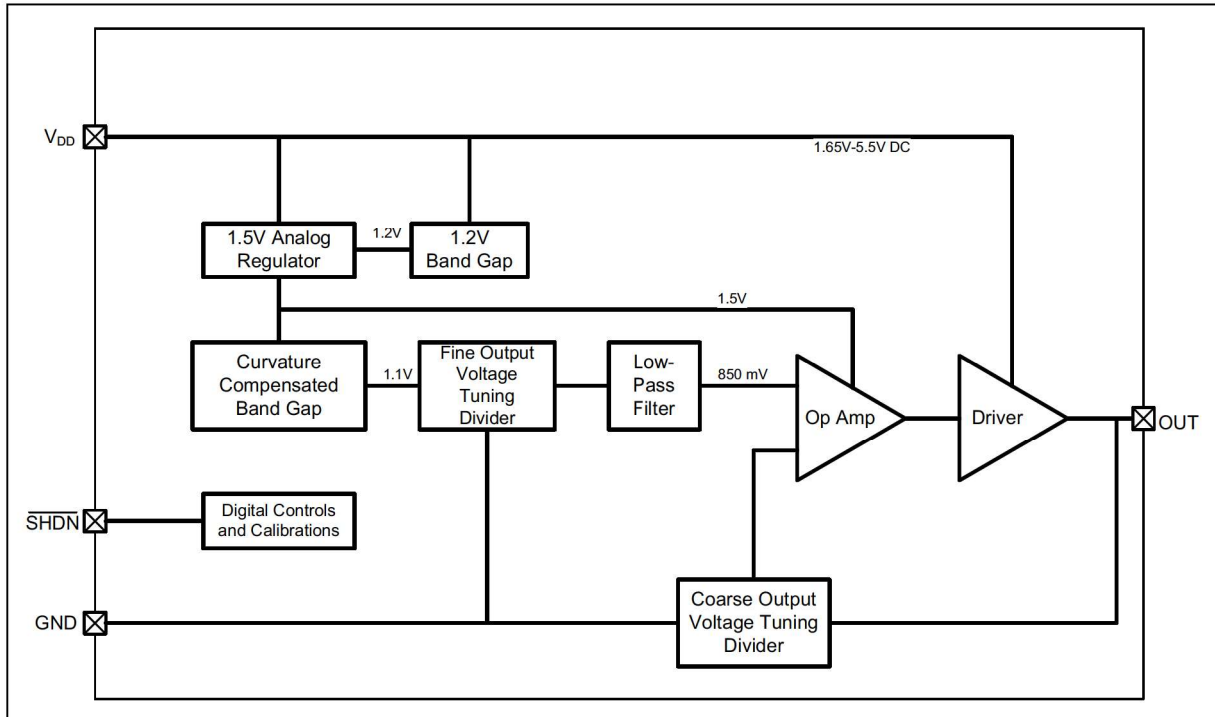
- 6-Lead SOT-23

### Package Types



# MCP1502

## BLOCK DIAGRAM



## 1.0 PIN FUNCTION TABLE

The pin functions are described in [Table 1-1](#).

**TABLE 1-1: PIN FUNCTION TABLE**

SOT-23	Symbol	Function
1	OUT	V <sub>REF</sub> Output
2, 3, 5	GND	System Ground
4	$\overline{\text{SHDN}}$	Shutdown Pin Active-Low
6	V <sub>DD</sub>	Power Supply Input

### 1.1 Buffered V<sub>REF</sub> Output (OUT)

This is the buffered reference output. The output driver is tri-stated when in shutdown.

### 1.2 System Ground (GND)

This is the power supply return and should be connected to system ground.

### 1.3 Shutdown Pin ( $\overline{\text{SHDN}}$ )

This is a digital input that will place the device in shutdown. The device should be allowed to power up before using this feature. This pin is active-low. When this pin is low, there will be no output.

**Note:** Before using the Shutdown pin, the device should first be powered up. Once the device is fully powered up, the Shutdown pin can be used.

### 1.4 Power Supply Input (V<sub>DD</sub>)

This power pin also serves as the input voltage for the voltage reference. Refer to [Section 2.0 “Electrical Characteristics”](#) to determine minimum voltage based on the device. It is recommended to connect a 0.1  $\mu\text{F}$  capacitor very close to the V<sub>DD</sub> pin.

# MCP1502

---

NOTES:

## 2.0 ELECTRICAL CHARACTERISTICS

### Absolute Maximum Ratings<sup>(†)</sup>

$V_{DD}$ .....	5.5V
Maximum current into $V_{DD}$ pin.....	30 mA
Clamp current, $I_K$ ( $V_{PIN} < 0$ or $V_{PIN} > V_{DD}$ ).....	$\pm 20$ mA
Maximum output current sunk by OUT pin.....	30 mA
Maximum output current sourced by OUT pin.....	30 mA
(HBM:CDM:MM).....	(2 kV: $\pm 1.5$ kV:200V)

† **Notice:** Stresses above those listed under “Absolute Maximum Ratings” may cause permanent damage to the device. This is a stress rating only and functional operation of the device at those or any other conditions above those indicated in the operation listings of this specification is not implied. Exposure above maximum rating conditions for extended periods may affect device reliability.

**TABLE 2-1: DC CHARACTERISTICS**

Electrical Characteristics: Unless otherwise specified, $V_{DD(MIN)} \leq V_{DD} \leq 5.5V$ at $-40^{\circ}C \leq T_A \leq +125^{\circ}C$ .							
Characteristic	Sym.	Min.	Typ.	Max.	Units	Conditions	
Supply Voltage	$V_{DD}$	1.65	—	5.5	V	MCP1502-10	
	$V_{DD}$	1.65	—	5.5	V	MCP1502-12	
	$V_{DD}$	2.0	—	5.5	V	MCP1502-18	
	$V_{DD}$	2.25	—	5.5	V	MCP1502-20	
	$V_{DD}$	2.70	—	5.5	V	MCP1502-25	
	$V_{DD}$	3.2	—	5.5	V	MCP1502-30	
	$V_{DD}$	3.5	—	5.5	V	MCP1502-33	
	$V_{DD}$	4.3	—	5.5	V	MCP1502-40	
Power-on Reset Release Voltage ( <b>Note 1</b> )	$V_{POR}$	—	1.45	—	V		
Power-on Reset Rearm Voltage ( <b>Note 2</b> )	—	—	0.8	—	V		
Output Voltage	MCP1502-10	$V_{OUT}$	1.0230	1.0240	1.0250	V	Temperature @ +25°C
	MCP1502-12		1.2488	1.2500	1.2513	V	
	MCP1502-18		1.7982	1.800	1.8018	V	
	MCP1502-20		2.0460	2.0480	2.0500	V	
	MCP1502-25		2.4975	2.500	2.5025	V	
	MCP1502-30		2.9970	3.000	3.0030	V	
	MCP1502-33		3.2967	3.300	3.3033	V	
	MCP1502-40		4.0919	4.0960	4.1001	V	
Temperature Coefficient	MCP1502-XX	$T_C$	—	5	7	ppm/°C	
Line Regulation	$\Delta V_{OUT}/\Delta V_{IN}$	—	5	50	ppm/V		
Load Regulation	$\Delta V_{OUT}/\Delta I_{OUT}$	—	5 ppm – sink	40 ppm – sink	ppm/mA	-5 mA < $I_{LOAD}$	

- Note 1:** On rising  $V_{DD}$ , the voltage at which the device internal Reset will get released.
- 2:** On dropping  $V_{DD}$ , the voltage at which the internal Reset circuit will reset. On dropping  $V_{DD}$ , it is recommended to bring the  $V_{DD}$  below this voltage to get a proper Reset.
- 3:** Before using the  $\overline{SHDN}$  pin, the device should first be powered up. Once the device is fully powered up, then the Shutdown pin can be used.
- 4:**  $\mu V_{PP}$  is six times the value of  $\mu V_{RMS}$ .

# MCP1502

**TABLE 2-1: DC CHARACTERISTICS (CONTINUED)**

<b>Electrical Characteristics:</b> Unless otherwise specified, $V_{DD(MIN)} \leq V_{DD} \leq 5.5V$ at $-40^{\circ}C \leq T_A \leq +125^{\circ}C$ .							
Characteristic	Sym.	Min.	Typ.	Max.	Units	Conditions	
Load Regulation	$\Delta V_{OUT}/\Delta I_{OUT}$	—	5 ppm – source	70 ppm – source	ppm/mA	$I_{LOAD} < +5$ mA	
Dropout Voltage	$V_{DO}$	—	—	200	mV	$-5$ mA $< I_{LOAD} < +5$ mA	
Power Supply Rejection Ratio	PSRR	—	94	—	dB	All device options, $V_{IN} = 5.5V$ , 60 Hz at 100 mV <sub>P,P</sub>	
Shutdown (Note 3)	$V_{IL}$	—	1.35	—	V	$V_{IN} = 5V$ , refer to Section 1.3 “Shutdown Pin (SHDN)”	
	$V_{IH}$	—	3.80	—	V		
Output Voltage Hysteresis	$\Delta V_{OUT\_HYST}$	—	300 $\mu$ V	—		Refer to Section 2.1.9 “Output Voltage Hysteresis” for additional details on testing conditions	
Output Noise	MCP1502-10	$e_N$	—	18	—	$\mu$ V <sub>PP</sub>	0.1 Hz to 10 Hz, $T_A = +25^{\circ}C$
			—	30	—	$\mu$ V <sub>RMS</sub>	10 Hz to 10 kHz, $T_A = +25^{\circ}C$
	MCP1502-40	$e_N$	—	57	—	$\mu$ V <sub>PP</sub>	0.1 Hz to 10 Hz, $T_A = +25^{\circ}C$
			—	97	—	$\mu$ V <sub>RMS</sub>	10 Hz to 10 kHz, $T_A = +25^{\circ}C$
Maximum Load Current	$I_{LOAD}$	—	$\pm 20$	—	mA	$T_A = +25^{\circ}C$ , all device options	
Supply Current	$I_{DD}$	—	140	550	$\mu$ A	No load	
		—	—	350		No load, $T_A = +25^{\circ}C$	
Shutdown Current	$I_{SHDN}$	—	205	—	nA	$T_A = +25^{\circ}C$ , all device options	

- Note 1:** On rising  $V_{DD}$ , the voltage at which the device internal Reset will get released.
- 2:** On dropping  $V_{DD}$ , the voltage at which the internal Reset circuit will reset. On dropping  $V_{DD}$ , it is recommended to bring the  $V_{DD}$  below this voltage to get a proper Reset.
- 3:** Before using the  $\overline{SHDN}$  pin, the device should first be powered up. Once the device is fully powered up, then the Shutdown pin can be used.
- 4:**  $\mu$ V<sub>PP</sub> is six times the value of  $\mu$ V<sub>RMS</sub>.

**TABLE 2-2: TEMPERATURE SPECIFICATIONS**

<b>Electrical Specifications:</b> Unless otherwise indicated, all parameters apply at $V_{DD} = V_{DD(MIN)}$ to 5.5V.						
Parameters	Sym.	Min.	Typ.	Max.	Units	Conditions
<b>Temperature Ranges</b>						
Operating Temperature Range	$T_A$	-40	—	+125	$^{\circ}C$	
Storage Temperature Range	$T_A$	-65	—	+150	$^{\circ}C$	
<b>Thermal Package Resistance</b>						
Thermal Resistance for 6-Lead SOT-23	$\theta_{JA}$	—	+190.5	—	$^{\circ}C/W$	

## 2.1 Terminology

### 2.1.1 OUTPUT VOLTAGE ( $V_{OUT}$ )

Output Voltage ( $V_{OUT}$ ) is the reference voltage that is available on the OUT pin.

### 2.1.2 INPUT VOLTAGE ( $V_{IN}$ )

The Input Voltage ( $V_{IN}$ ) is the range of voltage that can be applied to the  $V_{DD}$  pin and still have the device produce the designated output voltage on the OUT pin.

### 2.1.3 TEMPERATURE COEFFICIENT ( $T_C$ )

The output Temperature Coefficient ( $T_C$ ) or voltage drift is a measure of how much the output voltage will vary from its initial value with changes in ambient temperature. The value specified in the electrical specifications is measured as shown in [Equation 2-1](#).

#### EQUATION 2-1: $T_C$ CALCULATION

$$T_C = \frac{V_{OUT(MAX)} - V_{OUT(MIN)}}{\Delta T \times V_{OUT(NOM)}} \times 10^6 \text{ ppm}/^\circ\text{C}$$

Where:

- $V_{OUT(MAX)}$  = Maximum output voltage over the temperature range
- $V_{OUT(MIN)}$  = Minimum output voltage over the temperature range
- $V_{OUT(NOM)}$  = Average output voltage over the temperature range
- $\Delta T$  = Temperature range over which the data were collected

### 2.1.4 DROPOUT VOLTAGE ( $V_{DO}$ )

The Dropout Voltage ( $V_{DO}$ ) is defined as the voltage difference between  $V_{DD}$  and  $V_{OUT}$  under a 5 mA load, where  $V_{OUT}$  is reduced by 1% from the nominal value.

### 2.1.5 LINE REGULATION

An ideal voltage reference will maintain a constant output voltage, regardless of any changes to the input voltage. However, when real devices are considered, a small error may be measured on the output when an input voltage change occurs.

Line regulation is defined as the change in Output Voltage ( $\Delta V_{OUT}$ ) as a function of a change in the Input Voltage ( $\Delta V_{IN}$ ), and expressed as a percentage, as shown in [Equation 2-2](#).

#### EQUATION 2-2:

$$\frac{\Delta V_{OUT}}{\Delta V_{IN}} \times 100\% = \% \text{ Line Regulation}$$

Line regulation may also be expressed as %/V or in ppm/V, as shown in [Equation 2-3](#) and [Equation 2-4](#), respectively.

#### EQUATION 2-3:

$$\left( \frac{\Delta V_{OUT}}{V_{OUT(NOM)}} \right) \times 100\% = \frac{\%}{V} \text{ Line Regulation}$$

#### EQUATION 2-4:

$$\left( \frac{\Delta V_{OUT}}{V_{OUT(NOM)}} \right) \times 10^6 = \frac{\text{ppm}}{V} \text{ Line Regulation}$$

As an example, if the MCP1502-20 is implemented in a design and a 2  $\mu\text{V}$  change in output voltage is measured from a 250 mV change on the input, then the error in percent and ppm/volt will be as shown in [Equation 2-5](#) and [Equation 2-6](#).

#### EQUATION 2-5:

$$\left( \frac{\Delta V_{OUT}}{\Delta V_{IN}} \times 100\% \right) \times \left( \frac{2 \mu\text{V}}{250 \text{ mV}} \times 100\% \right) = .0008\%$$

#### EQUATION 2-6:

$$\frac{\Delta V_{OUT}}{\Delta V_{IN}} \times 10^6 = \left( \frac{2 \mu\text{V}}{250 \text{ mV}} \right) \times 10^6 = 3.90625 \frac{\text{ppm}}{V}$$

# MCP1502

## 2.1.6 LOAD REGULATION

An ideal voltage reference will maintain the specified output voltage regardless of the load's current demand. However, real devices experience a small error voltage that deviates from the specified output voltage when a load is present.

### EQUATION 2-7:

$$\frac{V_{OUT @ I_{OUT|0}} - V_{OUT @ I_{OUT|MAX}}}{V_{OUT @ I_{OUT|0}}} \times 100\% = \% \text{ Load Regulation}$$

Similar to line regulation, load regulation may also be expressed as %/mA or in ppm/mA, as shown in Equation 2-8 and Equation 2-9, respectively.

### EQUATION 2-8:

$$\left( \frac{\Delta V_{OUT}}{V_{OUT(NOM)}} \right) \times 100\% = \frac{\%}{mA} \text{ Load Regulation}$$

### EQUATION 2-9:

$$\left( \frac{\Delta V_{OUT}}{V_{OUT(NOM)}} \right) \times 10^6 = \frac{ppm}{mA} \text{ Load Regulation}$$

As an example, if the MCP1502-20 is implemented in a design and a 10  $\mu$ V change in output voltage is measured from a 2 mA change in the output load, then the error in percent, ppm/mA, is as shown in Equation 2-10 and Equation 2-11.

### EQUATION 2-10:

$$\frac{2.048V - 2.04799V}{2.04799V} \times 100\% = .0004882\%$$

### EQUATION 2-11:

$$\left( \frac{\Delta V_{OUT}}{V_{OUT(NOM)}} \right) \times 10^6 = \left( \frac{10 \mu V}{2 mA} \right) \times 10^6 = 2.441 \frac{ppm}{mA}$$

## 2.1.7 POWER SUPPLY REJECTION RATIO (PSRR)

Power Supply Rejection Ratio (PSRR) is a measure of the change in Output Voltage ( $\Delta V_{OUT}$ ) relative to the change in Input Voltage ( $\Delta V_{IN}$ ) over frequency.

Load regulation is defined as the voltage difference when under no load ( $V_{OUT @ I_{OUT|0}}$ ) and under maximum load ( $V_{OUT @ I_{OUT|MAX}}$ ), and is expressed as a percentage, as shown in Equation 2-7.

## 2.1.8 LONG-TERM DRIFT

The long-term output stability is measured by exposing the devices to an ambient temperature of +25°C.

## 2.1.9 OUTPUT VOLTAGE HYSTERESIS

The output voltage hysteresis is a measure of the output voltage error after the powered devices are cycled over the entire operating temperature range. The amount of hysteresis can be quantified by measuring the change in the +25°C output voltage after temperature excursions from +25°C to +125°C to +25°C, and also from +25°C to -40°C to +25°C.

## 2.1.10 LAYOUT CONSIDERATION FOR LOAD REGULATION

For applications which require high currents and/or highly variable currents, the PCB layout is important for minimizing the load coefficient (variation in output voltage vs. load current) of the device. Of particular importance is the grounding of the device to a large ground plane with good thermal mass. The MCP1502 should not be placed on a small daughter card, or connected to ground via long traces or single vias if the load coefficient is to be optimized; the additional power dissipation caused by the high load current will cause a small change in the output voltage due to self-heating of the device.

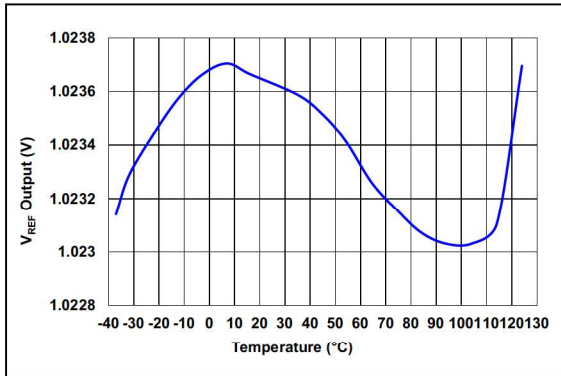
For systems with high ground currents, variations in the local ground can also be a source of the load coefficient. These are usually solved by ensuring the local ground for the device is shared with the Point-of-Load (POL). In some cases, it may be necessary to ensure the device ground is specifically Kelvin sourced from the Point-of-Load, such that a zero IR drop from unassociated circuitry is seen on the device output voltage.



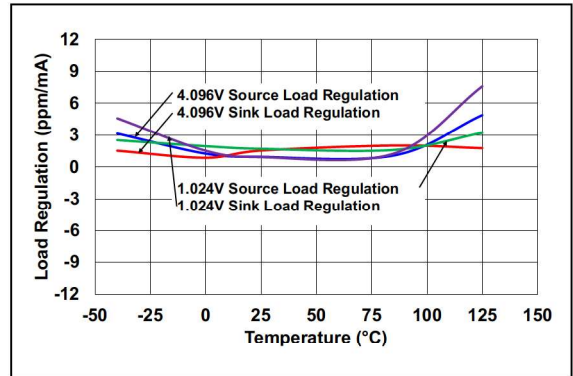
## 3.0 TYPICAL OPERATING CURVES

**Note:** The graphs and tables provided following this note are a statistical summary based on a limited number of samples and are provided for informational purposes only. The performance characteristics listed herein are not tested or guaranteed. In some graphs or tables, the data presented may be outside the specified operating range (e.g., outside specified power supply range) and therefore outside the warranted range.

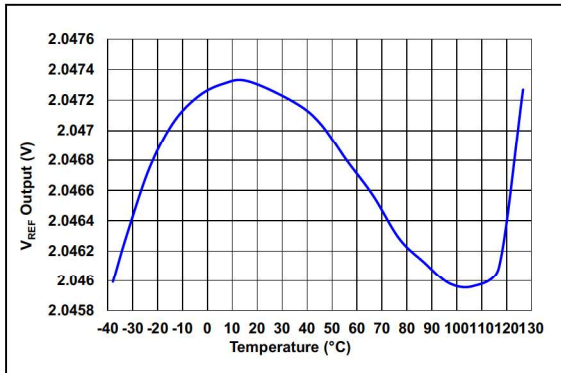
**Note:** Unless otherwise specified, maximum values are:  $V_{DD(MIN)} \leq V_{DD} \leq 5.5V$  at  $T_A = +25^\circ C$ .



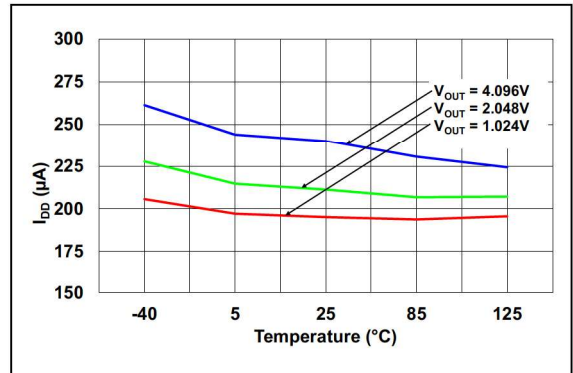
**FIGURE 3-1:** MCP1502-10  $V_{REF}$  Output vs. Temperature,  $V_{DD} = 5.5V$ .



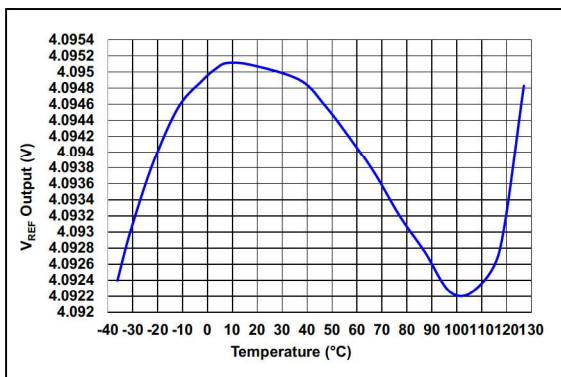
**FIGURE 3-4:** Load Regulation vs. Temperature.



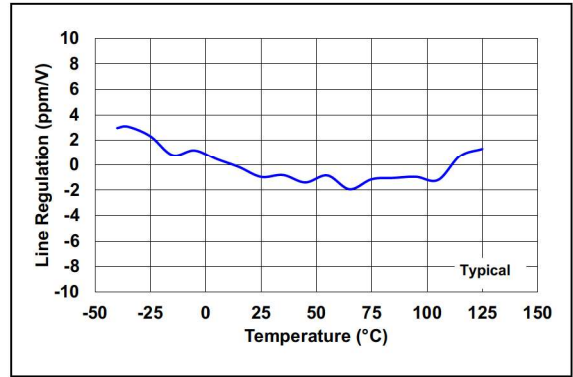
**FIGURE 3-2:** MCP1502-20  $V_{REF}$  Output vs. Temperature,  $V_{DD} = 5.5V$ .



**FIGURE 3-5:**  $I_{DD}$  vs. Temperature.



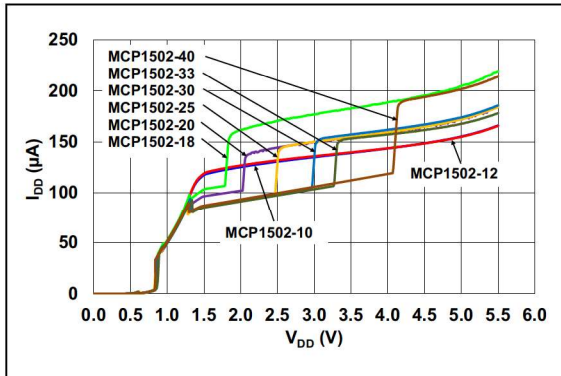
**FIGURE 3-3:** MCP1502-40  $V_{REF}$  Output vs. Temperature,  $V_{DD} = 5.5V$ .



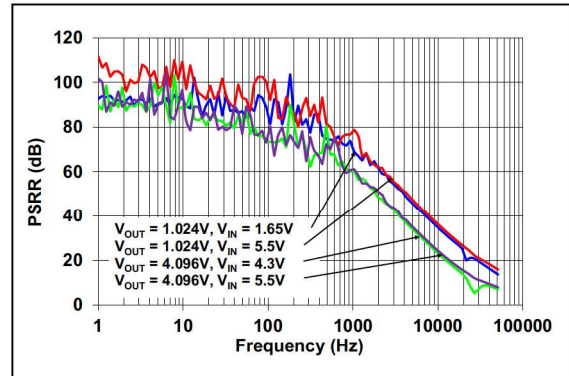
**FIGURE 3-6:** MCP1502 – Line Regulation vs. Temperature.

# MCP1502

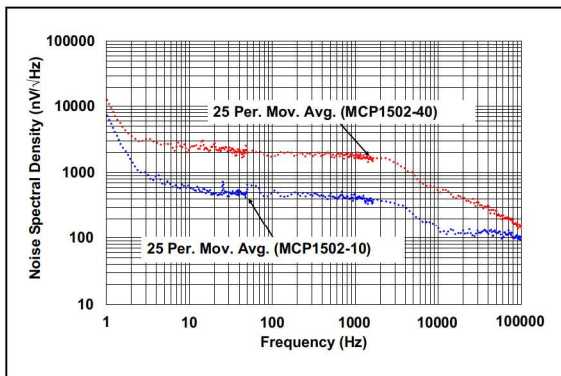
**Note:** Unless otherwise specified, maximum values are:  $V_{DD(MIN)} \leq V_{DD} \leq 5.5V$  at  $T_A = +25^\circ C$ .



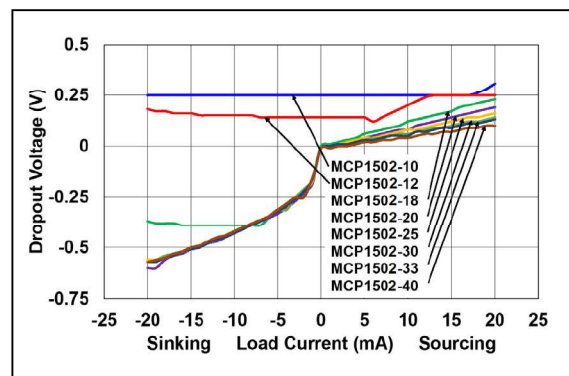
**FIGURE 3-7:**  $I_{DD}$  vs.  $V_{DD}$  for All Options.



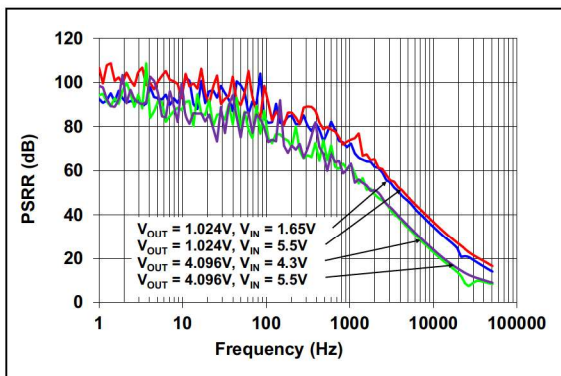
**FIGURE 3-10:** PSRR vs. Frequency, 1 kΩ Load,  $T_A = +25^\circ C$ .



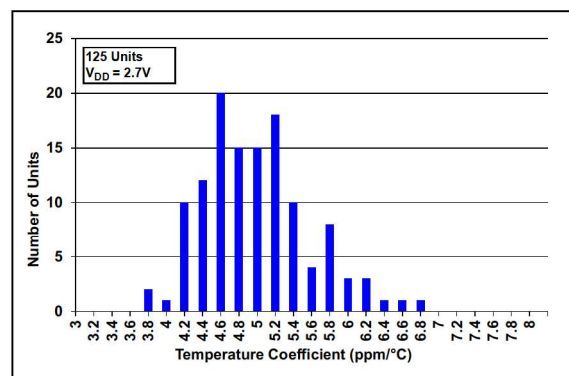
**FIGURE 3-8:** Noise vs. Frequency, No Load,  $T_A = +25^\circ C$ .



**FIGURE 3-11:** Dropout Voltage vs. Load,  $T_A = +25^\circ C$ .

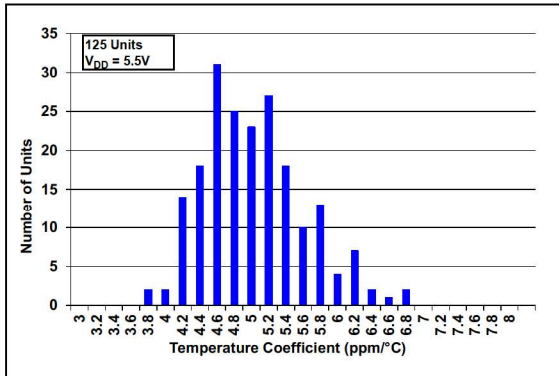


**FIGURE 3-9:** PSRR vs. Frequency, No Load,  $T_A = +25^\circ C$ .

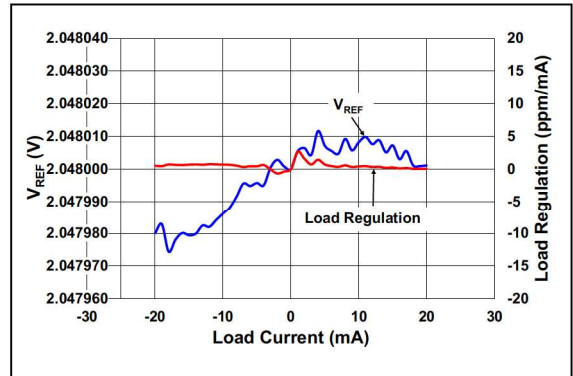


**FIGURE 3-12:** MCP1502 Tempco Distribution, No Load,  $V_{DD} = 2.7V$ .

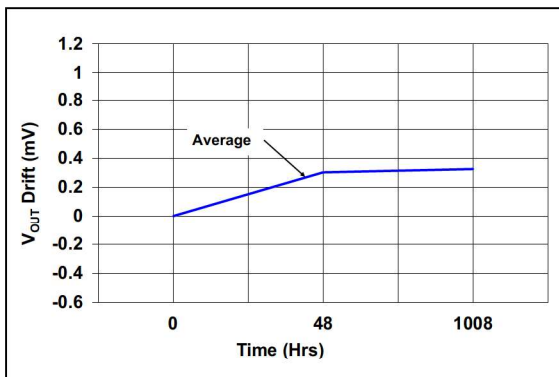
**Note:** Unless otherwise specified, maximum values are:  $V_{DD(MIN)} \leq V_{DD} \leq 5.5V$  at  $T_A = +25^\circ C$ .



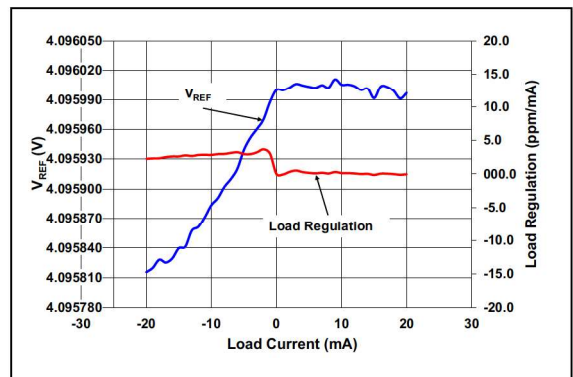
**FIGURE 3-13:** MCP1502 Tempco Distribution, No Load,  $V_{DD} = 5.5V$ .



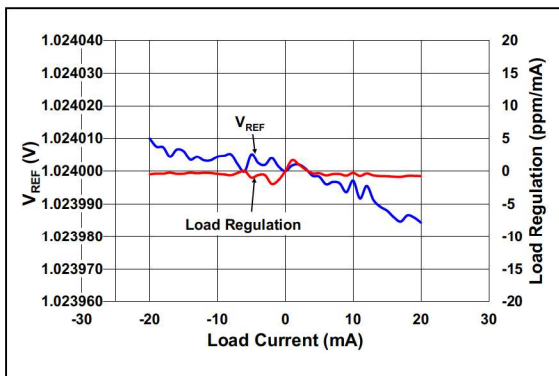
**FIGURE 3-16:** MCP1502-20  $V_{REF}$  and Load Regulation vs. Load Current.



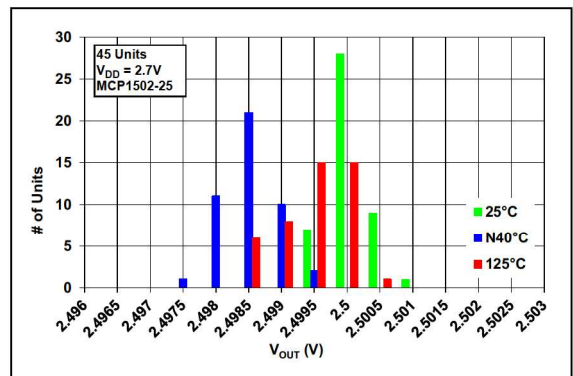
**FIGURE 3-14:**  $V_{OUT}$  Drift vs. Time,  $T_A = +25^\circ C$ , No Load, 800 Units.



**FIGURE 3-17:** MCP1502-40  $V_{REF}$  and Load Regulation vs. Load Current.



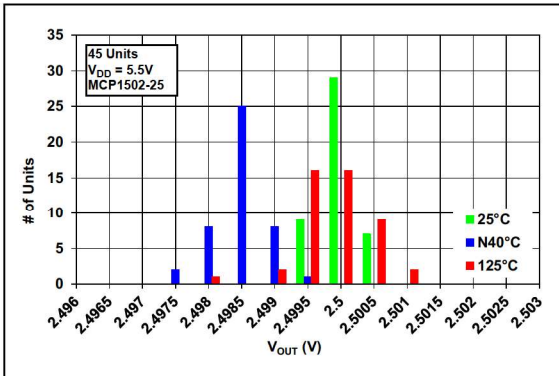
**FIGURE 3-15:** MCP1502-10  $V_{REF}$  and Load Regulation vs. Load Current.



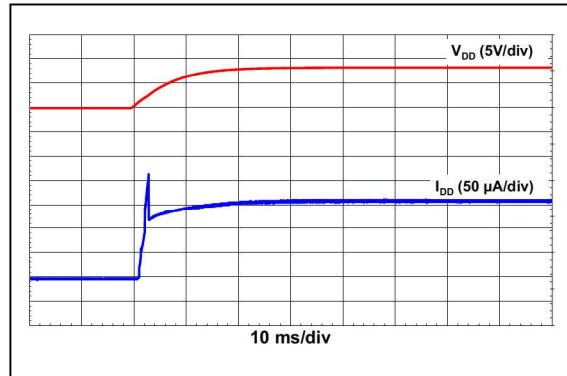
**FIGURE 3-18:** MCP1502 Output Voltage Histogram,  $V_{DD} = 2.7V$ .

# MCP1502

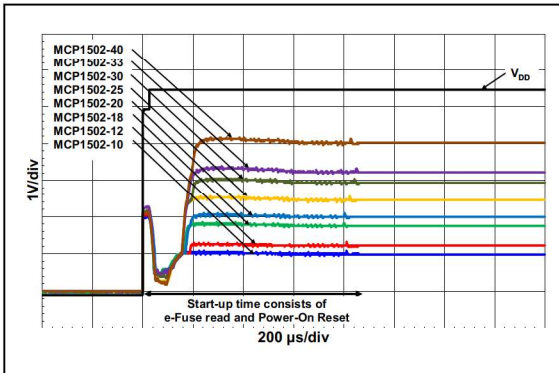
**Note:** Unless otherwise specified, maximum values are:  $V_{DD(MIN)} \leq V_{DD} \leq 5.5V$  at  $T_A = +25^\circ C$ .



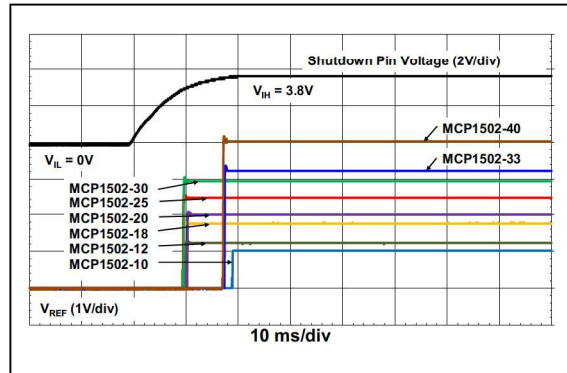
**FIGURE 3-19:** MCP1502 Output Voltage Histogram,  $V_{DD} = 5.5V$ .



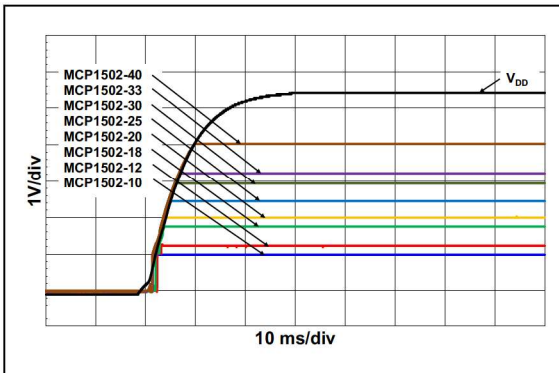
**FIGURE 3-22:**  $I_{DD}$  Turn-On Transient Response.



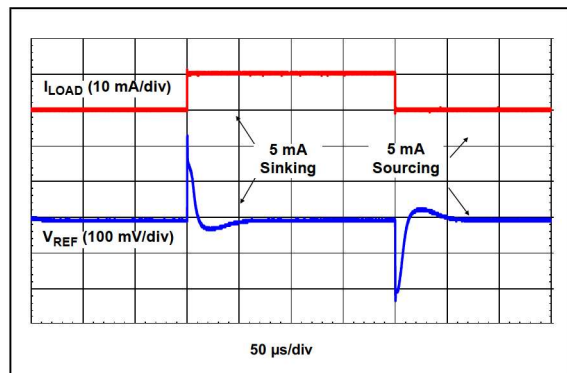
**FIGURE 3-20:** Fast Ramp Start-up @  $+25^\circ C$  for All Options.



**FIGURE 3-23:** Shutdown Low-to-High Slow Ramp Turn-On Transient Response @  $+25^\circ C$  for All Options.

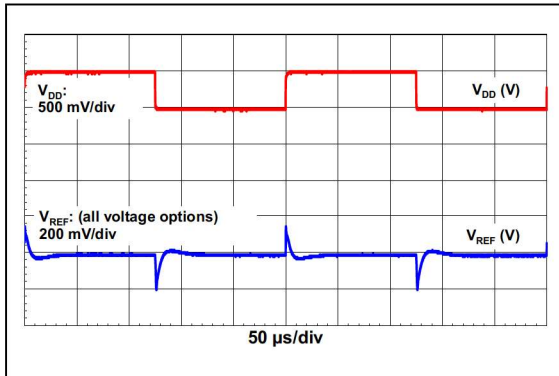


**FIGURE 3-21:** Slow Ramp Start-up @  $+25^\circ C$  for All Options.

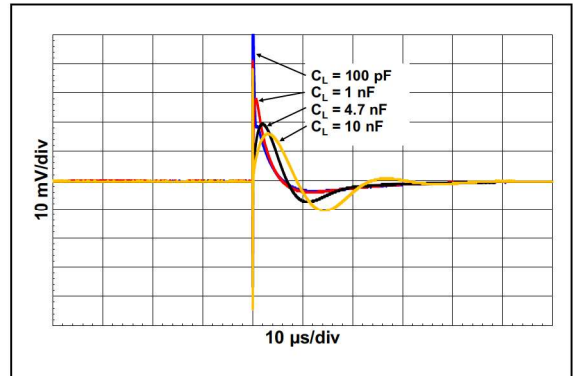


**FIGURE 3-24:** Load Regulation Transient Response @  $+25^\circ C$  for All Options.

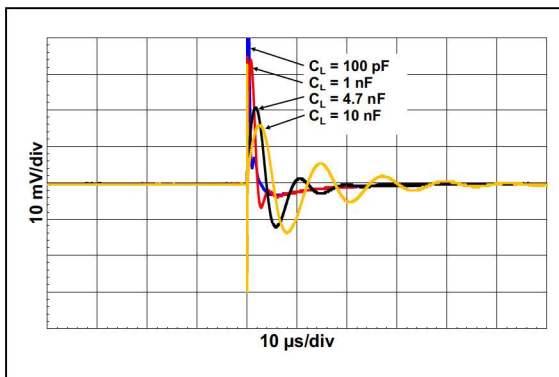
**Note:** Unless otherwise specified, maximum values are:  $V_{DD(MIN)} \leq V_{DD} \leq 5.5V$  at  $T_A = +25^\circ C$ .



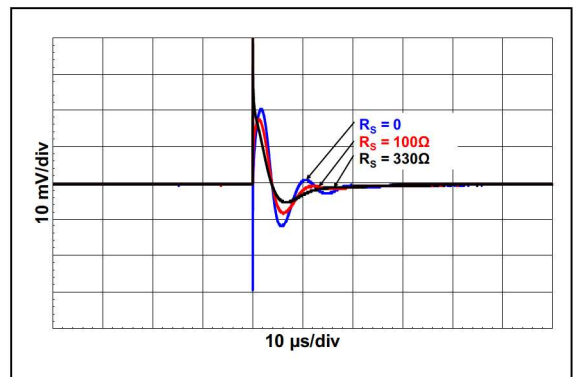
**FIGURE 3-25:** Line Regulation Transient Response @  $+25^\circ C$  for All Options.



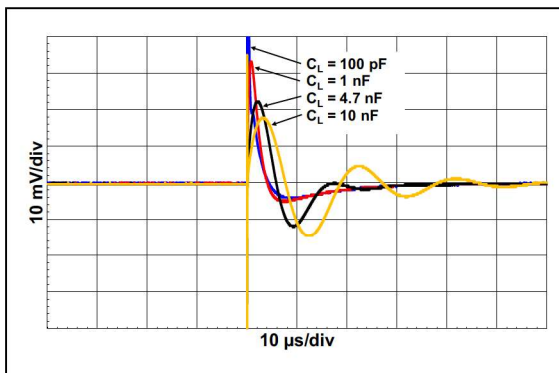
**FIGURE 3-28:** MCP1502-40 Transient Response vs. Capacitive Load,  $V_{DD} = 5V$ .



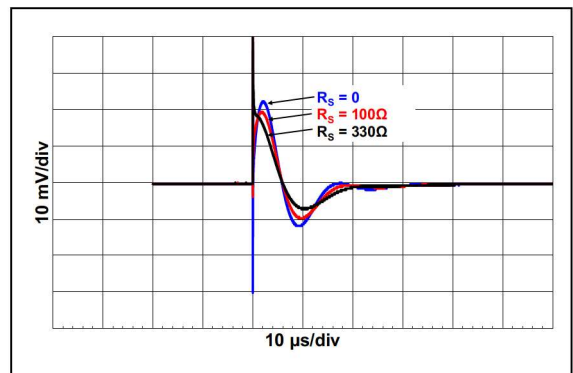
**FIGURE 3-26:** MCP1502-10 Transient Response vs. Capacitive Load,  $V_{DD} = 5V$ .



**FIGURE 3-29:** MCP1502-10 Transient Response vs.  $R_S$ ,  $V_{DD} = 5V$ ,  $C_L = 4.7 nF$ .



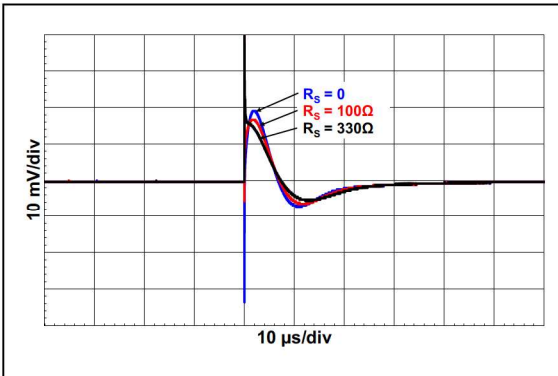
**FIGURE 3-27:** MCP1502-20 Transient Response vs. Capacitive Load,  $V_{DD} = 5V$ .



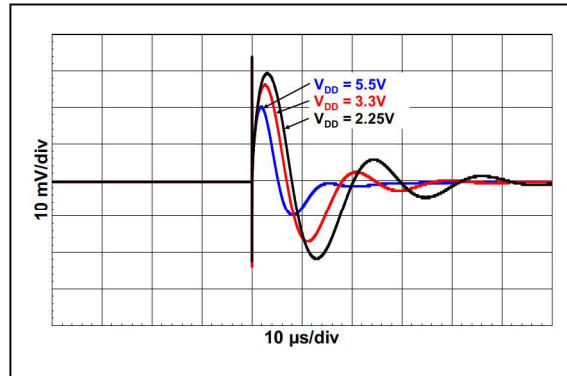
**FIGURE 3-30:** MCP1502-20 Transient Response vs.  $R_S$ ,  $V_{DD} = 5V$ ,  $C_L = 4.7 nF$ .

# MCP1502

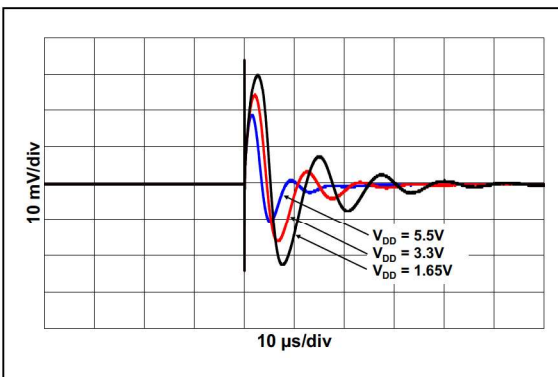
**Note:** Unless otherwise specified, maximum values are:  $V_{DD(MIN)} \leq V_{DD} \leq 5.5V$  at  $T_A = +25^\circ C$ .



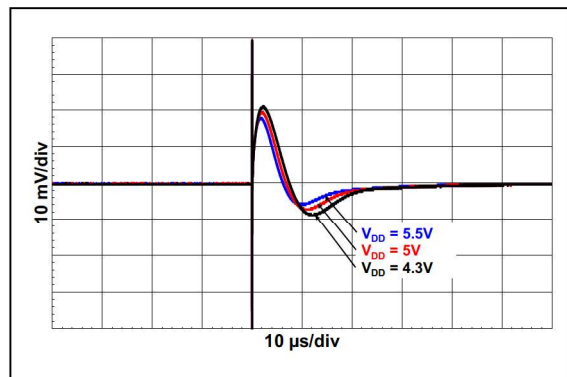
**FIGURE 3-31:** MCP1502-40 Transient Response vs.  $R_S$ ,  $V_{DD} = 5V$ ,  $C_L = 4.7 nF$ .



**FIGURE 3-33:** MCP1502-20 Transient Response vs.  $V_{DD}$ ,  $C_L = 4.7 nF$ .



**FIGURE 3-32:** MCP1502-10 Transient Response vs.  $V_{DD}$ ,  $C_L = 4.7 nF$ .



**FIGURE 3-34:** MCP1502-40 Transient Response vs.  $V_{DD}$ ,  $C_L = 4.7 nF$ .

## 4.0 THEORY OF OPERATION

The MCP1502 is a buffered voltage reference that is capable of operating over a wide input supply range, while providing a stable output across the input supply range. Refer to the [Block Diagram](#) for the details of the MCP1502. As with all band gap circuits, the internal reference sums together two voltages having an opposite temperature coefficient, which allows a voltage reference that is practically independent from temperature.

MCP1502 band gap is based on a second-order temperature compensated circuit. This allows the MCP1502 to achieve high initial accuracy and low-temperature coefficient operation across voltage and temperature. The band gap curvature compensation is determined during device characterization and is trimmed for optimal accuracy.

The MCP1502 also includes a chopper-based amplifier architecture that ensures excellent low noise operation, which further reduces temperature-dependent offsets that would otherwise increase the temperature coefficient of the MCP1502, and significantly improves long-term drift performance. Additional circuitry is included to eliminate the chopping frequency from the output of the device.

After the band gap voltage is compensated, it is attenuated, buffered and provided to the output drive circuit. The device has excellent performance when sinking or sourcing load currents ( $\pm 20$  mA).

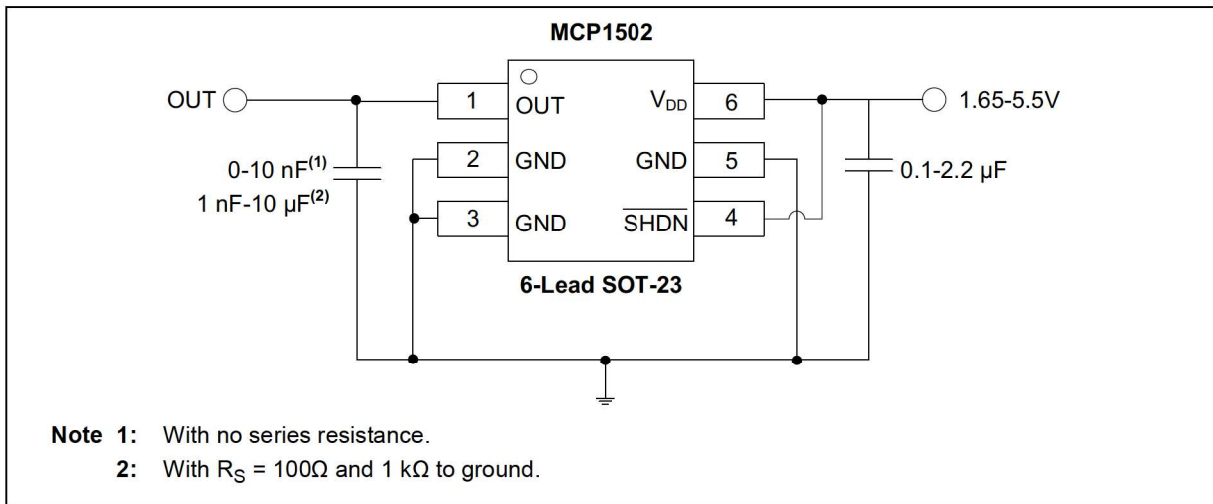
# MCP1502

## 5.0 APPLICATION CIRCUITS

### 5.1 Application Tips

#### 5.1.1 BASIC APPLICATION CIRCUIT

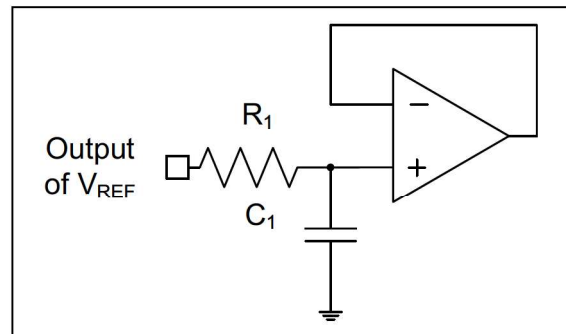
Figure 5-1 illustrates a basic circuit configuration of the MCP1502.



**FIGURE 5-1:** Basic Circuit Configuration.

An output capacitor is not required for stability of the voltage reference, but may be optionally added to provide noise filtering or act as a charge reservoir for switching loads (e.g., Successive Approximation Register (SAR) Analog-to-Digital Converter (ADC)). As shown in Figure 5-5, the input voltage is connected to the device at the  $V_{DD}$  input, with an optional 2.2  $\mu\text{F}$  ceramic capacitor. This capacitor would be required if the input voltage has excessive noise. A 2.2  $\mu\text{F}$  capacitor would reject input voltage noise at approximately 1 to 2 MHz. Noise below this frequency will be amply rejected by the input voltage rejection of the voltage reference. Noise at frequencies above 2 MHz will be beyond the bandwidth of the voltage reference, and consequently, not transmitted from the input pin through the device to the output.

If the noise at the output of the voltage references is too high for the particular application, it can be easily filtered with an external RC filter and op amp buffer (see Figure 5-2).



**FIGURE 5-2:** Output Noise Reducing Filter.

The RC filter values are selected for a desired cutoff frequency, as shown in Equation 5-1.

#### EQUATION 5-1:

$$f_C = \frac{1}{2\pi(RI \times CI)}$$

The values that are shown in Figure 5-5 (1 k $\Omega$  and 10  $\mu\text{F}$ ) will create a first-order, low-pass filter at the output of the amplifier. The cutoff frequency of this filter is 15.9 Hz, and the attenuation slope is 20 dB/decade. The MCP6286 amplifier isolates the loading of this low-pass filter from the remainder of the application circuit. This amplifier also provides additional drive with a faster response time than the voltage reference.



## 5.1.2 LOAD CAPACITOR

The maximum capacitive load without series resistance is 10 nF. However, larger capacitors may be implemented if a resistor is used in series with a larger load capacitor. Refer to [Figure 3-29](#), [Figure 3-30](#) and [Figure 3-31](#) for the transient response with the series resistor and capacitive load.

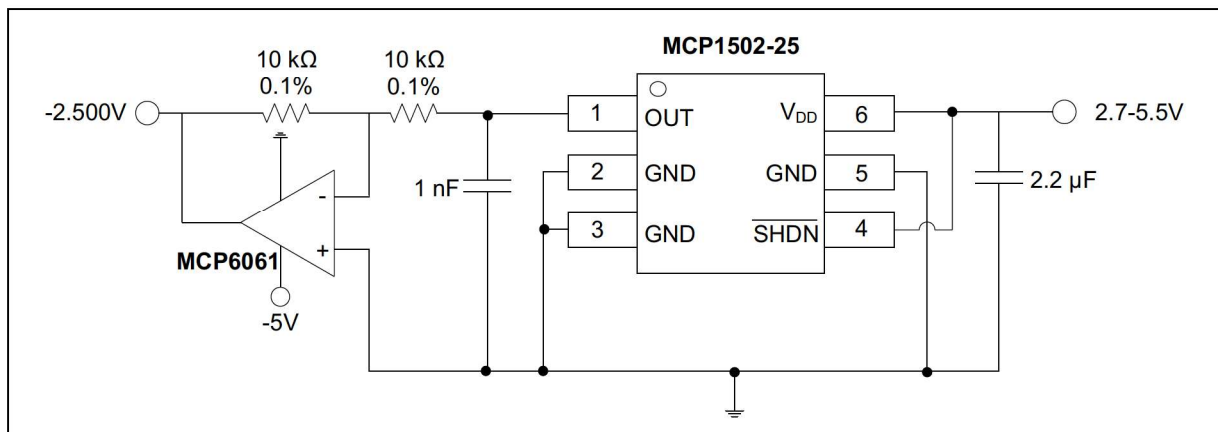
## 5.1.3 PRINTED CIRCUIT BOARD LAYOUT CONSIDERATIONS

Mechanical stress due to Printed Circuit Board (PCB) mounting can cause the output voltage to shift from its initial value. To reduce stress-related output voltage shifts, mount the reference on low stress areas of the PCB (i.e., away from PCB edges, screw holes and large components).

## 5.2 Typical Applications Circuits

### 5.2.1 NEGATIVE VOLTAGE REFERENCE

A negative voltage reference can be generated using any of the devices in the MCP1502 family. A typical application is shown in [Figure 5-3](#). In this circuit, the voltage inversion is implemented using the MCP6061 and two equal resistors. The voltage at the output of the MCP1502 voltage reference drives R1, which is connected to the inverting input of the MCP6061 amplifier. Since the noninverting input of the amplifier is biased to ground, the inverting input will also be close to ground potential. The second 10 kΩ resistor is placed around the feedback loop of the amplifier. Since the inverting input of the amplifier is high-impedance, the current generated through R1 will also flow through R2. As a consequence, the output voltage of the amplifier is equal to -2.5V for the MCP1502-25 and -4.096V for the MCP1502-40.



**FIGURE 5-3:** Negative Voltage Reference.

# MCP1502

## 5.2.2 A/D CONVERTER REFERENCE

The MCP1502 product family was carefully designed to provide a precision, low noise voltage reference for the Microchip families of ADCs. The circuit shown in Figure 5-4 shows a MCP1502-25 configured to provide the reference to the MCP3201, a 12-bit ADC.

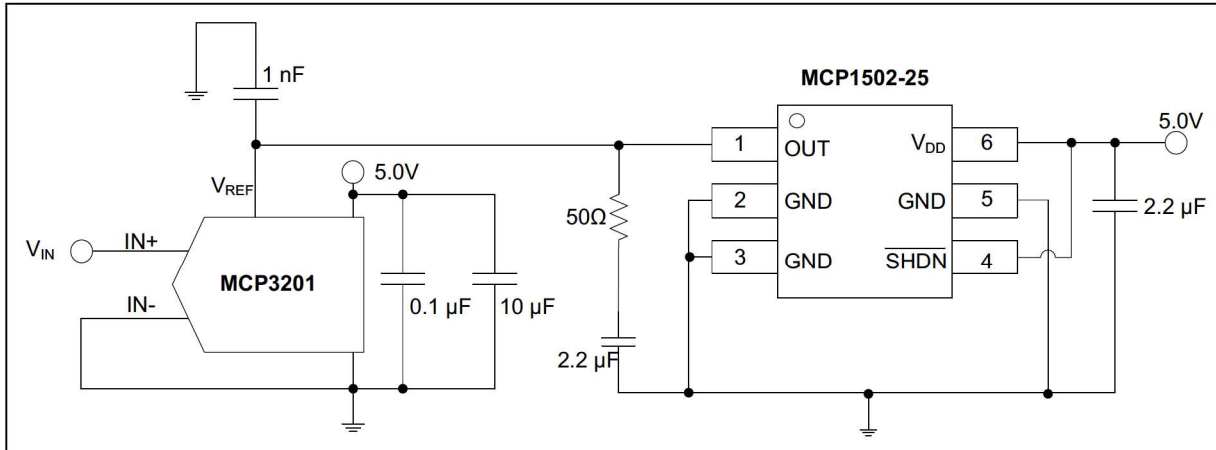


FIGURE 5-4: ADC Example Circuit.

The circuit shown in Figure 5-5 shows a MCP1502-40 configured to provide the reference to a SAR ADC. Refer to the “MCP331X1 16/15/12-Bit Msp/s SAR ADC Evaluation Kit User’s Guide”.

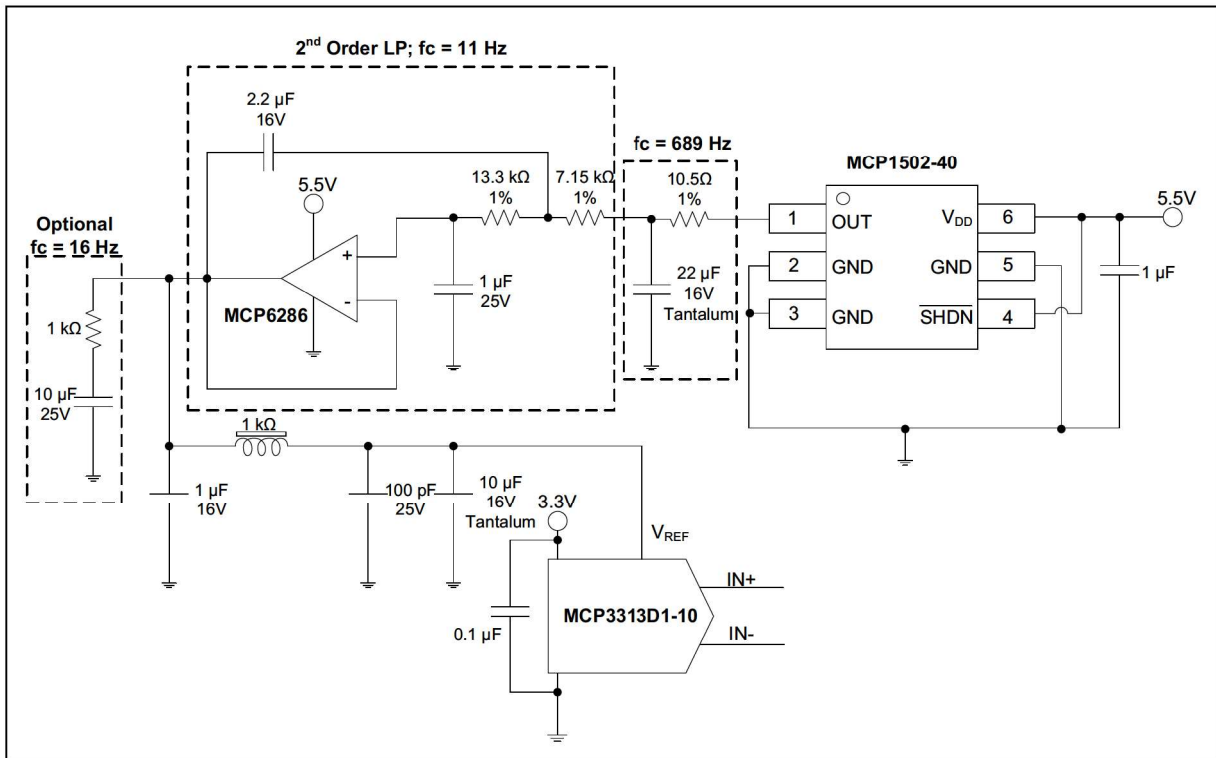
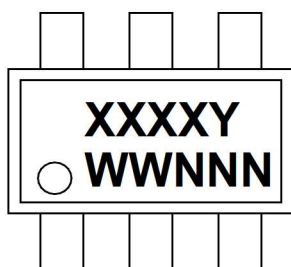


FIGURE 5-5: SAR ADC Example Circuit.

## 6.0 PACKAGE INFORMATION

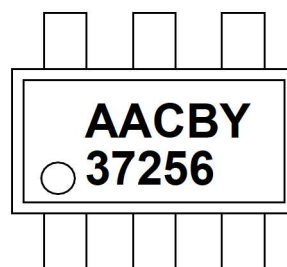
### 6.1 Package Markings

6-Lead SOT-23



Device	Code
MCP1502T-10E/CHY	AACBY
MCP1502T-12E/CHY	AACCY
MCP1502T-18E/CHY	AACDY
MCP1502T-20E/CHY	AACEY
MCP1502T-25E/CHY	AACFY
MCP1502T-30E/CHY	AACGY
MCP1502T-33E/CHY	AACHY
MCP1502T-40E/CHY	AACJY

Example



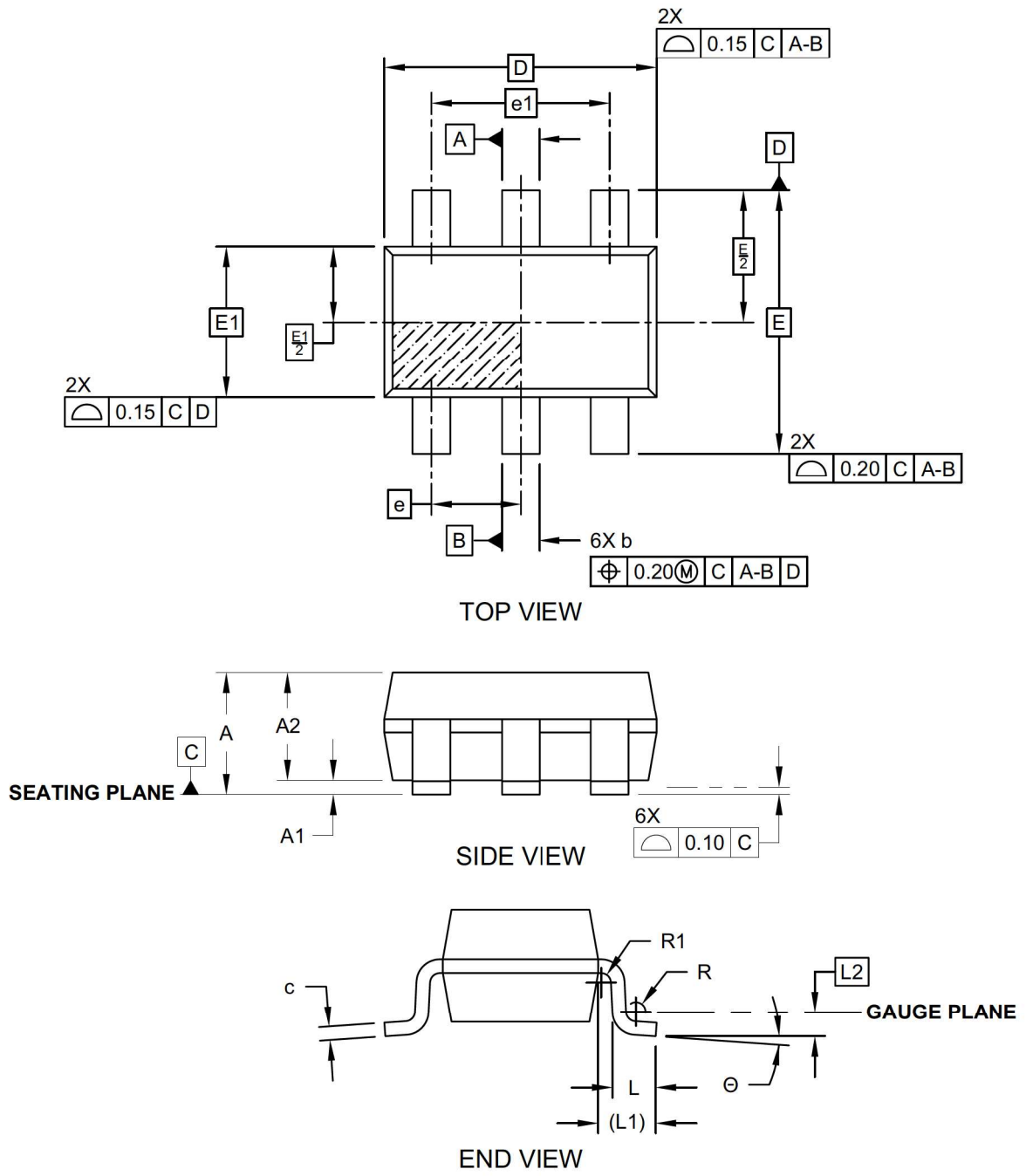
<b>Legend:</b>	XX...X	Customer-specific information
	Y	Year code (last digit of calendar year)
	YY	Year code (last 2 digits of calendar year)
	WW	Week code (week of January 1 is week '01')
	NNN	Alphanumeric traceability code
	(e3)	Pb-free JEDEC® designator for Matte Tin (Sn)
	* (e3)	This package is Pb-free. The Pb-free JEDEC designator (e3) can be found on the outer packaging for this package.

**Note:** In the event the full Microchip part number cannot be marked on one line, it will be carried over to the next line, thus limiting the number of available characters for customer-specific information.

# MCP1502

## 6-Lead Plastic Small Outline Transistor (CH, CHY) [SOT-23]

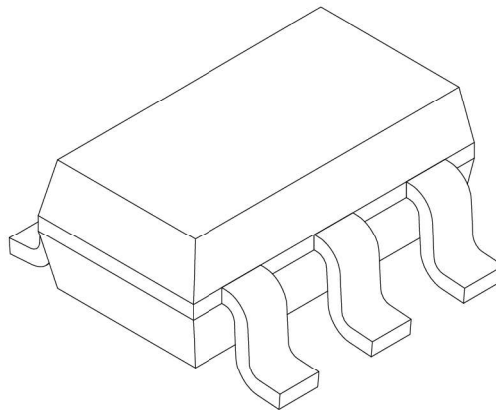
**Note:** For the most current package drawings, please see the Microchip Packaging Specification located at <http://www.microchip.com/packaging>



Microchip Technology Drawing C04-028C (CH) Sheet 1 of 2

## 6-Lead Plastic Small Outline Transistor (CH, CHY) [SOT-23]

**Note:** For the most current package drawings, please see the Microchip Packaging Specification located at <http://www.microchip.com/packaging>



Dimension Limits	Units	MILLIMETERS		
		MIN	NOM	MAX
Number of Leads	N	6		
Pitch	e	0.95 BSC		
Outside lead pitch	e1	1.90 BSC		
Overall Height	A	0.90	-	1.45
Molded Package Thickness	A2	0.89	1.15	1.30
Standoff	A1	0.00	-	0.15
Overall Width	E	2.80 BSC		
Molded Package Width	E1	1.60 BSC		
Overall Length	D	2.90 BSC		
Foot Length	L	0.30	0.45	0.60
Footprint	L1	0.60 REF		
Seating Plane to Gauge Plane	L1	0.25 BSC		
Foot Angle	o	0°	-	10°
Lead Thickness	c	0.08	-	0.26
Lead Width	b	0.20	-	0.51

**Notes:**

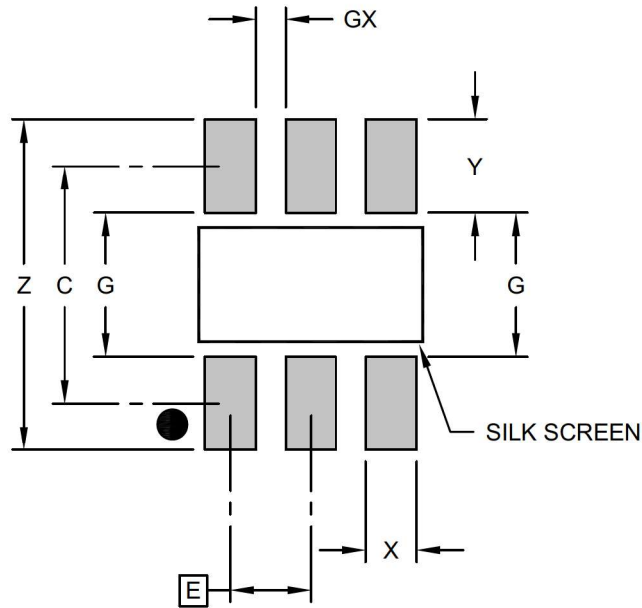
- Dimensions D and E1 do not include mold flash or protrusions. Mold flash or protrusions shall not exceed 0.25mm per side.
- Dimensioning and tolerancing per ASME Y14.5M  
 BSC: Basic Dimension. Theoretically exact value shown without tolerances.  
 REF: Reference Dimension, usually without tolerance, for information purposes only.

Microchip Technology Drawing C04-028C (CH) Sheet 2 of 2

# MCP1502

## 6-Lead Plastic Small Outline Transistor (CH, CHY) [SOT-23]

**Note:** For the most current package drawings, please see the Microchip Packaging Specification located at <http://www.microchip.com/packaging>



RECOMMENDED LAND PATTERN

Dimension Limits	Units	MILLIMETERS		
		MIN	NOM	MAX
Contact Pitch	E	0.95 BSC		
Contact Pad Spacing	C		2.80	
Contact Pad Width (X3)	X			0.60
Contact Pad Length (X3)	Y			1.10
Distance Between Pads	G	1.70		
Distance Between Pads	GX	0.35		
Overall Width	Z			3.90

**Notes:**

1. Dimensioning and tolerancing per ASME Y14.5M

BSC: Basic Dimension. Theoretically exact value shown without tolerances.

Microchip Technology Drawing No. C04-2028B (CH)

## APPENDIX A: REVISION HISTORY

### Revision A (September 2021)

Original Release of this Document.

# MCP1502

---

NOTES:



# MCP1502

## PRODUCT IDENTIFICATION SYSTEM

To order or obtain information, e.g., on pricing or delivery, refer to the factory or the listed sales office.

<u>PART NO.</u>	<u>[X]<sup>(1)</sup></u>	<u>X</u>	<u>/XX</u>
Device	Tape and Reel	Output Voltage Option	Package
<p><b>Device:</b> MCP1502 – 7 ppm maximum thermal drift buffered reference</p> <p><b>Tape and Reel Option:</b> Blank = Standard packaging (tube or tray) T = Tape and Reel<sup>(1)</sup></p> <p><b>Output Voltage Option:</b> 10 = 1.024V 12 = 1.250V 18 = 1.800V 20 = 2.048V 25 = 2.500V 30 = 3.000V 33 = 3.300V 40 = 4.096V</p> <p><b>Package:</b> CHY* = 6-Lead Plastic Small Outline Transistor (SOT-23) *Y = Nickel palladium gold manufacturing designator. Only available on the SOT-23 package.</p>			
<p><b>Examples:</b></p> <p>a) MCP1502T-10E/CHY: 1.024V, 6-Lead SOT-23 Package, Tape and Reel</p> <p><b>Note 1:</b> Tape and Reel identifier only appears in the catalog part number description. This identifier is used for ordering purposes and is not printed on the device package. Check with your Microchip sales office for package availability for the Tape and Reel option.</p>			

# MCP1502

---

NOTES:

---

---

**Note the following details of the code protection feature on Microchip products:**

- Microchip products meet the specifications contained in their particular Microchip Data Sheet.
- Microchip believes that its family of products is secure when used in the intended manner, within operating specifications, and under normal conditions.
- Microchip values and aggressively protects its intellectual property rights. Attempts to breach the code protection features of Microchip product is strictly prohibited and may violate the Digital Millennium Copyright Act.
- Neither Microchip nor any other semiconductor manufacturer can guarantee the security of its code. Code protection does not mean that we are guaranteeing the product is "unbreakable". Code protection is constantly evolving. Microchip is committed to continuously improving the code protection features of our products.

---

This publication and the information herein may be used only with Microchip products, including to design, test, and integrate Microchip products with your application. Use of this information in any other manner violates these terms. Information regarding device applications is provided only for your convenience and may be superseded by updates. It is your responsibility to ensure that your application meets with your specifications. Contact your local Microchip sales office for additional support or, obtain additional support at <https://www.microchip.com/en-us/support/design-help/client-support-services>.

THIS INFORMATION IS PROVIDED BY MICROCHIP "AS IS". MICROCHIP MAKES NO REPRESENTATIONS OR WARRANTIES OF ANY KIND WHETHER EXPRESS OR IMPLIED, WRITTEN OR ORAL, STATUTORY OR OTHERWISE, RELATED TO THE INFORMATION INCLUDING BUT NOT LIMITED TO ANY IMPLIED WARRANTIES OF NON-INFRINGEMENT, MERCHANTABILITY, AND FITNESS FOR A PARTICULAR PURPOSE, OR WARRANTIES RELATED TO ITS CONDITION, QUALITY, OR PERFORMANCE.

IN NO EVENT WILL MICROCHIP BE LIABLE FOR ANY INDIRECT, SPECIAL, PUNITIVE, INCIDENTAL, OR CONSEQUENTIAL LOSS, DAMAGE, COST, OR EXPENSE OF ANY KIND WHATSOEVER RELATED TO THE INFORMATION OR ITS USE, HOWEVER CAUSED, EVEN IF MICROCHIP HAS BEEN ADVISED OF THE POSSIBILITY OR THE DAMAGES ARE FORESEEABLE. TO THE FULLEST EXTENT ALLOWED BY LAW, MICROCHIP'S TOTAL LIABILITY ON ALL CLAIMS IN ANY WAY RELATED TO THE INFORMATION OR ITS USE WILL NOT EXCEED THE AMOUNT OF FEES, IF ANY, THAT YOU HAVE PAID DIRECTLY TO MICROCHIP FOR THE INFORMATION.

Use of Microchip devices in life support and/or safety applications is entirely at the buyer's risk, and the buyer agrees to defend, indemnify and hold harmless Microchip from any and all damages, claims, suits, or expenses resulting from such use. No licenses are conveyed, implicitly or otherwise, under any Microchip intellectual property rights unless otherwise stated.

For information regarding Microchip's Quality Management Systems, please visit [www.microchip.com/quality](http://www.microchip.com/quality).

#### **Trademarks**

The Microchip name and logo, the Microchip logo, Adaptec, AnyRate, AVR, AVR logo, AVR Freaks, BesTime, BitCloud, CryptoMemory, CryptoRF, dsPIC, flexPWR, HELDO, IGL00, JukeBlox, KeeLoq, Klear, LANCheck, LinkMD, maXStylus, maXTouch, MediaLB, megaAVR, Microsemi, Microsemi logo, MOST, MOST logo, MPLAB, OptoLyzer, PIC, picoPower, PICSTART, PIC32 logo, PolarFire, Prochip Designer, QTouch, SAM-BA, SenGenuity, SpyNIC, SST, SST Logo, SuperFlash, Symmetricom, SyncServer, Tachyon, TimeSource, tinyAVR, UNI/O, Vectron, and XMEGA are registered trademarks of Microchip Technology Incorporated in the U.S.A. and other countries.

AgileSwitch, APT, ClockWorks, The Embedded Control Solutions Company, EtherSynch, Flashtec, Hyper Speed Control, HyperLight Load, IntelliMOS, Libero, motorBench, mTouch, Powermite 3, Precision Edge, ProASIC, ProASIC Plus, ProASIC Plus logo, QuietWire, SmartFusion, SyncWorld, Temux, TimeCesium, TimeHub, TimePictra, TimeProvider, TrueTime, WinPath, and ZL are registered trademarks of Microchip Technology Incorporated in the U.S.A.

Adjacent Key Suppression, AKS, Analog-for-the-Digital Age, Any Capacitor, AnyIn, AnyOut, Augmented Switching, BlueSky, BodyCom, CodeGuard, CryptoAuthentication, CryptoAutomotive, CryptoCompanion, CryptoController, dsPICDEM, dsPICDEM.net, Dynamic Average Matching, DAM, ECAN, Espresso T1S, EtherGREEN, GridTime, IdealBridge, In-Circuit Serial Programming, ICSP, INICnet, Intelligent Paralleling, Inter-Chip Connectivity, JitterBlocker, Knob-on-Display, maxCrypto, maxView, memBrain, Mindi, MiWi, MPASM, MPF, MPLAB Certified logo, MPLIB, MPLINK, MultiTRAK, NetDetach, NVM Express, NVMe, Omniscient Code Generation, PICDEM, PICDEM.net, PICkit, PICtail, PowerSmart, PureSilicon, QMatrix, REAL ICE, Ripple Blocker, RTAX, RTG4, SAM-ICE, Serial Quad I/O, simpleMAP, SimpliPHY, SmartBuffer, SmartHLS, SMART-I.S., storClad, SQT, SuperSwitcher, SuperSwitcher II, Switchtec, SynchroPHY, Total Endurance, TSHARC, USBCheck, VariSense, VectorBlox, VeriPHY, ViewSpan, WiperLock, XpressConnect, and ZENA are trademarks of Microchip Technology Incorporated in the U.S.A. and other countries.

SQTP is a service mark of Microchip Technology Incorporated in the U.S.A.

The Adaptec logo, Frequency on Demand, Silicon Storage Technology, Symmcom, and Trusted Time are registered trademarks of Microchip Technology Inc. in other countries.

GestIC is a registered trademark of Microchip Technology Germany II GmbH & Co. KG, a subsidiary of Microchip Technology Inc., in other countries.

All other trademarks mentioned herein are property of their respective companies.

© 2021, Microchip Technology Incorporated and its subsidiaries.

All Rights Reserved.

ISBN: 978-1-5224-8966-5



# MICROCHIP

## Worldwide Sales and Service

### AMERICAS

**Corporate Office**  
2355 West Chandler Blvd.  
Chandler, AZ 85224-6199  
Tel: 480-792-7200  
Fax: 480-792-7277  
Technical Support:  
[http://www.microchip.com/  
support](http://www.microchip.com/support)  
Web Address:  
[www.microchip.com](http://www.microchip.com)

#### Atlanta

Duluth, GA  
Tel: 678-957-9614  
Fax: 678-957-1455

#### Austin, TX

Tel: 512-257-3370

#### Boston

Westborough, MA  
Tel: 774-760-0087  
Fax: 774-760-0088

#### Chicago

Itasca, IL  
Tel: 630-285-0071  
Fax: 630-285-0075

#### Dallas

Addison, TX  
Tel: 972-818-7423  
Fax: 972-818-2924

#### Detroit

Novi, MI  
Tel: 248-848-4000

#### Houston, TX

Tel: 281-894-5983

#### Indianapolis

Noblesville, IN  
Tel: 317-773-8323  
Fax: 317-773-5453  
Tel: 317-536-2380

#### Los Angeles

Mission Viejo, CA  
Tel: 949-462-9523  
Fax: 949-462-9608  
Tel: 951-273-7800

#### Raleigh, NC

Tel: 919-844-7510

#### New York, NY

Tel: 631-435-6000

#### San Jose, CA

Tel: 408-735-9110  
Tel: 408-436-4270

#### Canada - Toronto

Tel: 905-695-1980  
Fax: 905-695-2078

### ASIA/PACIFIC

**Australia - Sydney**  
Tel: 61-2-9868-6733

**China - Beijing**  
Tel: 86-10-8569-7000

**China - Chengdu**  
Tel: 86-28-8665-5511

**China - Chongqing**  
Tel: 86-23-8980-9588

**China - Dongguan**  
Tel: 86-769-8702-9880

**China - Guangzhou**  
Tel: 86-20-8755-8029

**China - Hangzhou**  
Tel: 86-571-8792-8115

**China - Hong Kong SAR**  
Tel: 852-2943-5100

**China - Nanjing**  
Tel: 86-25-8473-2460

**China - Qingdao**  
Tel: 86-532-8502-7355

**China - Shanghai**  
Tel: 86-21-3326-8000

**China - Shenyang**  
Tel: 86-24-2334-2829

**China - Shenzhen**  
Tel: 86-755-8864-2200

**China - Suzhou**  
Tel: 86-186-6233-1526

**China - Wuhan**  
Tel: 86-27-5980-5300

**China - Xian**  
Tel: 86-29-8833-7252

**China - Xiamen**  
Tel: 86-592-2388138

**China - Zhuhai**  
Tel: 86-756-3210040

### ASIA/PACIFIC

**India - Bangalore**  
Tel: 91-80-3090-4444

**India - New Delhi**  
Tel: 91-11-4160-8631

**India - Pune**  
Tel: 91-20-4121-0141

**Japan - Osaka**  
Tel: 81-6-6152-7160

**Japan - Tokyo**  
Tel: 81-3-6880-3770

**Korea - Daegu**  
Tel: 82-53-744-4301

**Korea - Seoul**  
Tel: 82-2-554-7200

**Malaysia - Kuala Lumpur**  
Tel: 60-3-7651-7906

**Malaysia - Penang**  
Tel: 60-4-227-8870

**Philippines - Manila**  
Tel: 63-2-634-9065

**Singapore**  
Tel: 65-6334-8870

**Taiwan - Hsin Chu**  
Tel: 886-3-577-8366

**Taiwan - Kaohsiung**  
Tel: 886-7-213-7830

**Taiwan - Taipei**  
Tel: 886-2-2508-8600

**Thailand - Bangkok**  
Tel: 66-2-694-1351

**Vietnam - Ho Chi Minh**  
Tel: 84-28-5448-2100

### EUROPE

**Austria - Wels**  
Tel: 43-7242-2244-39  
Fax: 43-7242-2244-393

**Denmark - Copenhagen**  
Tel: 45-4485-5910  
Fax: 45-4485-2829

**Finland - Espoo**  
Tel: 358-9-4520-820

**France - Paris**  
Tel: 33-1-69-53-63-20  
Fax: 33-1-69-30-90-79

**Germany - Garching**  
Tel: 49-8931-9700

**Germany - Haan**  
Tel: 49-2129-3766400

**Germany - Heilbronn**  
Tel: 49-7131-72400

**Germany - Karlsruhe**  
Tel: 49-721-625370

**Germany - Munich**  
Tel: 49-89-627-144-0  
Fax: 49-89-627-144-44

**Germany - Rosenheim**  
Tel: 49-8031-354-560

**Israel - Ra'anana**  
Tel: 972-9-744-7705

**Italy - Milan**  
Tel: 39-0331-742611  
Fax: 39-0331-466781

**Italy - Padova**  
Tel: 39-049-7625286

**Netherlands - Drunen**  
Tel: 31-416-690399  
Fax: 31-416-690340

**Norway - Trondheim**  
Tel: 47-7288-4388

**Poland - Warsaw**  
Tel: 48-22-3325737

**Romania - Bucharest**  
Tel: 40-21-407-87-50

**Spain - Madrid**  
Tel: 34-91-708-08-90  
Fax: 34-91-708-08-91

**Sweden - Gothenberg**  
Tel: 46-31-704-60-40

**Sweden - Stockholm**  
Tel: 46-8-5090-4654

**UK - Wokingham**  
Tel: 44-118-921-5800  
Fax: 44-118-921-5820